

DHT 1520-2 SERIES

FLANGED DUCT COILS

Specification Sheet

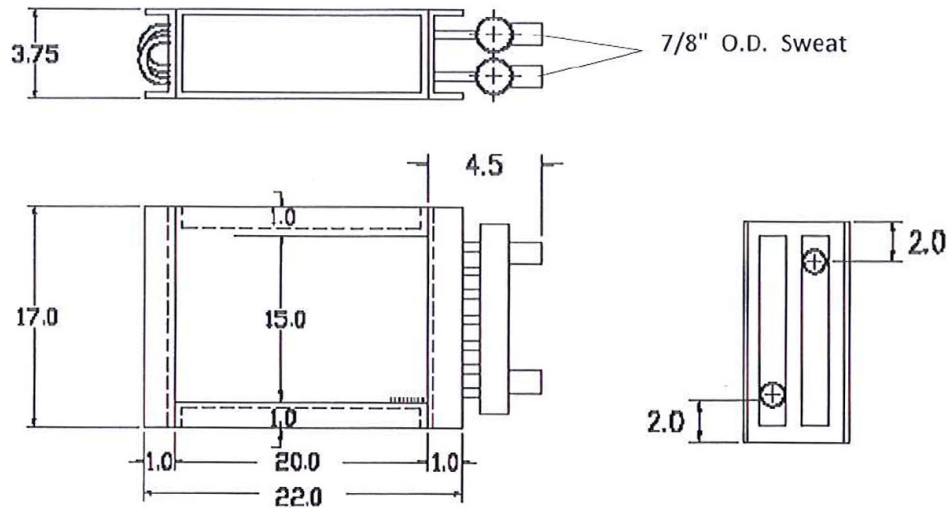

Model: DHT-1520-2				60 °F Entering Air		
E.W.T.	GPM	P.D. FT	CFM	MBTUH	L.A.T. °F	L.W.T. °F
180 °F	4	1.4	900	48.8	110	155
			1150	54.8	104	151.9
			1400	59.8	99.4	149.4
	8	5.5	900	54.2	115.6	166.1
			1150	61.8	109.6	164.1
			1400	68.3	105	162.5
	12	12.24	900	56.3	177.7	170.3
			1150	64.7	111.9	168.9
			1400	71.8	107.3	167.7

Diversified Heat Transfer, Inc.
439 Main Road, Rte. 202
Towaco, NJ 07082

CONTACT US
P. 718-386-6666 / 800-221-1522
F. 718-386-7809
E. dht@dhtnet.com

FOLLOW US @
facebook.com/diversifiedheattransfer
twitter.com/DiversifiedHeat
linkedin.com/diversified-heat-transfer

Scan Here

