

# DHT 1520-3 SERIES

## FLANGED DUCT COILS

### Specification Sheet

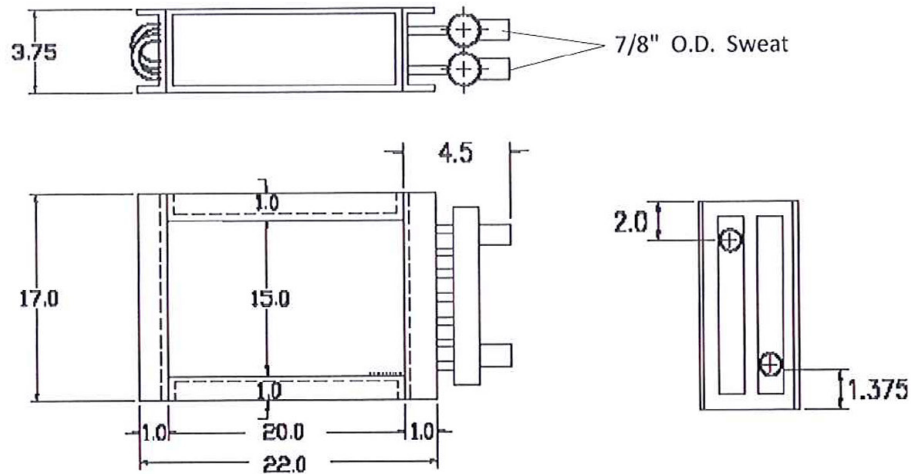

Model: DHT-1520-3				60 °F Entering Air		
E.W.T.	GPM	P.D. FT	CFM	MBTUH	L.A.T. °F	L.W.T. °F
180 °F	4	0.96	900	61.82	123.3	148.4
			1150	69.67	115.9	144.4
			1400	75.96	110	141.2
	8	3.77	900	69.21	130.9	162.2
			1150	79.68	123.9	159.6
			1400	88.47	118.3	157.3
	10	5.88	900	70.89	132.6	165.4
			1150	82.02	125.8	163.2
			1400	91.45	120.2	161.2

Diversified Heat Transfer, Inc.  
439 Main Road, Rte. 202  
Towaco, NJ 07082

CONTACT US  
P. 718-386-6666 / 800-221-1522  
F. 718-386-7809  
E. dht@dhtnet.com

FOLLOW US @  
facebook.com/diversifiedheattransfer  
twitter.com/DiversifiedHeat  
linkedin.com/diversified-heat-transfer

Scan Here

