

DHT 2030-3 SERIES

FLANGED DUCT COILS

Specification Sheet

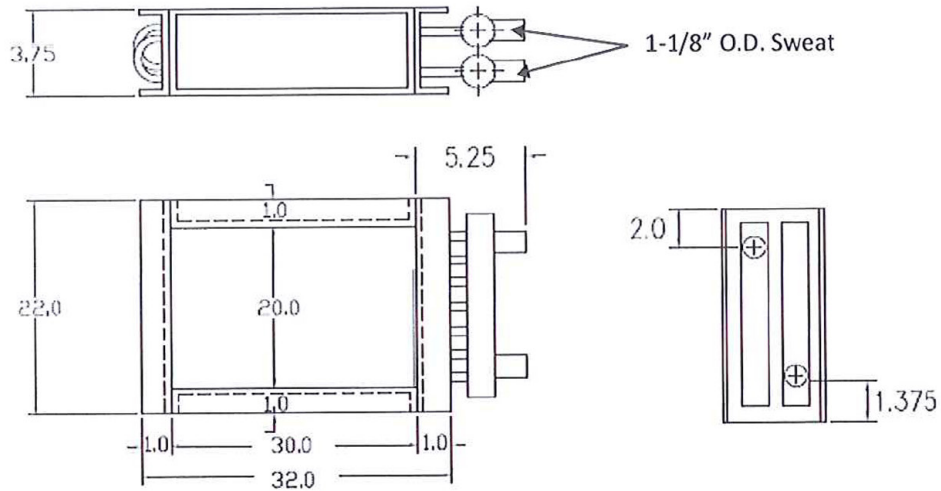

Model: DHT-2030-3				60 °F Entering Air		
E.W.T.	GPM	P.D. FT	CFM	MBTUH	L.A.T. °F	L.W.T. °F
180 °F	15	5.96	1800	140.39	131.9	160.8
			2400	165.88	123.7	157.3
			3000	186.73	117.4	154.5
	20	10.5	1800	144.3	133.9	165.2
			2400	171.7	126	162.4
			3000	194.43	119.8	160.1
	25	16.3	1800	146.74	135.2	167.9
			2400	175.38	127.4	165.6
			3000	199.35	121.3	163.6

