

**SINGLE UNIT INSTALLATION**

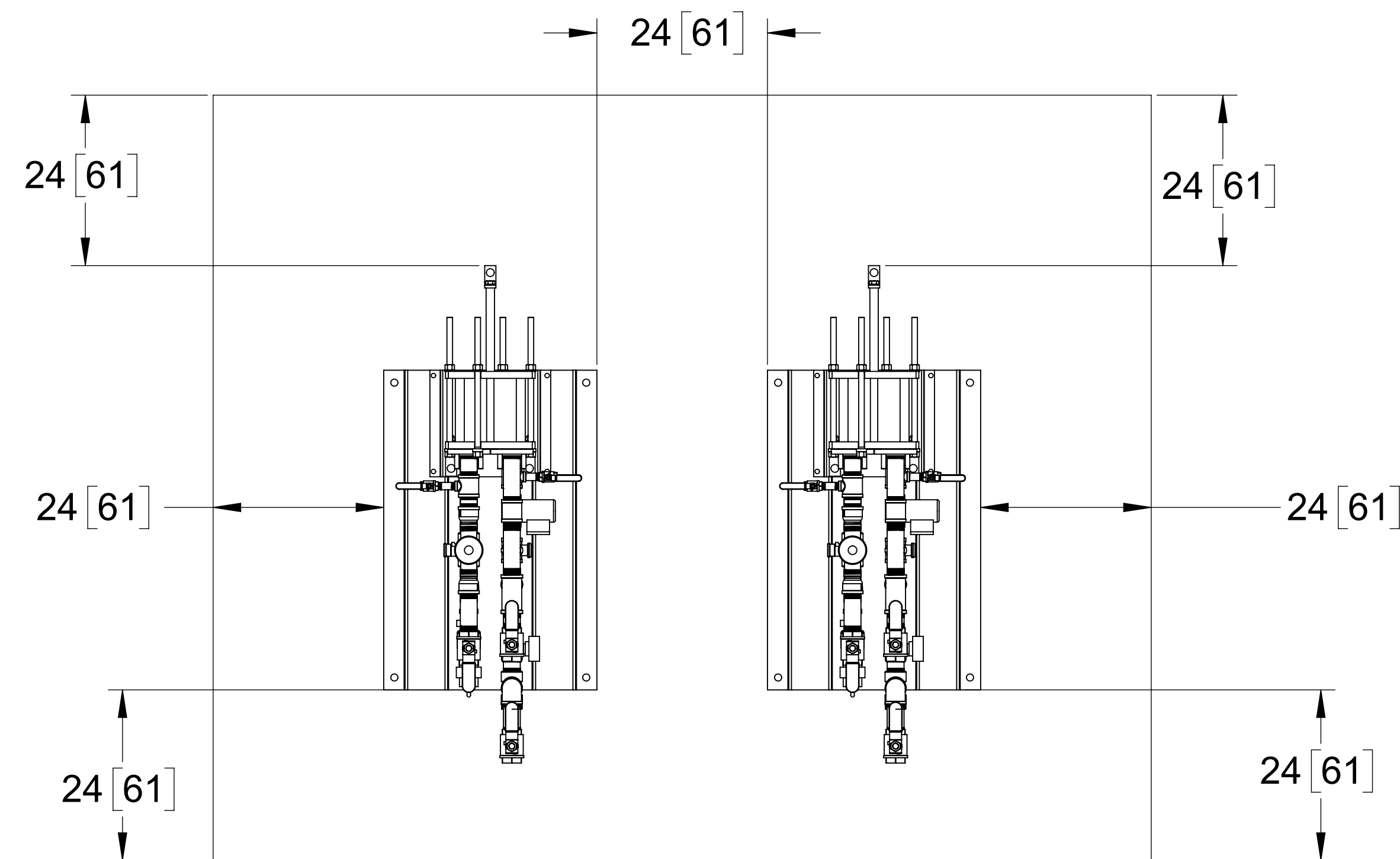

**MULTIPLE UNIT INSTALLATION**

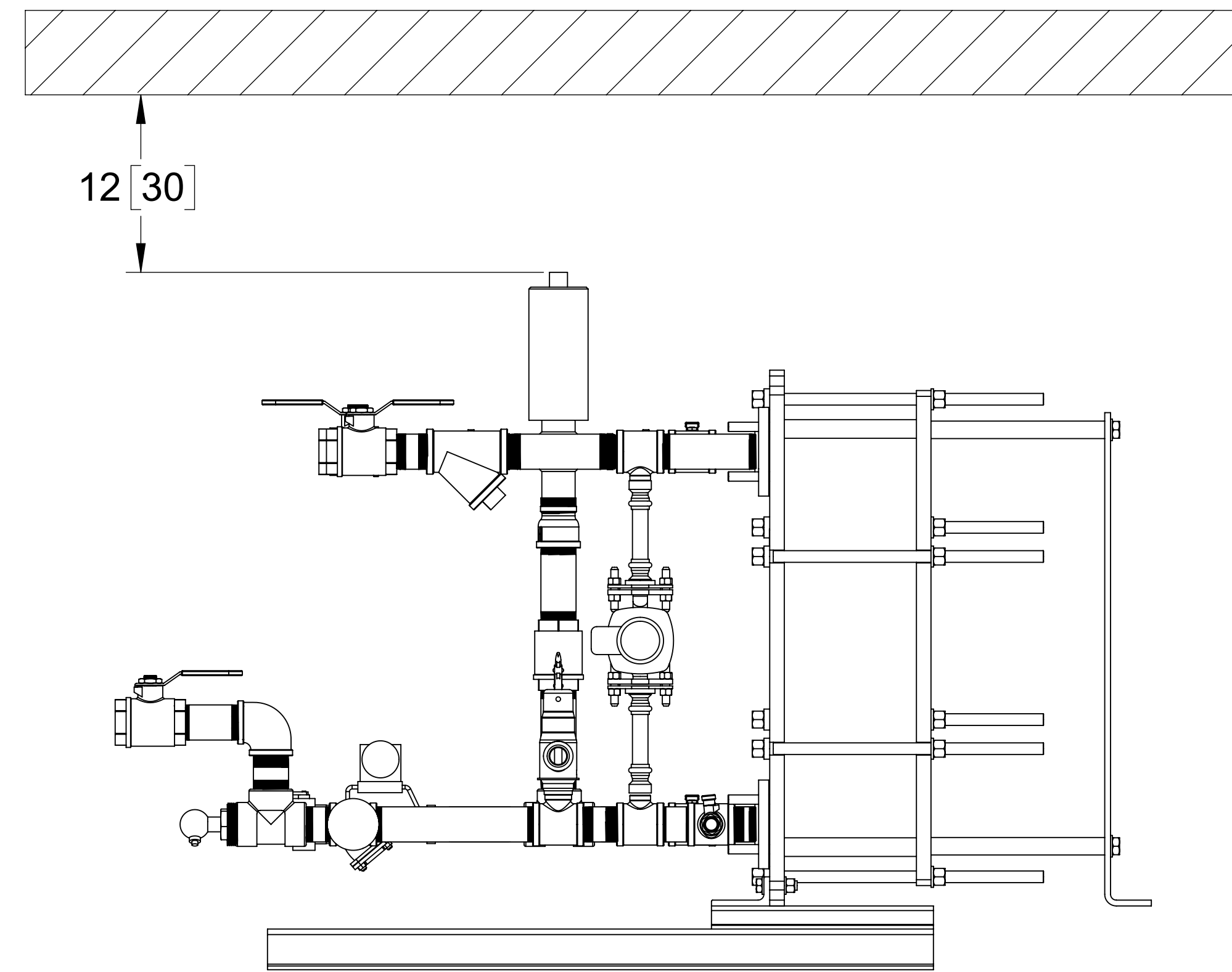

**ELEVATION VIEW**

**NOTES:**

1. ALL DIMENSIONS ARE IN INCHES [CENTIMETERS]
2. THIS DRAWING SHOWS MINIMUM RECOMMENDED SERVICE CLEARANCE DIMENSIONS AROUND THE UNIT. LOCAL CODES AND AUTHORITIES SHOULD ALSO BE CONSULTED.
3. REFER TO WATER HEATER DIMENSIONAL DRAWING TO REVIEW OTHER DIMENSIONS.
4. DHT RESERVES THE RIGHT TO MODIFY THE DIMENSIONS WITHOUT PRIOR NOTICE.
5. \* CLEARANCE DIMENSION DEPENDING UPON UNIT MODEL.

	NAME	DATE
DRAWN	HH	08/21/17
CHECKED	SS	08/24/17
ENG APPR.		
MFG APPR.		
Q.A.		
COMMENTS:		



439 MAIN ROAD, TOWACO NJ 07082

PHONE: (800) 221-1522 FAX: (855) 221-2400

**INSTALLATION CLEARANCE DRAWING**

**MODEL: SUPERPLATE WATER HEATER**

**WATER TO WATER**

DWG.#

S-11

REV

A