

| MODEL NO. | ' ϕ_1 ' NPT | 'A' | 'B' | 'C' | 'D' | 'E' |
|-----------|------------------|------|------|------|------|------|
| SPP-18D | 1-1/2" | 48.4 | 51.9 | 51.3 | 47.8 | 5.8 |
| SPP-26D | 1-1/2" | 48.4 | 51.9 | 51.3 | 47.8 | 5.8 |
| SPP-36D | 2" | 48.9 | 52.5 | 52.6 | 48.4 | 5.8 |
| SPP-52D | 2" | 48.9 | 52.5 | 52.6 | 48.4 | 5.8 |
| SPP-80D | 2" | 48.9 | 52.5 | 52.6 | 48.4 | 13.6 |
| SPP-80D | 2-1/2" | 46.3 | 55.9 | 55.7 | 49.6 | 13.6 |

| RELIEF VALVE CAPACITY | ' ϕ_2 ' NPT |
|-----------------------|------------------|
| 1,438 MBH @ 150 PSI | 3/4" |
| 3,085 MBH @ 150 PSI | 1" |
| 4,059 MBH @ 150 PSI | 1" |

* LARGER CAPACITIES REQUIRE TWO RELIEF VALVES

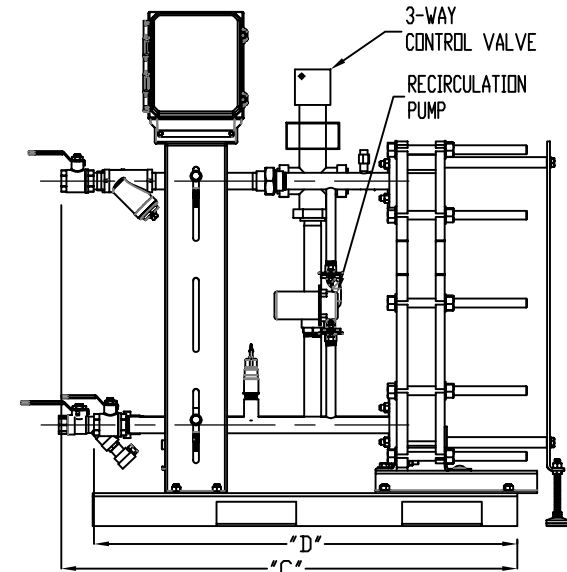
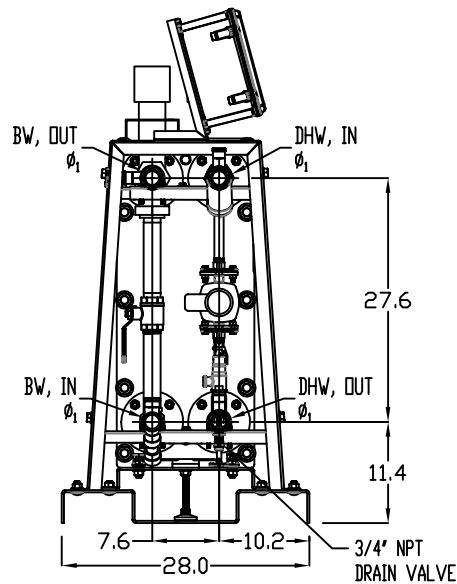
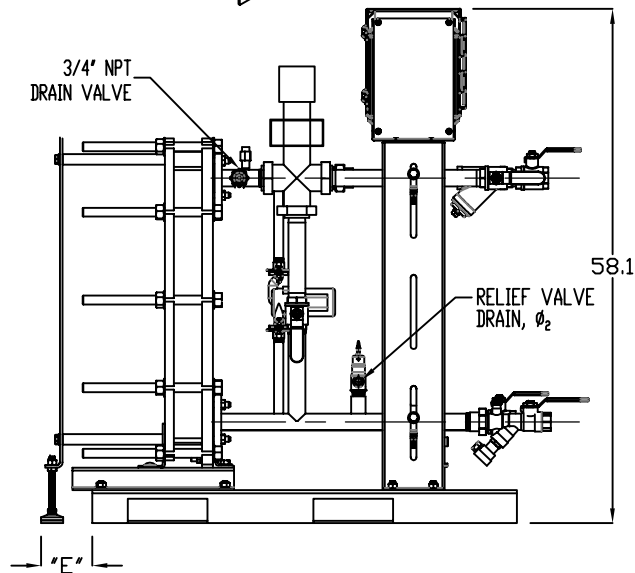

- NOTES:**
1. ALL DIMENSIONS ARE SHOWN IN INCHES.
 2. DHT RESERVES THE RIGHT TO MODIFY DIMENSIONS WITHOUT PRIOR NOTICE.
 3. DO NOT COMPLETE FIELD PIPING UNTIL UNIT IS PROPERLY INSTALLED. ACTUAL DIMENSIONS MAY VARY DUE TO MANUFACTURING TOLERANCES. FABRICATION ACCEPTS NO LIABILITY DUE TO DIMENSIONAL VARIATION.
 4. RELIEF VALVE AND DRAIN VALVES PIPED TO DRAIN BY CONTRACTOR.
 5. REFER TO INSTALLATION AND PIPING DRAWINGS FOR MORE DETAILS.
 6. ADDITIONAL REDUCER/INCREASER MAY BE REQUIRED TO MATCH CONNECTION SIZES.
 7. T&P RELIEF VALVE DIMENSIONS ARE REFERENCE ONLY AND VARIES WITH RESPECT TO THE SELECTION FOR HEATING CAPACITY.



439 MAIN RD. TOWACO NJ 07082

PHONE: (800) 221-1522

FAX: (855) 221-2400

SP SERIES
 PLATE AND FRAME DOUBLE WALL HEAT EXCHANGER
 DIMENSIONAL DRAWING

| | NAME | DATE | DWG.# | REV |
|------------|------|------------|-------|-----|
| DRAWN BY | SS | 07/12/2018 | | |
| CHECKED BY | PR | 08/03/2018 | S-28 | C |