

DHT 1724-2 SERIES

FLANGED DUCT COILS

Specification Sheet

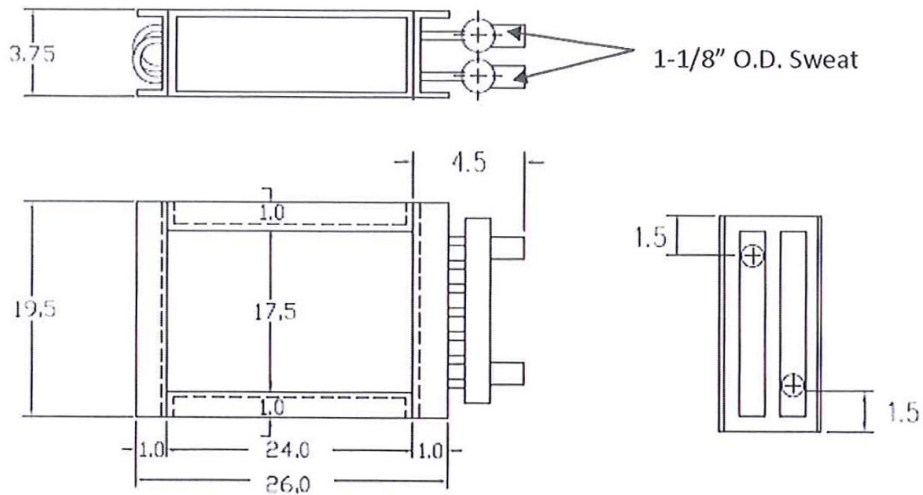

Model: DHT-1724-2				60 °F Entering Air		
E.W.T.	GPM	P.D. FT	CFM	MBTUH	L.A.T. °F	L.W.T. °F
180 °F	7	2.33	1500	78.8	108.6	157
			1700	83.5	105.4	155.6
			1900	87.8	102.7	154.3
	9	3.81	1500	82.6	110.9	161.2
			1700	87.8	107.7	160
			1900	92.5	105	158.9
	11	5.64	1500	85.2	112.5	164.1
			1700	90.8	109.4	163.1
			1900	95.9	106.6	162.1

