

DHT 2030-2 SERIES

FLANGED DUCT COILS

Specification Sheet

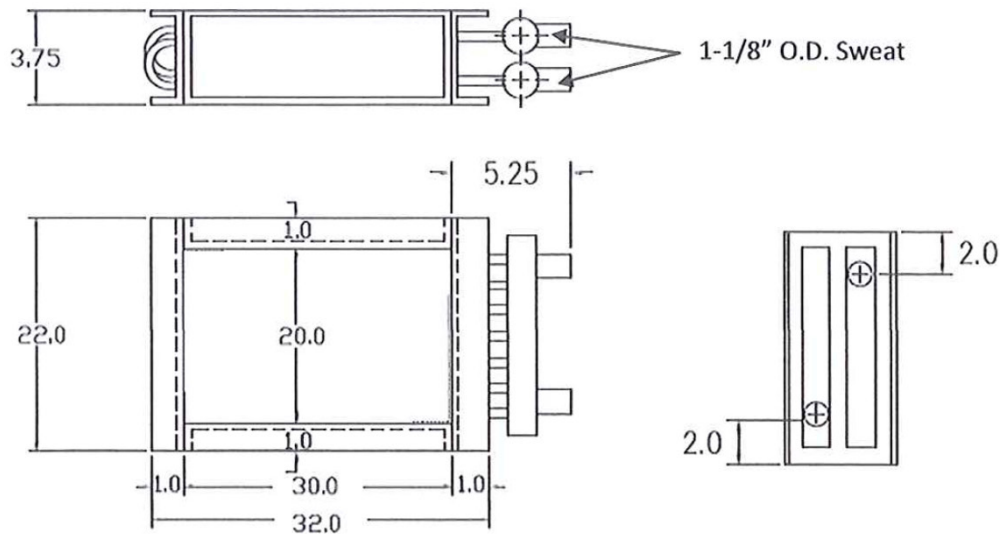

Model: DHT-2030-2				60 °F Entering Air		
E.W.T.	GPM	P.D. FT	CFM	MBTUH	L.A.T. °F	L.W.T. °F
180 °F	15	4.98	1800	107.64	115.1	165.3
			2400	125.38	108.2	162.8
			3000	139.87	103	160.9
	20	8.8	1800	110.96	116.8	168.6
			2400	129.97	109.9	166.7
			3000	145.65	104.8	165
	25	13.68	1800	113	117.9	170.7
			2400	132.92	111.1	169.1
			3000	149.4	105.9	167.7

