

# DHT 2525-2 SERIES

## FLANGED DUCT COILS

### Specification Sheet

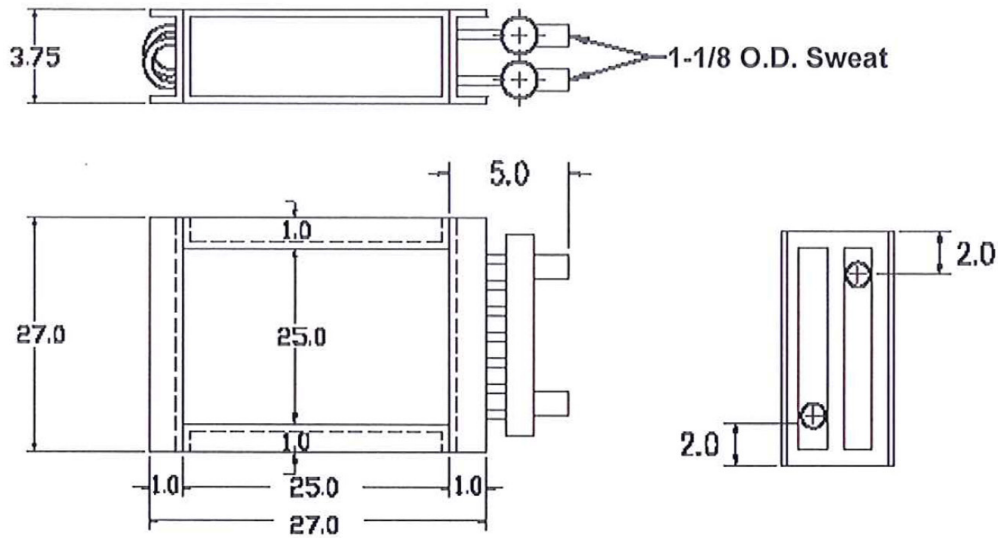

Model: DHT-2525-2				60 °F Entering Air		
E.W.T.	GPM	P.D. FT	CFM	MBTUH	L.A.T. °F	L.W.T. °F
180 °F	9.8	3.8	1800	101.1	111.8	158.8
			2400	116.4	104.7	155.6
			3000	128.6	99.5	153.1
	11.2	4.96	1800	103.5	113	161
			2400	119.5	105.9	158.1
			3000	132.4	100.7	155.8
	12.5	6.17	1800	105.2	133.9	162.7
			2400	121.9	106.9	160
			3000	135.4	101.6	157.8

