

4

3

2

1

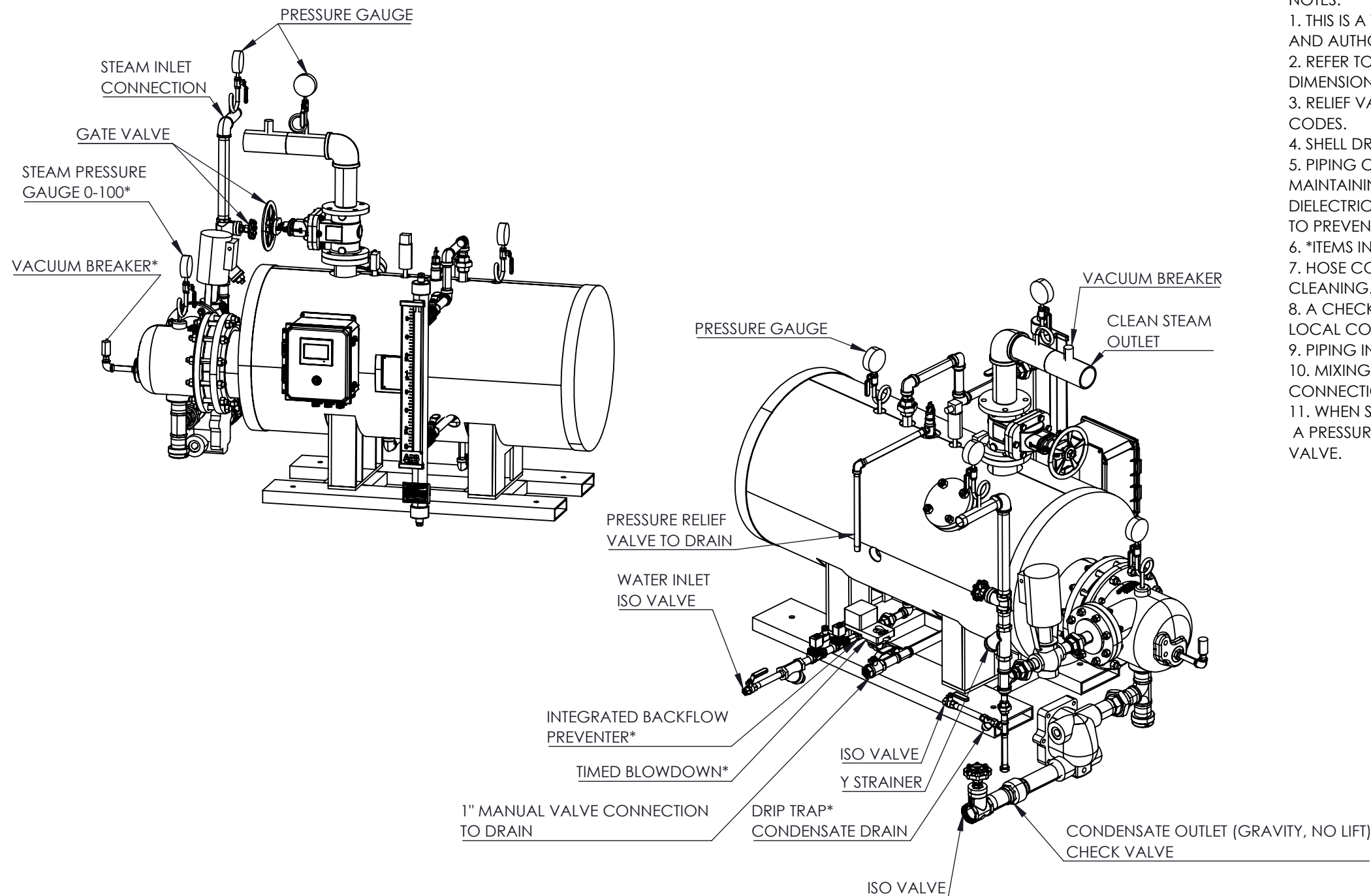

- NOTES:
1. THIS IS A TYPICAL SINGLE UNIT INSTALLATION PIPING DRAWING. CONSULT LOCAL CODES AND AUTHORITIES.
 2. REFER TO APPROPRIATE DIMENSIONAL DRAWING OF UNIT FOR ACTUAL SIZE AND LOCATION DIMENSIONS OF PIPING AND OTHER CONNECTIONS.
 3. RELIEF VALVE SHALL BE INSTALLED TO SAFE DRAIN ACCORDING TO APPROPRIATE PLUMBING CODES.
 4. SHELL DRAIN AND CONDENSATE SHALL DRAIN FREELY BY GRAVITY.
 5. PIPING CONNECTIONS TO THE UNIT SHALL BE PROVIDED WITH UNIONS OR FLANGES MAINTAINING ENOUGH CLEARANCES FOR SERVICE. DIELECTRIC FITTINGS ARE SUGGESTED TO MAKE CONNECTIONS BETWEEN DISSIMILAR METALS TO PREVENT GALVANIC CORROSION.
 6. *ITEMS INCLUDED IN SHIPMENT WITH UNIT FOR FIELD INSTALLATION.
 7. HOSE CONNECTION ON THE UNIT OUTLET IS UTILIZED DURING STARTUP CALIBRATION AND CLEANING.
 8. A CHECK VALVE MAY BE UTILIZED IN PLACE OF BACKFLOW PREVENTER IF PERMITTED BY LOCAL CODES.
 9. PIPING INSTALLATION COMPONENTS ARE SUPPLIED BY OTHERS IN THE FIELD.
 10. MIXING VALVE SHOULD NOT BE INSTALLED WITHIN 20 FEET OF WATER HEATER OUTLET CONNECTION.
 11. WHEN STEAM INLET PRESSURE IS HIGHER THAN REQUIRED, A PRESSURE REGULATING VALVE SHALL BE PROVIDED BEFORE STEAM INLET TO CONTROL VALVE.

DIMENSIONS ARE SHOWN IN INCHES (CENTIMETERS)
 TOLERANCES ARE AS FOLLOWS UNLESS OTHERWISE SPECIFIED
 X.XX X.XXX X.XXXX ANGULAR FINISH
 ±.12 ±.031 ±.0156 ±1.0° 250
 REMOVE AND DEBURR SHARP EDGES AND CORNERS
 ALL DIMENSIONS ARE AFTER FINISH OR PLATING
 REFERENCE DIMENSIONS ARE SHOWN IN PARENTHESES ()
 CRITICAL DIMENSIONS ARE SHOWN IN ◻



PHONE: (800) 221-1522 FAX: (718) 386-7809

THIS DRAWING AND/OR SPECIFICATIONS ARE THE PROPERTY OF DIVERSIFIED HEAT TRANSFER INC. THIS CONFIDENTIAL AND PROPRIETARY INFORMATION SHALL NOT BE USED, COPIED OR REPRODUCED IN ANY MEANS AS THE BASIS FOR MANUFACTURE OR SALE OF APPARATUS WITHOUT WRITTEN AUTHORIZATION FROM OWNER.

TITLE
 SUPERSTEAM HORIZONTAL - PIPING & INSTALLATION

REV.	ECO.	REVISION DESCRIPTION	NAME	DATE

THIRD ANGLE PROJECTION	DWG. SCALE	MATERIAL SPEC:
	1:50	

DRAWN BY	NAME	DATE	DWG#	REV
CHECKED BY	BS	7/8/22	SSH-P	A/1
			SHEET 1 OF 1	

4

3

2

1