

4

3

2

1

NOTES:

- 1. ALL DIMENSIONS ARE IN INCHES [MM]
- 2. SPACE NECCESARY FOR TUBE BUNDLE REMOVAL WILL BE DETERMINED BY BUNDLE LENGTH
- 3. THIS DRAWING SHOWS MINIMUM RECOMENDED SERVICE CLEARANCE DIMENSIONS
- 4. REFER TO THE SP DIMENSIONAL DRAWING FOR FULL UNIT DIMENSIONS
- 5. DHT RESERVES THE RIGHT TO MODIFY THE DIMENSONS WITHOUT PRIOR NOTICE
- 6. CONSULT LOCAL CODES AND AUTHORITIES BEFORE INSTALL.

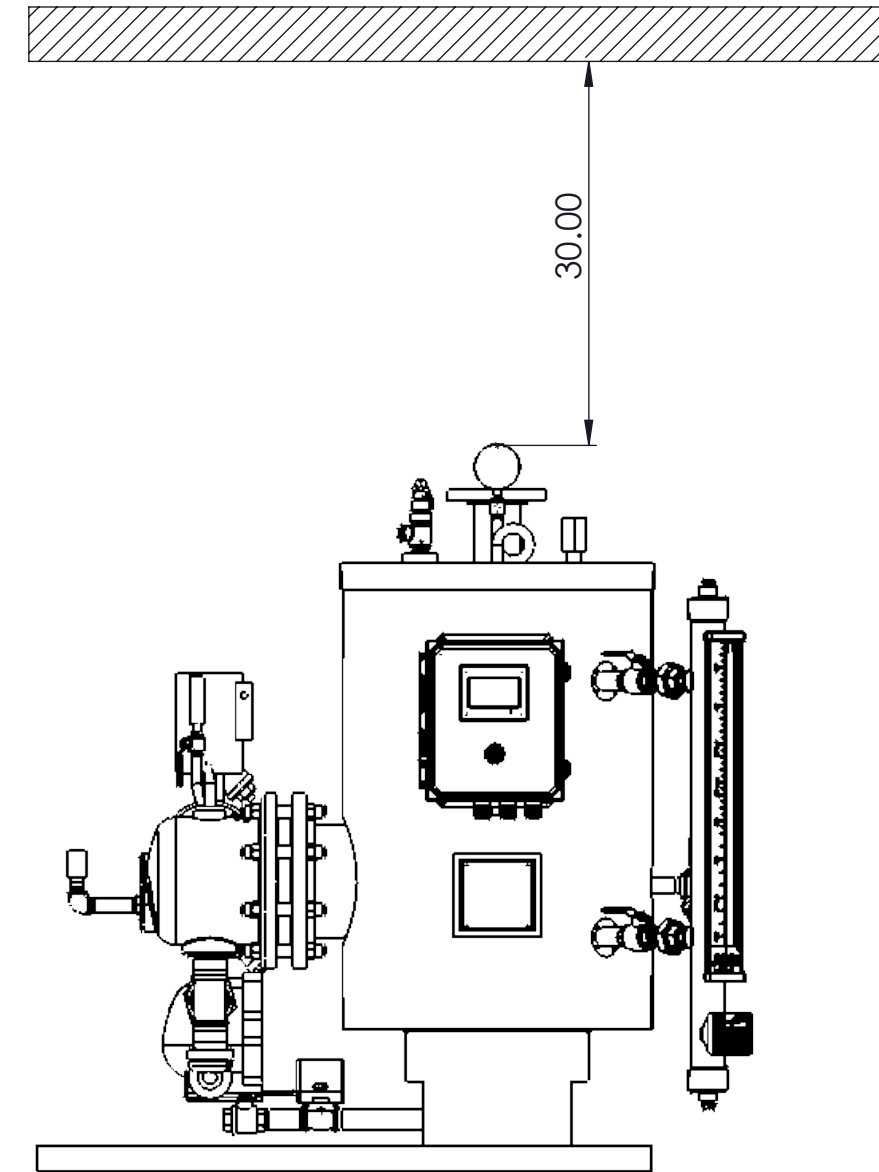
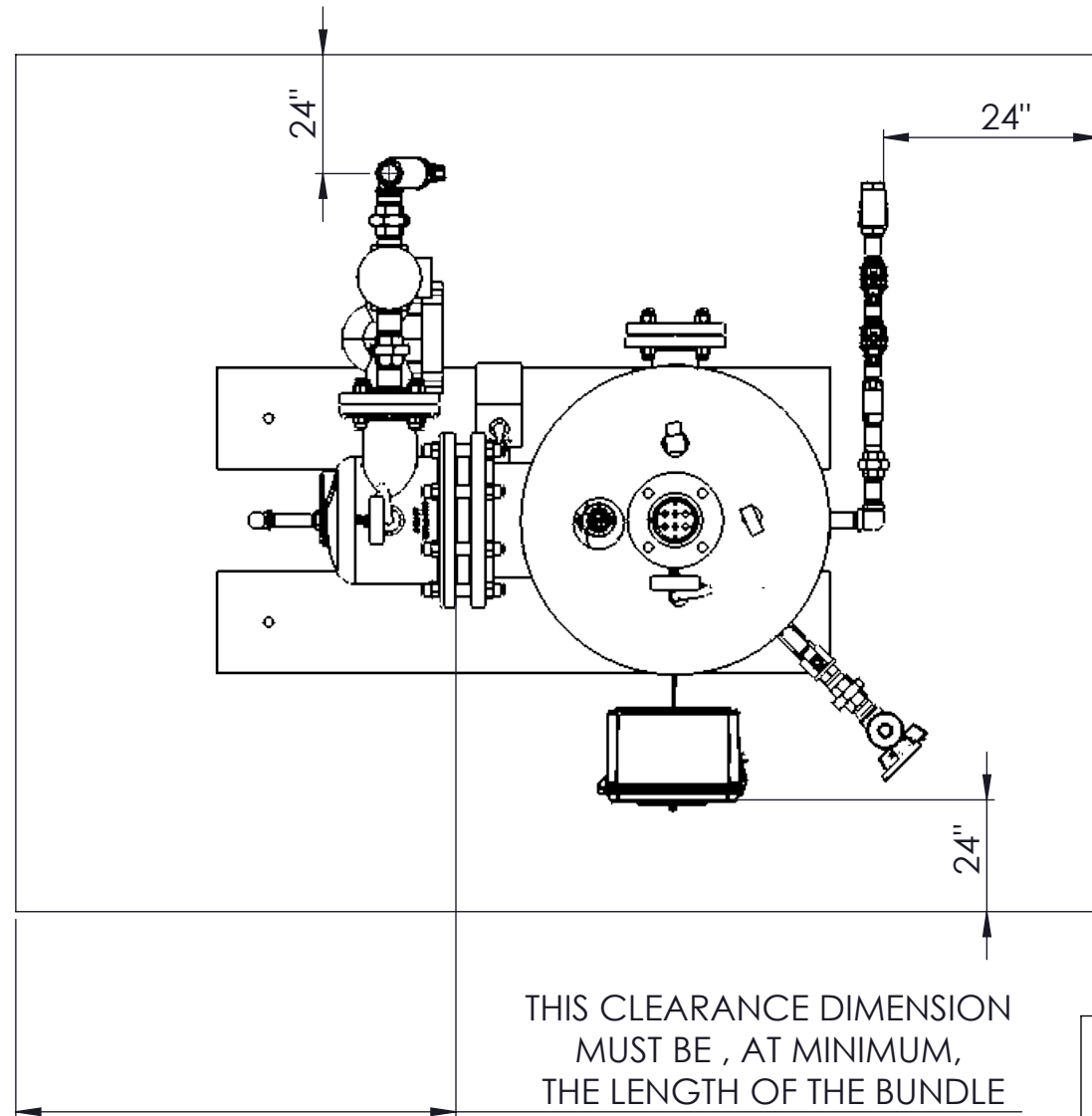

DIMENSIONS ARE SHOWN IN INCHES [CENTIMETERS]
 TOLERANCES ARE AS FOLLOWS UNLESS OTHERWISE SPECIFIED
 X.XX X.XXX X.XXXX ANGULAR FINISH
 ±.12 ±.031 ±.0156 ±1.0° 250

REMOVE AND DEBURR SHARP EDGES AND CORNERS
 ALL DIMENSIONS ARE AFTER FINISH OR PLATING
 REFERENCE DIMENSIONS ARE SHOWN IN PARENTHESES ()
 CRITICAL DIMENSIONS ARE SHOWN IN

THIS DRAWING AND/OR SPECIFICATIONS ARE THE PROPERTY OF DIVERSIFIED HEAT TRANSFER INC. THIS CONFIDENTIAL AND PROPRIETARY INFORMATION SHALL NOT BE USED, COPIED OR REPRODUCED IN ANY MEANS AS THE BASIS FOR MANUFACTURE OR SALE OF APPARATUS WITHOUT WRITTEN AUTHORIZATION FROM OWNER.



439 MAIN RD. TOWACO NJ 07082
 PHONE: (800) 221-1522 FAX: (718) 386-7809

TITLE
 SUPER STEAM
 CLEARANCE DRAWING

REV.	ECO.	REVISION DESCRIPTION	NAME	DATE

THIRD ANGLE PROJECTION 	DWG. SCALE 1:20	MATERIAL SPEC:	NAME JC	DATE 6/9/2022	DWG# .	REV 1
			CHECKED BY		SHEET 1 OF 1	

4

3

2

1