

AHCC SERIES- CASED HYDRONIC HEATING

Model: AHCC-3-210

The AHCC Series Cased Hydronic Heating Units are designed to provide exceptional hydronic heating when matched with any residential air handling system and a hot water source. The unit may be mounted upflow, counter flow or horizontally on the supply end of the air handler or within the duct system. The coils are designed and tested in accordance with the current AHRI Standard 410 and manufactured with UL listed components.

- High Performance Aluminum Fins
- Galvanized Casing with Access Panel
- Simple Installation in Multiple Configurations

Available through our large network of wholesale distributors.

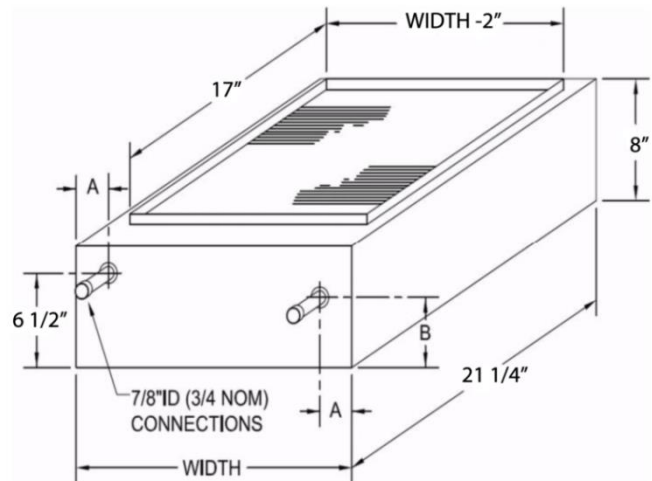

| 3 Row Unit | | | |
|------------|-------|----|----------|
| Model | Width | A | B |
| AHCC-3-210 | 21" | 2" | 4-11/32" |

| Model Number: AHCC-3-210 | | | | | | | | | |
|--------------------------|------------------|------------------|--------------------|---------------------|------------|---------------------|---------------------|--------------------|---------------------|
| Total CFM | Ent. Dry Bulb °F | Lvg. Dry Bulb °F | Total Capacity MBH | Air Press. Drop "WG | Fluid Type | Total Flow Rate GPM | Ent. Fluid Temp. °F | Lvg. Fluid Temp °F | Fld Press. Drop 'WG |
| 800 | 65.0 | 130.58 | 60.4 | 0.14 | Water | 7.8 | 160 | 144.98 | 9.63 |
| 900 | 65.0 | 128.79 | 66.0 | 0.15 | Water | 8.4 | 160 | 144.74 | 10.32 |
| 1000 | 65.0 | 127.17 | 71.5 | 0.16 | Water | 9.0 | 160 | 144.58 | 11.71 |
| 1100 | 65.0 | 125.69 | 76.7 | 0.18 | Water | 9.6 | 160 | 144.48 | 13.19 |
| 1200 | 65.0 | 124.18 | 81.5 | 0.21 | Water | 10.0 | 160 | 144.15 | 14.22 |
| 1300 | 65.0 | 122.93 | 86.6 | 0.25 | Water | 10.6 | 160 | 144.14 | 15.83 |
| 1400 | 65.0 | 121.70 | 91.3 | 0.27 | Water | 11.1 | 160 | 144.04 | 17.23 |
| 800 | 65.0 | 147.22 | 75.6 | 0.14 | Water | 11.1 | 180 | 166.70 | 16.83 |
| 900 | 65.0 | 142.43 | 80.1 | 0.15 | Water | 8.4 | 180 | 161.39 | 10.10 |
| 1000 | 65.0 | 140.47 | 86.7 | 0.16 | Water | 9.0 | 180 | 161.19 | 11.47 |
| 1100 | 65.0 | 138.68 | 93.2 | 0.18 | Water | 9.6 | 180 | 161.07 | 12.91 |
| 1200 | 65.0 | 136.85 | 99.1 | 0.21 | Water | 10.0 | 180 | 160.66 | 13.93 |
| 1300 | 65.0 | 135.34 | 105.1 | 0.25 | Water | 10.6 | 180 | 160.65 | 15.50 |
| 1400 | 65.0 | 133.85 | 110.9 | 0.27 | Water | 11.1 | 180 | 160.53 | 16.88 |