

D21/22 - D36 - D47 - D64 PLATE HEAT EXCHANGERS

Technical Data Sheet

Recommended Applications:

The range of DHT plate heat exchangers is specially designed for the HVAC geothermal, marine, and heat recovery area as well as the food, industrial and chemical market.

Design Principle:

The D21/22, D36, D47 and D64 plate range with lengths up to 6.2 ft (1.9 m) and a “long” thermal pattern will cover many duties up to 661 gpm (150 m³ /h) in a single pass solution, meaning that all the connections are on the head side. This will ensure easy pipe and service work, and by dismantling the exchanger for service, no pipes need to be removed.

The heat transfer is obtained, when the warm medium transfers energy through the thin, strong flow plates between the channels and delivers it to the cold opposing medium without mixing the two media. Counter-current flow creates the optimal efficiency. The plate- and inlet design allows effective, easy CIP (Cleaning in Place) of all “flow” surfaces.

Flow plates:

The corrugated “herringbone” pattern ensures turbulent flow in the whole effective area. Furthermore, this pattern brings “metallic” contact between the plates, and together with “Sonder Lock” locking devices on the gaskets, the plate pack is easily assembled. The plate pack is held firm and safely between the head and movable follower of the frame.

Data Required for Correct Quotation:

The below data determines the choice of heat exchanger

- Duty
- Flow rate
- Temperature
- Type of media
- Working pressure
- Working Temperature
- Pressure Loss
- Thermodynamic Properties



Model: D31A shown

Technical Information:

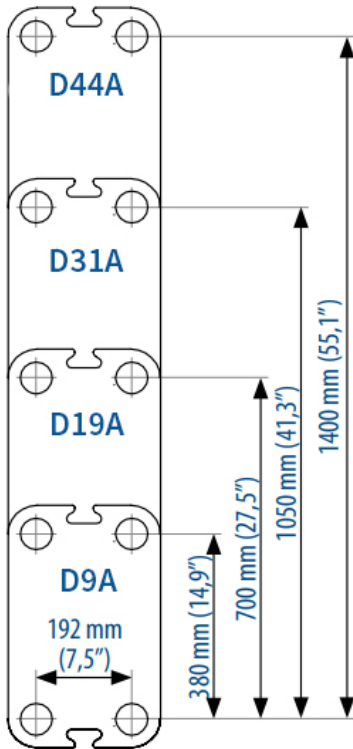

Frame:

- Painted frame, color RAL 5010 (available in other colors)
- Stainless steel frame, designed for the food and dairy industry.
- Both frames comes with clamping bolts placed around the frame edge.

Design pressure:

- Painted frames: 145/232/362 PSI (1.0/1.6/2.5 MPa)
- Stainless steel frame: 145/232 PSI (1.0/1.6 MPa)

Intermediate Frames:

Intermediate frames and corner blocks for IS and FS frames in stainless steel.

Construction Standard:

- EN13445 (PED 2014/68/EU)
- ASME sec VIII, Div. 1

Connections:

- DN100/4" flange in ca bon steel, rubberlined or clad with AISI 316 or titanium.
- DN80/3" and DN100/4" dairy unions. According to all known standards

Plate Material:

- AISI 304/316, 254 SMO and titanium.
- Also 2 x 0.4 mm "Sonder Safe" plates, for food and industry
- Other materials available on request.

Gaskets:

- The gasket is the unique non-glued "Sonder lock" gasket which locks the plates together with strong rubber buttons, so that the plates are strongly guided during the assembly of the plate heat exchanger.
- Materials: NBR, EPDM and Viton.
- Other materials available on request.

Extra Equipment:

- Safety cover in stainless steel
- Insulating jacket
- Assembling spanner
- Foundation feet
- Instrument flange
- Thermometer and manometer

DHT can accept no responsibility for possible errors in catalogs, brochures, and other printed material. DHT reserves the right to alter its products without notice. DHT and the DHT logotype are trademarks of DHT. All rights reserved.

Diversified Heat Transfer, Inc.
439 Main Road, Rte. 202
Towaco, NJ 07082

CONTACT US
P. 718-386-6666 / 800-221-1522
F. 718-386-7809
E. sales@dhtnet.com

FOLLOW US @
facebook.com/diversifiedheattransfer
twitter.com/DiversifiedHeat
linkedin.com/diversified-heat-transfer

Scan Here

