

UNIT	"A" SW/DW	"B"	"C"
6"	53.25/55"	19"	34"
8"	57.38/59.25"	24"	34"
10"	57.75/59.75"	26"	32"
12"	60.25/62.25"	27.25"	32"

VALVE ASSY	"V"
1"	11.38"
1.25"	12.38"
1.5"	13"
2"	14.25"
2.5"	16"
3"	16.88" (8" UNIT 11.75")
4"	19" (10" UNIT 13.88")
5"	19.88" (12" UNIT 15.75")

Y STRAINER ASSY	"Y1"	"Y2"
2-1.25	6.25"	10.5"
2-1.5	6.5"	10.5"
2.5-2	7.75"	10.5"
2.5-2.5	4.88"	15.75"
3-2.5	4.88"	18.75"
3-3	5.5"	17.25"
4-3	5.5"	21.5"
4-4	6.5"	20.5"
5-4	6.5"	25"
5-5	7.5"	24"

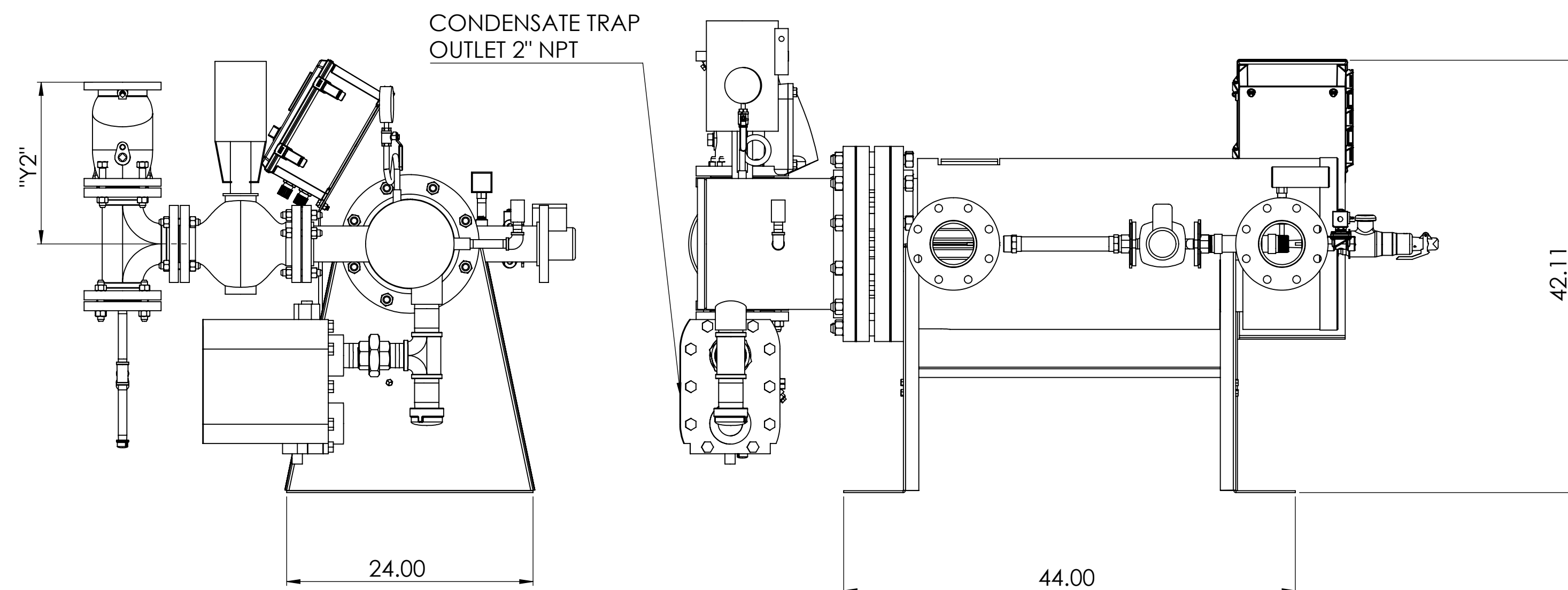

ALL DIMENSIONS ARE FOR REFERENCE
DHT RESERVES THE RIGHT TO MAKE DIMENSIONAL CHANGES WITHOUT NOTICE

DIMENSIONS ARE SHOWN IN INCHES [CENTIMETERS]
TOLERANCES ARE AS FOLLOWS UNLESS OTHERWISE SPECIFIED
X.XX X.XXX X.XXXX ANGULAR FINISH
±.12 ±.031 ±.0156 ±1.0° 250
REMOVE AND DEBURR SHARP EDGES AND CORNERS
ALL DIMENSIONS ARE AFTER FINISH OR PLATING
REFERENCE DIMENSIONS ARE SHOWN IN PARENTHESES ()
CRITICAL DIMENSIONS ARE SHOWN IN

THIS DRAWING AND/OR SPECIFICATIONS ARE THE PROPERTY OF DIVERSIFIED HEAT TRANSFER INC. THIS CONFIDENTIAL AND PROPRIETARY INFORMATION SHALL NOT BE USED, COPIED OR REPRODUCED IN ANY MEANS AS THE BASIS FOR MANUFACTURE OR SALE OF APPARATUS WITHOUT WRITTEN AUTHORIZATION FROM OWNER.



TITLE SUPER THERM HORIZONTAL MOUNT
DIMENSIONAL DRAWING

A	.	.	JC	10/28/20	THIRD ANGLE PROJECTION	DWG. SCALE	MATERIAL SPEC:	NAME	DATE	DWG#	REV
REV.	ECO.	REVISION DESCRIPTION	NAME	DATE		1:10	SEE NOTES	DRAWN BY	JAC	STH-DIM	A
								CHECKED BY	.	SHEET 1 OF 1	