

TECHNICAL DATA SHEET

DOMESTIC WATER STORAGE TANK

VERTICAL BARE TANK

FEATURES:

- Designed for storage of potable hot water up to 180 degrees F.
- Vertical or Horizontal configurations.
- 125 PSI Standard.
- 150 psi (optional), >150 psi is available upon request.
- 3/4" Aquastat NPT fittings.
- 3" NPT circulation fittings standard. Custom connection sizes optional.
- Glass Lining Standard.
- Double glass lining or Duplex Stainless Steel (optional on 175 gallon and greater).
- Manways included on tanks over 36" diameter
- Magnesium Anodes or Power Anodes (optional).
- 4" Skirt on 30" to 48" diameter, 6" Skirt on 54" diameter and above.
- Lift Lugs Standard
- Red Oxide Primer
- R-16 Topcoat optional.
- Certifications: ASME IV, Part HLW.
- Warranty:
 - Steel tank (5 years).
 - Steel tank with double glass lining (10 years)
 - Duplex steel tank (25 Years)

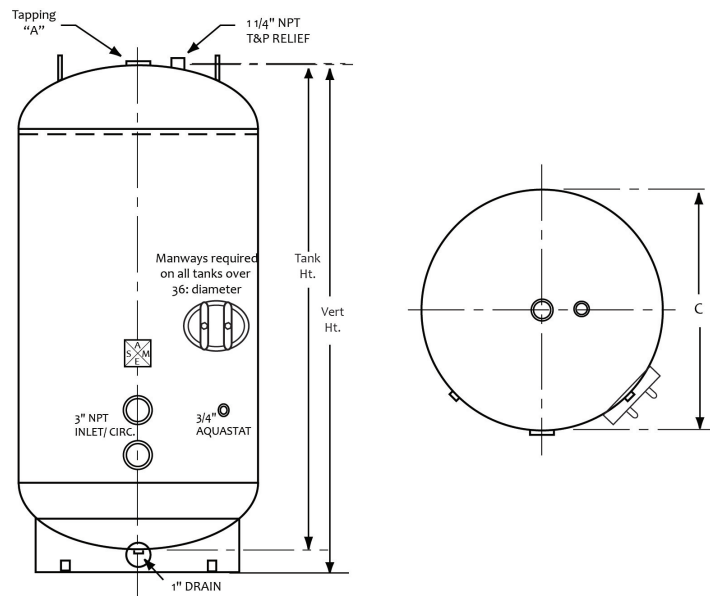

| MODEL NUMBER | ACTUAL GALLONS CAPACITY | VERTICAL HEIGHT (HT) | BASE CLEARANCE | DIAMETER | "A" HOT OUTLET | WEIGHT @125# (LBS) |
|--------------|-------------------------|----------------------|----------------|----------|----------------|--------------------|
| D-24-062 | 119 | 62" | N/A | 24" | 2" | 225 |
| D-24-062-A | 119 | 62" | N/A | 24" | 2" | 225 |
| D-30-063 | 175 | 67" | 4" | 30" | 2.50" | 340 |
| D-30-075 | 210 | 79" | 4" | 30" | 2.50" | 387 |
| D-30-085 | 240 | 89" | 4" | 30" | 2.50" | 420 |
| D-36-078 | 310 | 82" | 4" | 36" | 2.50" | 588 |
| D-42-084 | 453 | 88" | 4" | 42" | 3.00" | 805 |
| D-48-073 | 500 | 77" | 4" | 48" | 3.00" | 1038 |
| D-42-093 | 505 | 97" | 4" | 42" | 3.00" | 874 |
| D-48-108 | 765 | 112" | 4" | 48" | 3.00" | 1433 |
| D-48-141 | 1040 | 145" | 4" | 48" | 3.00" | 1805 |
| D-54-113 | 1000 | 119" | 6" | 54" | 3.00" | 1827 |

Note: Dimensions and Specifications subject to change without notice.

JACKETED AND INSULATED TANK

FEATURES:

- Designed for storage of potable hot water up to 180 degrees F.
- Vertical or Horizontal configurations.
- 125 PSI Standard.
- 150 psi (optional), >150 psi is available upon request.
- 3/4" Aquastat NPT fittings.
- 3" NPT circulation fittings standard. Custom connection sizes optional.
- Sturdy steel jacket
- Glass Lining Standard.
- Double glass lining or Duplex Stainless Steel (optional on 175 gallon and greater).
- Manways included on tanks over 36" diameter
- Magnesium Anodes or Power Anodes (optional).
- Tank is mounted on 2" fork-lift rails for easy lifting
- 2" High density foam insulation- meets ASHRAE 90.1b (2010 version) requirements
- Certifications: ASME IV, Part HLW.
- Warranty:
 - Steel tank (5 years).
 - Steel tank with double glass lining (10 years)
 - Duplex steel tank (25 Years)

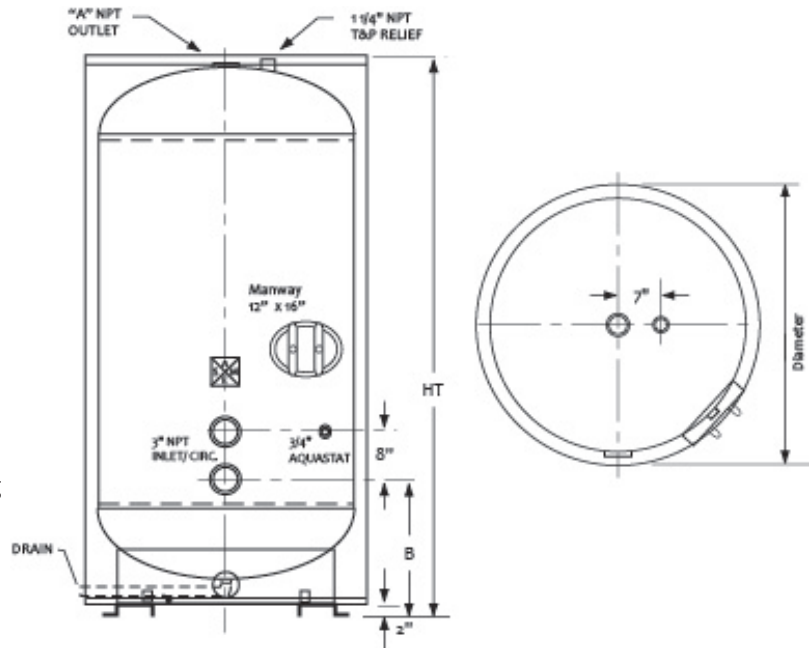

| MODEL NUMBER | ACTUAL GALLONS CAPACITY | VERTICAL HEIGHT (HT) | BASE CLEARANCE | "B" | DIAMETER | "A" HOT OUTLET | WEIGHT @125# (LBS) |
|--------------|-------------------------|----------------------|----------------|--------|----------|----------------|--------------------|
| DH-28-120 | 119 | 63.50" | N/A | 9.25" | 28" | 2" | 225 |
| DH-28-120-A | 119 | 63.50" | N/A | 9.25" | 28" | 2" | 225 |
| DH-30-063 | 175 | 71" | 2" | 19.50" | 34" | 2.50" | 548 |
| DH-30-075 | 210 | 83" | 2" | 19.50" | 34" | 2.50" | 613 |
| DH-30-085 | 240 | 93" | 2" | 19.50" | 34" | 2.50" | 673 |
| DH-36-078 | 310 | 86" | 2" | 21.00" | 40" | 2.50" | 782 |
| DH-42-084 | 453 | 92" | 2" | 22.50" | 46" | 3.00" | 1074 |
| DH-48-073 | 500 | 81" | 2" | 24.00" | 52" | 3.00" | 1381 |
| DH-42-093 | 505 | 101" | 2" | 22.50" | 46" | 3.00" | 1168 |
| DH-48-108 | 765 | 116" | 2" | 24.00" | 52" | 3.00" | 1803 |
| DH-48-141 | 1040 | 149" | 2" | 24.00" | 52" | 3.00" | 2216 |
| DH-54-113 | 1000 | 121" | 2" | 27.50" | 58" | 3.00" | 2400 |

Note: Dimensions and Specifications subject to change without notice.

DHT can accept no responsibility for possible errors in catalogs, brochures, and other printed material. DHT reserves the right to alter its products without notice. DHT and the DHT logotype are trademarks of DHT. All rights reserved.



439 Main Road, Rte. 202
Towaco, NJ 07082
www.dhtnet.com

Phone: 718-386-6666
Toll Free: 800-221-1522
Fax: 718-386-7809
Email: sales@dhtnet.com