



**SUSSMAN**  
ELECTRIC BOILERS

**ES Electric Steam Boiler  
& SSB Stainless Steel Boiler:  
EPC Controller Manual**

Sussman Electric Boilers  
439 Main Road, Towaco, New Jersey 07082  
(718) 386-6666 • 1-800-221-1522  
[sussmanboilers.com](http://sussmanboilers.com) • Email: [seb@dhtnet.com](mailto:seb@dhtnet.com)

### 1.1 General Information



#### General Description of Operator Buttons:

Temperature Controller has six buttons (four navigation and two function) available as shown in following button layout:



#### Button Operation

- **Page:** In Operator levels 1 or 2, the Page button will select between the Home display or the Programmer Edit and Run lists (if one of the programmer features is enabled). In Levels 3 or Config the Page button will scroll through list headers (no auto-repeat). If the Page button is pressed within a list, the display reverts to the top of the list. The top of the list shows only the list header with no initial parameters.
- **Page (held for >3 seconds):** The Goto parameter is selected directly. This operation can be performed from any display. If the Page is held for >3 seconds at power-up, the Quick Start Mode is selected following the entry of a passcode.
- **Page+Raise:** Scroll back the list headers (with auto-repeat).

- **Scroll:** Select parameters in turn, returning to the first parameter in the list or to a list header if Level 3 or Configuration level is selected. If the button is held down the list will auto-repeat. In levels 1 and 2 this button also scrolls through promoted parameters when the HOME screen is selected.
- **Scroll+Raise:** Scroll back through parameters from bottom to top (with auto-repeat).
- **Page+Scroll - all variants:** Jump directly to the "HOME page." The current operating level remains unchanged. If the HOME page is already selected, these buttons will perform the custom function. The default is Alarm Acknowledge.
- **Raise+Lower (Run/Hold):** If a programmer option is enabled and a program is configured, a momentary press of these keys toggles between Run and Hold modes.
- **Change Setpoint (SP Shown):** If setpoint is shown on the HOME page then using the "Raise" & "Lower" buttons can be used to change Setpoint. For step by step instruction on how to show Setpoint on the HOME page: Go to 1.4 .
  - **Raise:** The raise button increments parameter values to limits.
  - **Lower:** The lower button decrements parameter values to limits.
- **Change Setpoint (SP Not Shown):** If Setpoint is not shown on the HOME page then you will need to get into Level 2 to change the Setpoint. Hold "Page" for 3 seconds, to get to the Goto Parameter. Press "Raise" button then press the "Scroll" button, it will bring you to a Code Page. The code to get into Level 2 is 0002 use the "Scroll" and the "Raise" and "Lower" buttons to enter the password. Press "Scroll" to enter password. Press "Scroll" to get to SP1, use the "Raise" & "Lower" buttons to adjust Setpoint to desired Pressure.
- **F1 and F2:** the functionality of these buttons is set by the Instrument function block. The default settings are:
  - F1: Auto/Man
  - F2: Run/Hold

**NOTE:**

A time-out applies to all displays. If no button presses are detected within a timeout period (default is 30 min.), the display will revert back to the "HOME screen."

### 1.2 CONTROLS STARTUP: Setting PIDs

We recommend you Auto-tune your PIDs when first running the unit to optimize the controller for the application. Follow the below steps to set PIDs or to Auto-tune the EPC.

#### CAUTION!

- When programming the PID we recommend removing the jumper between C & LA or disconnecting the high voltage line if the unit does not have a transformer option.

1. Access the EPC controller main screen which is shown below:



2. Press and hold page button  on the main screen until following screen appears:





3. Click on raise button  to see the following screen:



4. Click on scroll button  and you will see passcode screen as shown below:





5. Click on scroll button  again to move to the next digit, and use arrow buttons   to select the passcode. The default passcode is **0002**. When entered correctly you will see the below screen:



6. Click on scroll button  until you reach the PB.H (Proportional Band) screen:

## SECTION 1: EPC CONTROLLER

7. It should be defaulted to “13”, if it is not “13” feel free to change it now with the arrow buttons   if you are not going to Auto-tune the controller to your specific application:



8. Press on scroll button  and you will see the Integral Time screen TI:



9. Like the Proportional Band this can be adjust this to our default “36” if not already set or wait for the Auto-tune process select the values.

**The following steps will help you auto tune your unit: if you wish to leave the unit with its default values hold , then press  and  to return to the Level 1 Screen. The unit will automatically log you out of level 2 in about 1 minute.**

10. Click on scroll button  a few time and you will reach the T.HI (Auto-tune high limit) screen:



11. T.HI should be set to no lower than “50%” but we recommend “100%” for more optimal PIDs.

12. Click on scroll button : it will cycle you through the rest of the options. We want to go back to an option we previously past called “TUNE”.



### CAUTION!

- In order to Auto-tune the unit, steam outlet piping will need to be connected and there will need to be some demand for steam on the unit.
- Take safety precautions as the unit will need to live and will be connected to high voltage to run an Auto-tune. The unit will also produce live steam.

13. Once safety precautions are taken, press the raise button  to Auto-tune.

14. Not touching any buttons for 1 minute will return you to the Level 1 screen while the unit Auto-tunes

### 1.3 DATA COMMUNICATIONS

Sussman Electric Boilers control system allows the controller to communicate with external Building Automation System (BAS) or Energy Management System (EMS). It is compatible with standard Modbus RTU or TCP/IP and BACnet UDP/IP multi-protocols. Optional gateway is also available for communications with other protocols.

- Communication between HMI and Temperature controller is standard Modbus RTU.
- Use RJ45 port to connect PC or network computer system with PID controller.

#### WARNING!

- Maximum communication cable lengths without repeater  
 RS485 Network – 4,000 feet  
 Ethernet Network – 328 feet
- Communications and power wiring should never be routed together inside same conduit because it can cause nuisance related issues on communications side.

#### NOTES:

- To help prevent ground loops, the cable shield should be grounded at one point only.
- Use twisted, shielded-pair communication wiring.
- Modbus serial (RS485) communication port is utilized to communicate with HMI. RJ 45 (Ethernet) port is available to communicate with building automation system.

#### 1.3.1 PID Controller Terminals Layout

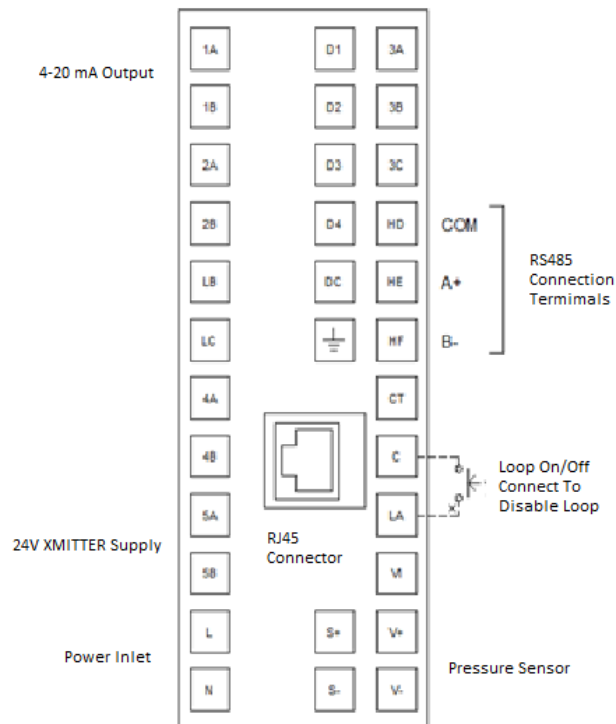

Where HD is Ground, HE (A+) receives data and HF (B-) transmits data



### 1.3.2 DHT controller communication features

1. DHT controller auto-detect the protocol of Modbus TCP/IP, BACnet UDP/IP.
  - a. The two protocols share the same IP addresses, Subnet masks, default gateways.
  - b. Auto-Discovery Mode – known as Zero-configuration networking (zeroconf)
    - i. Utilized Bonjour Service released by Apple under a terms-of-limited-use license.
    - ii. It is intended to use with itools (Eurotherm), not third party applications
    - iii. The Bonjour™ service is enabled by default which makes it easier for a malicious user to discover and access the controller via the network.
  - c. DHCP Mode
    - i. Default: OFF
    - ii. Enabling DHCP will auto-configure IP address, Subnet Masks, default gateway.
    - iii. Dynamic IP addressing.
  - d. Static Mode
    - i. Default: ON
    - ii. User can manually set up IP address, Subnet Masks, default gateway.
2. Ability to connect through Modbus RTU protocol.

#### **WARNING!**

Auto-discovery is on as the default option for simple and quick field setup. However, it makes it easier for a malicious user to discover and access the controller via the network.

### 1.3.3 DHT Default Settings Summary for communication

1. Auto-detection of Modbus TCP/IP, BACnet UDP/IP protocols, when connecting RJ45 port on the controller.
  - a. Default Mode: Static (Need to manually set parameters)
  - b. Default IP: 192.168.111.222
  - c. Default Mask: 255.255.255.0
  - d. Default Gateway: 0.0.0.0
  - e. Mac is read-only (Introduced in the instruction)
2. Ability to connect to Modbus RTU when wiring to HD (COM), HE (A+), HF (B-).
  - a. Default Baud Rate:19200
  - b. Default Parity: None
  - c. Default Data Length: 8
  - d. Default Stop Bits: 1
  - e. Default Slave ID: 1

### 1.3.4 Modbus RTU Communication Wiring

**NOTE:**

Up to 32 units can be connected in a daisy chain network including BAS Master.

Single unit wiring:

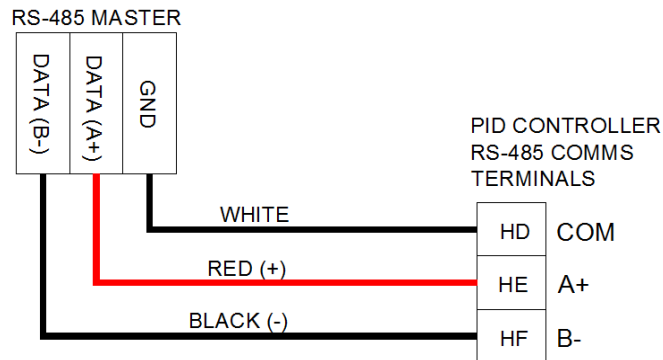

Multiple units' daisy-chain wiring:

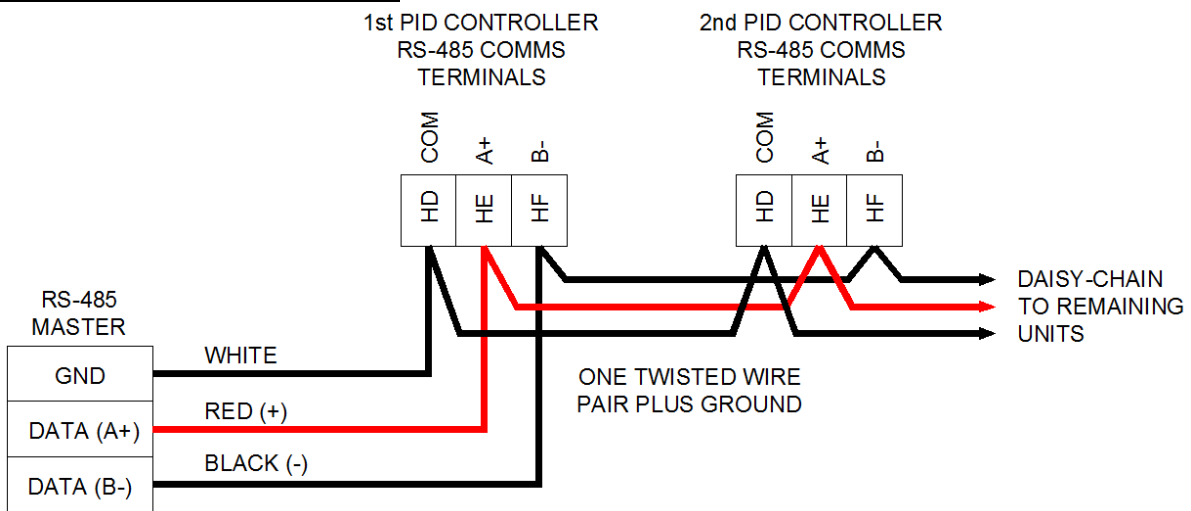

### 1.3.5 Modbus/BACnet Data Addresses and Points

Item Description	Type	Modbus Address	BACnet Address	Register	Comments
Remote/Local Setpoint	float32	2	Analog Value #38	RW	2-100PSI Range (15PSI Default)
Unit Remote On/Off	float32	277	Analog Value #53	RW	0: Off 1: On
Pressure in Vessel	float32	289	Analog Input #1	RO	2-100PSI Range
Output %age	float32	4	Analog Input #10	RO	0-100% Range
High Pressure Alarm Status	bool	2149	Binary Input #10	RO	0: Off 1: On (Default 20PSI above Setpoint)
Sensor Status	Unit8	1932	MSI#1	RO	0: Good 1: Fail

**Notes:**

1. Modbus decimal address is offset from 400001
2. Abbreviations
  - a. RO – Read Only
  - b. RW – Read/Write

### 1.3.6 Instructions to Change Communication Settings Manually

IP addresses, Subnet Masks and default gateway

#### CAUTION!

- Do not power off the controller without completing all the steps in the configuration settings. Save and go back to the main screen.
- Configurations settings shall be performed only by trained and experienced personnel.
- Proper care must be taken to prevent any changes to other settings in the configurations.

15. Access the EPC controller main screen which is shown below:



16. Press and hold page button  on the main screen until following screen appears:



## SECTION 1: EPC CONTROLLER

17. Now release the button. Again press and hold page button  until following screen appears:





18. Use raise and lower  buttons in the next step to navigate to the following screen:



19. Click on scroll button  and you will see passcode screen as shown below:



20. Click on scroll button  again to move to the next digit, and use arrow buttons

  to select the passcode. The default passcode is **0004**.

21. If the entered passcode is correct, it will direct to configuration menu screen:



22. Now click on page button  and you will see following screen:



23. Click on page button  until "COmm" appears on the screen:



## SECTION 1: EPC CONTROLLER

24. Click on scroll  button and you will see F.COM:



25. Use arrow buttons   to select the O.Com:



From the sub-menu, you are able to set up the parameters for BACnet/Modbus IP.

26. Click on scroll button  and you will see "mAIN" screen:



## SECTION 1: EPC CONTROLLER



27. Click on raise button  to select , then click on scroll button ,

and you will see  (Auto-discovery mode):



\*Default is OFF.

28. Click on  to move to the IP.MODE. Use arrow button to switch the mode:

- a.  is static mode – IP, Gateway, Subnet masks shall be manually setup
- b.  is DHCP mode – DHCP server shall be setup to assign IP, etc.

29. Click  to move to set up IP addresses. You will see the screen:

- a. 
- b. Use arrow buttons to change the IP addresses if required.

30. Continue to click  to see subnet masks (Indicator: IP.S1, IP.S2, IP.S3, IP.S4):  
a. Use arrow buttons to change the subnet masks if required.

31. Continue to click  to see default gateway (Indicator: IP.G1, IP.G2, IP.G3, IP.G4):  
a. Use arrow buttons to change the default gateway if required.

32. Continue to click on  to see mac addresses.

33. After setup, click  until you see:





34. Click arrow button until you see the screen below for BACnet setting



35. Click  to see parameter device ID for BACnet:



Use the arrow buttons to change device ID if required.

36. After the setup is complete, press and hold button , until the following screen appears:



37. Click on  to go back to the main screen and the settings will be saved.

38. Now the controller is ready for normal operation.

### 1.4 Adding Setpoint to HOME Page

The following step can be skipped if controller is already displaying Setpoint under actual pressure.

#### CAUTION!

- Do not power off the controller without completing all the steps in the configuration settings. Save and go back to the main screen.
- Configurations settings shall be performed only by trained and experienced personnel.
- Proper care must be taken to prevent any changes to other settings in the configurations.

1. Access the EPC controller main screen which is shown below:
2. If the entered passcode is correct, it will direct to configuration menu screen:



3. Now click on page button  until you will see following screen:



4. Click on  to configure the instrument and see the below screen:



5. Click on raise button  to see the following screen:



6. Press  you will see the home display screen that most looks like the following screen.



7. Click on raise button  until the below screen appears:



8. After the setup is complete, press and hold button , until the following screen appears:



9. Click on  to go back to the main screen and the settings will be saved.

10. Now the controller is ready for normal operation.

### 1.5 DRY CONTACTS

The following two types of contacts are available for remote monitoring of unit:

#### 1.5.1 Contact closure input (enable/disable)

Dry Contacts C and LA are available on the PID temperature controller to remotely start/stop the unit if required.

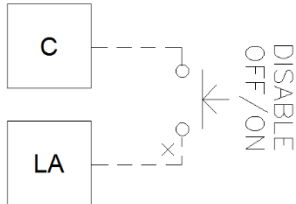

This input is supplied with the current transformer. Contact closure on the remote switch enable (start) the unit.

(This page intentionally blank)



**Change Log:**

Date	Description	Changed By
08/26/2024	Current Draft	SC