

# STP SERIES

## TANK AND PLATE STORAGE WATER HEATER

---

### FEATURES:

- Recovery rates from 600 to 10,800 GPH with 180°F boiler water for 100°F temperature rise
- Tank Sizes ranging from 80 to 765 gallons standard, with larger sizes by special order
- Domestic storage temperature control range 50-180°F.
- Double Wall Brazed Plate Heat Exchanger - 316L stainless steel plates. (AHRI 400 Rated)
- Compact Footprint
- Modular design with simplex and duplex (>175 Gal.) heat exchanger options available for built-in redundancy and extra capacity
- NEW Advanced Electronic PID controls with touchscreen user interface and compatible with Building Management System via ModBus IP or built-in BacNet IP
- Temperature control options:
  - o Standard: Using either VFD pump or 2-way or 3-way control valve on boiler water side (modulating heat input)
  - o Optional Simple control: Domestic solution with pump enable/disable based on aquastat to maintain domestic water storage temperature set point
- Storage Tank Material:
  - o Standard: Carbon steel Tank with double glass lining
  - o Optional: Power anodes with carbon steel tanks
  - o Optional: Duplex stainless steel (>175 Gal.)
- Fully Assembled- Skid Mounted Package for quick and easy single point connections
- Certifications: ASME, UL (Controls)
- Warranty: Heat Exchanger non-prorated (5) year, Steel Tank with Double Glass Lining (10) year, Duplex Stainless Steel Tank (25) year



The STP Series is a fully packaged storage water heater that utilizes a compact double wall brazed plate heat exchanger that optimizes heat transfer by generating more efficient hot water replenishment of the storage tank. Ideal for a variety of new and retrofit water-to-water heating applications that require little to large storage volume capacities

Installation is simple in both retrofit environments and new facility designs. The STP Series has a compact footprint and comes fully assembled in a skid-mounted package for quick and easy single point connections. For those with limited space conditions the piping and wiring connections can be easily removed and assembled so you can easily move the unit components inside the building.

## APPLICATIONS:

- Ideal for new or retrofit installations
- Suitable for both single or multiple unit installations
- Support variety of water to water heating applications including:
  - Apartment Complexes
  - Prisons / Correctional Facilities
  - Hospitals/ Nursing homes/ Medical Centers
  - Hotels/ Entertainment Facilities
  - Schools/ Colleges/ Universities/ Dormitories
  - Commercial laundries
  - Government & Office buildings

## DIMENSIONS:

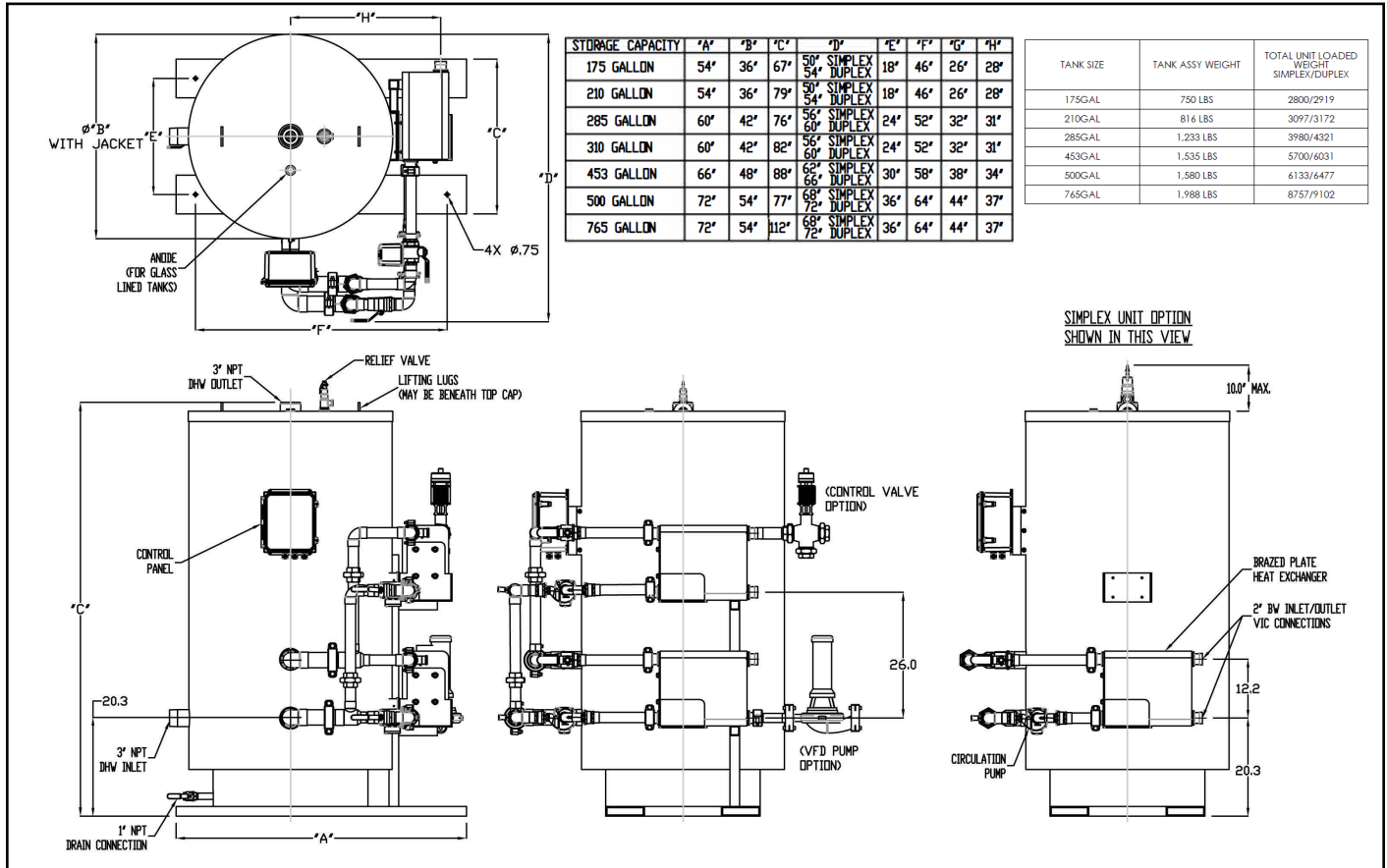

NOTE: The simplex and duplex heat exchanger units share the same dimensions and the only difference is that the simplex unit does not have top heat exchanger.

## SPECIFICATIONS:

Electrical Requirements	110V/1Ph/60Hz or 220/1/50Hz
Standby Amperage Draw	1 Amp
Full Load Amperage Draw	Simplex Unit: 2 Amp, Duplex Unit: 4 Amp
Ambient Temperature	32-110°F
Max. Continuous Water Flow	150 GPM
Max. Boiler Water Pressure & Temperature	150 PSIG (standard) Contact factory for high pressure applications
Max. Domestic Water Operating Pressure	150 PSIG (standard) Contact factory for high pressure applications
Adjustable Temperature Control Set Point	Up to 180°F
Accuracy	+/-4°F
Water Inlets/Outlet Connection Sizes	3.00" NPT
Standard Listing & Approvals	ASME SEC. IV HLW

## DIMENSIONS: STP JR (80/120 Gallon)

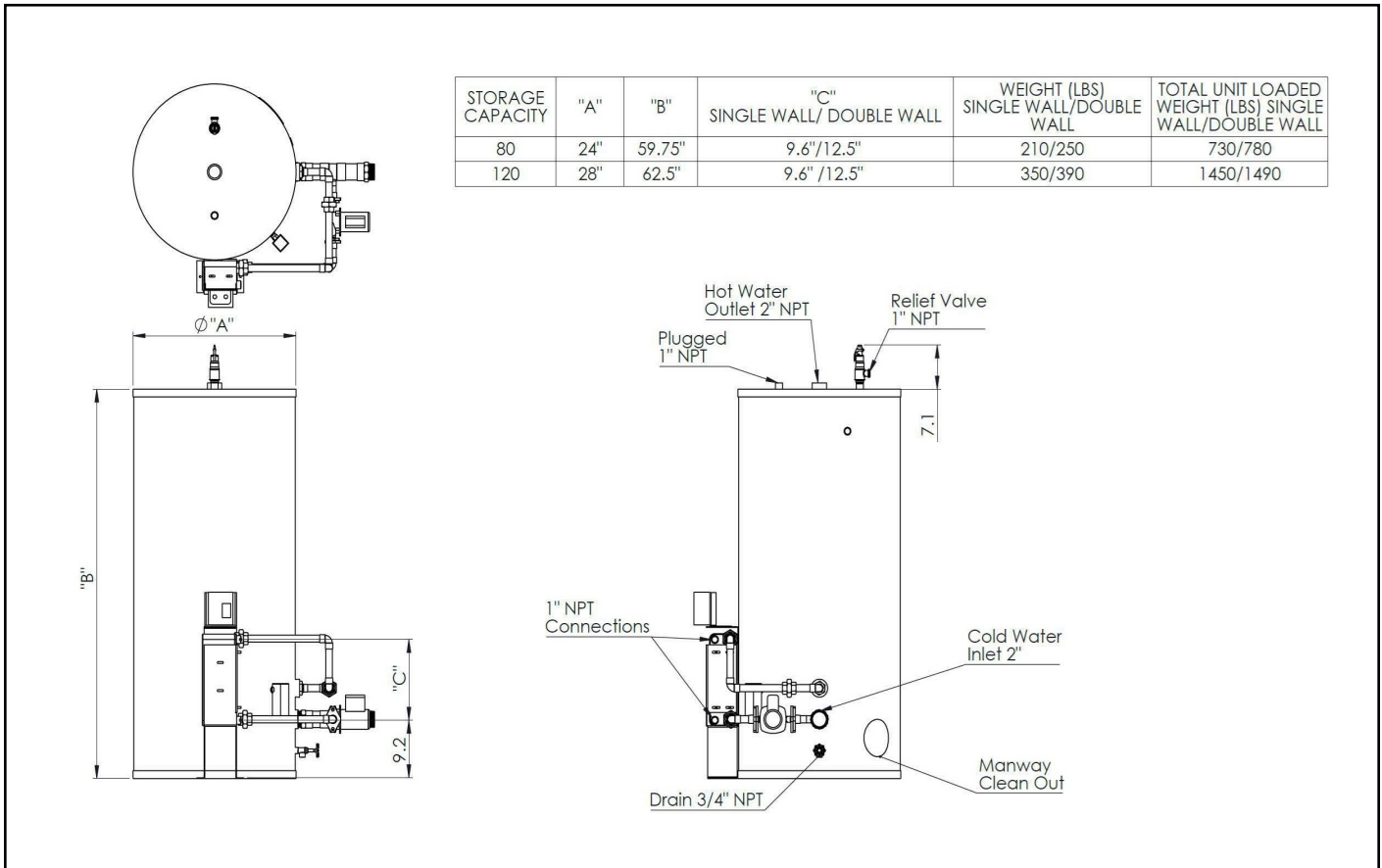

## SPECIFICATIONS:

Electrical Requirements	110V/1Ph/60Hz or 220/1/50Hz
Standby Amperage Draw	1 Amp
Full Load Amperage Draw	Simplex Unit: 2 Amp
Ambient Temperature	32-110°F
Max. Continuous Water Flow	45 GPM
Max. Boiler Water Pressure & Temperature	150 PSIG
Max. Domestic Water Operating Pressure	150 PSIG
Adjustable Temperature Control Set Point	Up to 180°F
Accuracy	+/-4°F
Water Inlets/Outlet Connection Sizes	Domestic 2.00" NPT, Boiler 1.00" NPT
Standard Listing & Approvals	ASME SEC. IV HLW

## PID CONTROL SYSTEM:

### FEATURES:

- 4.3 HMI Touchscreen
- Feedforward Logic Controller includes 1/8 DIN with LCD display (back-up interface)
- Data Logging
- Fault Log
- Trending/Graphing
- Compatibility with Modbus IP and BacNet IP BAS system standard without the need for external gateway.
- A gateway can be used for all other protocols

NOTE: Controller available for 175 Gal. and higher models only.



DHT designed advanced electronic PID controls for the STP Series. It features a 4.3-inch TFT color touchscreen user interface and is compatible with a Building Management System via ModBus IP or built-in BacNet IP. The DHT state-of-the-art control system offers unmatched performance and full user configurability for water heater applications.

The PID controller supports the overall performance of the STP Series to achieve accurate temperature control over various demand situations. A millivolt signal is transmitted from a durable temperature sensor directly into the advanced PID controller, which in turn sends a signal to the electrically activated fully modulating and fast acting three-way control valve with high turndown.

### SPECIFICATIONS:

Enclosure Dimensions	12”H x 10” W x 7” D
Display	4.3” TFT Color LCD
Graphics Display Resolution/ Colors	480 x 272 pixels w/ 65,536 display colors
Backlight	White LED, service life 50,000 hours and 24hr operation
Brightness control	16 Levels (Adjusted with touch panel)
Operating Mode	Single Tone, Visual Indicator
Memory:	8Gb
Supply Voltage	120/240 VAC
Certifications	NEMA 4, UL