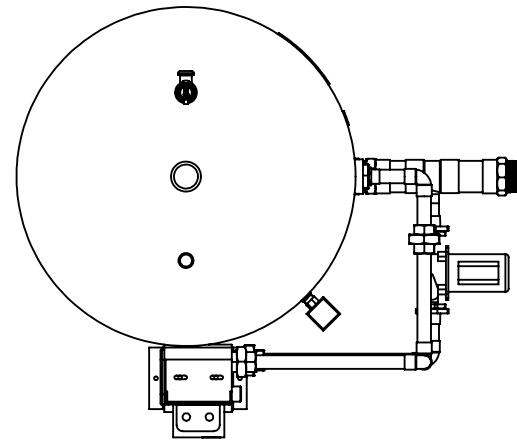
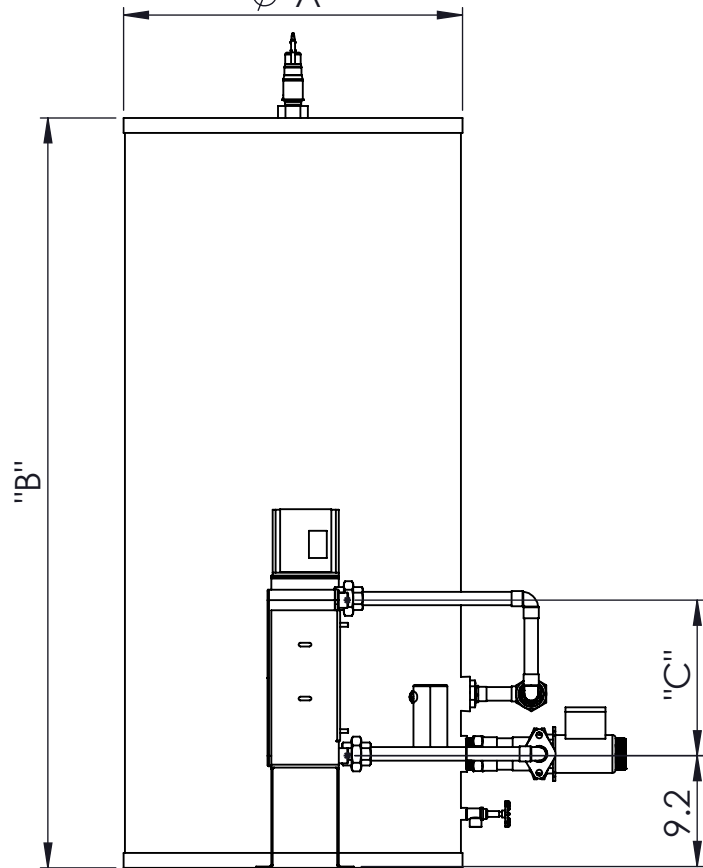

4

3

2

1

 $\phi$  "A"

STORAGE CAPACITY	"A"	"B"	"C"		WEIGHT (LBS)		TOTAL UNIT LOADED WEIGHT (LBS)
			SINGLE WALL/	DOUBLE WALL	SINGLE WALL/DOUBLE WALL	SINGLE WALL/DOUBLE WALL	
80	24"	59.75"	9.6"/	12.5"	210/250	730/780	
120	28"	62.5"	9.6" /	12.5"	350/390	1450/1490	

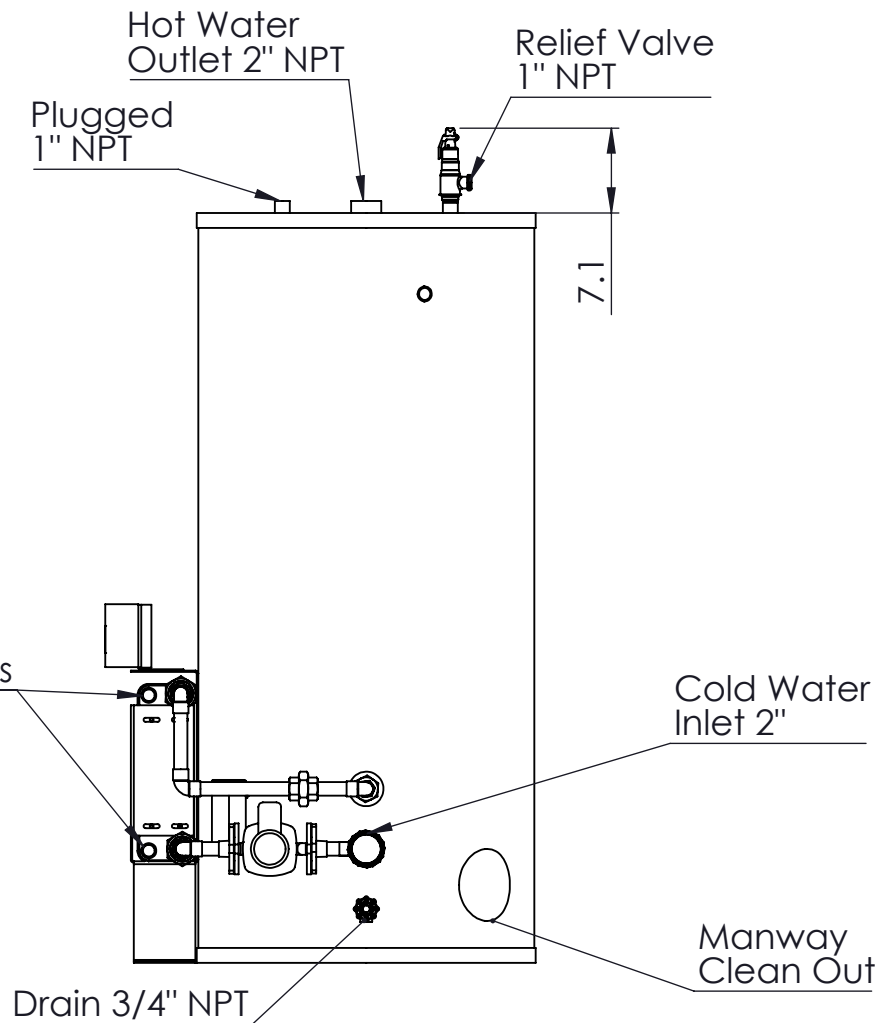

## NOTES:

- DHT RESERVES THE RIGHT TO MODIFY DIMENSIONS WITHOUT PRIOR NOTICE.
- DO NOT COMPLETE FIELD PIPING UNTIL UNIT IS PROPERLY INSTALLED. ACTUAL DIMENSIONS MAY VARY DUE TO MANUFACTURING TOLERANCES. FABRICATION ACCEPTS NO LIABILITY DUE TO DIMENSIONAL VARIATION.
- RELIEF VALVE AND DRAIN VALVE PIPED TO DRAIN BY CONTRACTOR.
- REFER TO INSTALLATION AND PIPING DRAWINGS FOR MORE DETAILS.
- ADDITIONAL REDUCER/INCREASER MAY BE REQUIRED TO MATCH UNIT CONNECTION SIZES.
- T&P RELIEF VALVE DIMENSIONS ARE REFERENCE ONLY AND VARIES WITH RESPECT TO THE SELECTION FOR HEATING CAPACITY.
- INSULATION THICKNESS IS 4 INCHES WITH AN R-VALUE OF 15.
- STORAGE TANK AVAILABLE IN BOTH CARBON STEEL WITH DOUBLE GLASS LINING AND DUPLEX STAINLESS STEEL MATERIAL OPTIONS. RATED AT 150PSI OPERATING PRESSURE.

DIMENSIONS ARE SHOWN IN INCHES [CENTIMETERS]  
TOLERANCES ARE AS FOLLOWS UNLESS OTHERWISE SPECIFIED  
X.XX X.XXX X.XXXX ANGULAR FINISH  
 $\pm .12$   $\pm .031$   $\pm .0156$   $\pm 1.0^\circ$  250  
REMOVE AND DEBURR SHARP EDGES AND CORNERS  
ALL DIMENSIONS ARE AFTER FINISH OR PLATING  
REFERENCE DIMENSIONS ARE SHOWN IN PARENTHESES ( )  
CRITICAL DIMENSIONS ARE SHOWN IN  $\square$

THIS DRAWING AND/OR SPECIFICATIONS ARE THE PROPERTY OF DIVERSIFIED HEAT TRANSFER INC. THIS CONFIDENTIAL AND PROPRIETARY INFORMATION SHALL NOT BE USED, COPIED OR REPRODUCED IN ANY MEANS AS THE BASIS FOR MANUFACTURE OR SALE OF APPARATUS WITHOUT WRITTEN AUTHORIZATION FROM OWNER.

THIRD ANGLE PROJECTION



DWG. SCALE

1:16

MATERIAL SPEC:

**DIVERSIFIED**  
HEAT TRANSFER INC.

439 MAIN RD. TOWACO NJ 07082

PHONE: (800) 221-1522 FAX: (718) 386-7809

TITLE

 STPJR SERIES  
DIMENSIONAL DRAWING

DRAWN BY

NAME

JH

DATE

4/1/26

DWG#

STPJR-90021

REV

A

CHECKED BY

SHEET 1 OF 1

4

3

2

1