



EWx Series

Electric Hot Water Boiler (30kW - 1200kW)

Covers 43 different EWx models from EWx300 through EWx1200



CONTRACTOR / FACILITY INFORMATION
NOTE: This user manual must always accompany the specific unit as recorded below:

Model #: _____

Serial #: _____

Install Date: _____

DISCLAIMER The information contained in this document is subject to change without notice from Diversified Heat Transfer, Inc. (DHT). DHT makes no warranty of any kind in respect to this material, including but not limited to, implied warranties of merchantability and fitness for a particular application. DHT is not liable for errors appearing in this document, nor for incidental or consequential damages occurring in connection with the furnishing, performance, or use of these materials.

Table of Contents

Table of Contents	2
Section 1: Introduction	5
Purpose of Manual	5
Warning & Cautions:.....	5
Disclaimers and Local Codes	6
Safety Signal Words.....	7
Operator Responsibility	7
Proper Training	8
Section 2: Product Overview.....	8
Product Overview	8
Applications.....	10
Intended Use	11
Compliance and Certifications	11
Boiler Identification	11
Warranty and Support.....	12
EWx Unit Specifications.....	12
Design Conditions.....	12
Vessel and Component Design	13
Pressure Drop and Flow Characteristics.....	14
System Water Quality Requirements	16
Mechanical Assembly	17
Controls	17
Control Cabinet	18
Operating Precautions.....	18
SECTION 3: RECEIPT, INSPECTION, AND PLACEMENT.....	21
Receipt and Inspection.....	21
Placement, Rigging, and Site Preparation	22

Rigging and Handling.....	22
Site Preparation.....	23
Floor Loading	24
Electrical Grounding.....	25
Environmental Conditions	25
Installation Requirements	26
Piping Installation and Unit Connections.....	35
Plumbing Requirements	35
Electrical Wiring.....	38
Power Feed Wiring.....	43
Equipment Grounding Conductors.....	44
Short Circuit Current Rating (SCCR)	44
Control Circuit Wiring.....	60
Field Input And Output Control Wiring Connections.....	61
Section 4: Operation and Controls	62
General Description	62
Preparation For Operation	63
Startup Procedure	64
Operation Modes	66
Section 5- EWx Control Functions	68
Controls Introduction	68
Safety Information – Controls & Start-Up.....	68
Overview of On-Screen Navigation.....	69
Key Display Descriptions	72
STATUS Base Display.....	74
Mechanical & Electrical Start-Up (Summary).....	88
Controls Start-Up – Powering and Initial Operation	89
Setup Wizard Procedures	90
Application-Specific Start-Up	102

Basic Use of Diagnostic Screens	106
Modbus/BACnet Data Addresses and Points	110
Section 6- Maintenance & Troubleshooting.....	111
General Maintenance Philosophy.....	111
System Review Items.....	112
Maintenance Schedule Overview	113
Electric Heating Element and Power Train Maintenance	115
Insulation Resistance and Moisture Considerations	118
Controls and HMI Maintenance	119
Cleaning and Inspection Procedures.....	120
Troubleshooting Guide (Maintenance Focus).....	121

Section 1: Introduction

Purpose of Manual

This manual provides essential information for the installation, operation, and maintenance of the Sussman EWx Series Electric Hot Water Boiler. It is intended for qualified personnel, including installers, service technicians, and facility engineers—responsible for ensuring safe, reliable, and efficient operation.



The EWx Series includes the following model ranges:

- EWx30-EWx120
- EWx150-EWx240
- EWx270-EWx600
- EWx630-EWx960
- EWx990-EWx1200

Proper adherence to the procedures in this manual is critical to maintain compliance with ASME, UL, and NFPA standards and to ensure the performance, efficiency, and longevity expected of Sussman Electric Boilers.

Warning & Cautions:

WARNINGS and CAUTIONS appear throughout this manual. All personnel must read and understand these notices before performing any installation, operation, or maintenance tasks. Strict compliance is required to protect personnel and equipment.

-  **WARNING** — Indicates a potentially hazardous situation that could result in serious injury or death.
-  **CAUTION** — Indicates a condition that may result in equipment damage, system malfunction, or reduced performance.

These safety notices are not a substitute for proper training, safe work practices, or adherence to applicable codes and regulations. All work must be performed by qualified, authorized personnel following ASME, UL, NFPA, and local safety standards.

Disclaimers and Local Codes

Installation must conform to all applicable national, state, and local codes enforced by the Authorities Having Jurisdiction (AHJ). Where jurisdictional requirements differ from the general instructions in this manual, the local requirements take precedence.

In the absence of specific local requirements, installations within the United States must comply with:

- *National Electrical Code* (NFPA 70, latest edition)
- *ASME Section IV* – Rules for Construction of Heating Boilers
- *ASME CSD-1* – Controls and Safety Devices for Automatically Fired Boilers (when required by AHJ)
- *National Fuel Gas Code* (ANSI Z223.1/NFPA 54, latest edition)

Note: Always consult local authorities before installation to confirm applicable code requirements and necessary permits or inspections.

The EWx boiler heat exchanger (pressure vessel) is manufactured and stamped in accordance with ASME Section IV, rated for a maximum allowable working pressure (MAWP) of 160 psig and a maximum design temperature of 250°F (121°C). The EWx maximum operating temperature is 225°F (107°C).

Failure to comply with these standards or instructions may result in unsafe operation and void the manufacturer's warranty.

Safety Signal Words

Signal Word Meaning

DANGER	Indicates an imminently hazardous situation that, if not avoided, <i>will</i> result in death or serious injury.
WARNING	Indicates a potentially hazardous situation that, if not avoided, <i>could</i> result in death or serious injury.
CAUTION	Indicates a potentially hazardous situation that, if not avoided, <i>may</i> result in minor or moderate injury or equipment damage.
NOTICE	Used for statements not related to personal injury, such as operating tips or equipment care instructions.

Operator Responsibility

Operators and maintenance personnel must:

- Review and understand this manual before operating the boiler.
- Familiarize themselves with all controls, indicators, and safety devices.
- Verify proper installation of the power supply, piping, and pressure relief devices per code.
- Maintain water quality within specified limits to prevent scaling or corrosion.
- Keep the boiler area clean and free from combustible materials or obstructions.

Proper Training

Proper training is the best safeguard against accidents. All operating and service personnel must be thoroughly familiar with the construction, operation, and safety precautions of the EWx Series Electric Hot Water Boiler. If any part of this manual is not fully understood, contact Sussman Technical Service for guidance. Be prepared to provide the unit serial number, which can be found on the nameplate located on the front of the unit below the control panel.

Section 2: Product Overview



This manual provides reference and guidance only. It does not replace professional training, safe work practices, or compliance with applicable regulations.

The EWx Series Electric Hot Water Boiler is not suitable for use as a domestic water heater. Do not use the EWx boiler to heat potable water for showers, sinks, dishwashers, or other sanitary purposes. Improper use may result in contamination, equipment damage, or unsafe conditions.



The EWx boiler is certified for indoor installation only. Do not install outdoors or in areas subject to freezing, excessive moisture, or corrosive atmospheres unless specifically engineered and approved by Sussman Electric Boilers.

Product Overview

The Sussman EWx Series Electric Hot Water Boilers represent the next generation of clean, efficient, and modular hydronic heating systems. Designed for commercial and industrial environments,

the EWx delivers a safe, emission-free alternative to gas-fired boilers—offering precise control, rapid response, and low maintenance operation.

Each EWx boiler features a modular cast-iron pressure vessel with direct immersion resistive heating elements for rapid and uniform heat transfer. Multiple vessels can operate in parallel for increased capacity, redundancy, and serviceability—all within a compact footprint.

Using PID (Proportional–Integral–Derivative) control integrated with SCR (Silicon Controlled Rectifier) or SSR (Solid State Relay) power regulation, the EWx maintains temperature accuracy within $\pm 2^{\circ}\text{F}$ (steady state conditions) for superior energy efficiency and stable operation.

Key Performance Advantages

- Modular cast-iron design for scalability and compact installation
- Rapid response with direct immersion heating
- Zero on-site emissions, supporting decarbonization initiatives
- Advanced PID temperature control and smooth load modulation
- Quiet operation, low maintenance, and extended service life

Built in the USA and supported by DHT’s eight decades of heat transfer expertise, the EWx Series meets or exceeds ASME, UL, and NFPA standards for safety and performance.

Figure 1 – EWx Series Internal Components Layout (Typical)

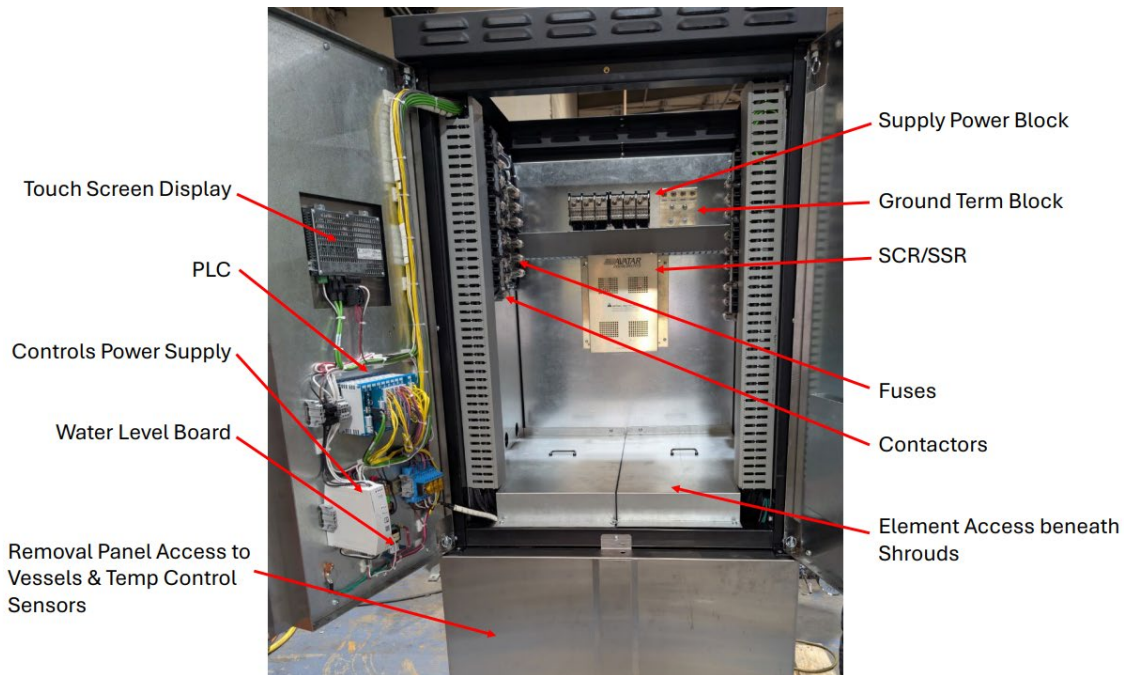

Applications

The EWx Series is ideal for commercial, institutional, and industrial hydronic heating applications—both new installations and retrofit projects require emission-free, reliable, and efficient hot water generation.

Typical Applications Include:

- Multi-family housing and apartment complexes
- Correctional facilities
- Hospitals, nursing homes, and medical centers
- Hotels, casinos, and entertainment venues
- Educational institutions
- Municipal and government buildings
- Commercial office buildings
- Industrial facilities

For system design or multi-boiler configuration assistance, contact Sussman Technical Support.

Intended Use

The EWx boiler is designed exclusively for heating water in closed-loop or hydronic systems operating within specified design pressures and temperatures.

It must not be used for steam service or any other purpose. Operating outside rated limits may cause equipment damage or unsafe conditions.

Compliance and Certifications

All Sussman EWx Series Electric Hot Water Boilers are constructed, tested, and labeled in accordance with the ASME Boiler and Pressure Vessel Code, Section IV, and are UL and cUL Listed for electrical safety. Each unit is CSD-1 compliant where required and built and tested in the USA.

Installation of the EWx Series must be performed only by qualified personnel in accordance with the instructions in this manual and in full compliance with all applicable national, state, provincial, and local codes and safety regulations established by the authorities having jurisdiction. It is the installer's responsibility to verify and obtain any additional approvals or certifications required for the specific installation location.

Boiler Identification

Each boiler is equipped with a nameplate listing:

- Model and serial number
- Voltage, phase, and frequency
- Full-load amperage and kW rating
- MAWP and temperature limits

Always reference these numbers when contacting Sussman Technical Support for service, parts, or warranty information.

Warranty and Support

Sussman Electric Boilers provides a standard warranty covering defects in materials and workmanship under normal use from the date of shipment.

For technical support or service:

Sussman Electric Boilers (A Brand of Diversified Heat Transfer)

439 Main Road, Route 202, Towaco, NJ 07082

800-221-1522 | www.sussmanboilers.com | seb@dhtnet.com

EWx Unit Specifications

Maximum Amperage Draw per Unit per Voltage

Tables in section 3 provide Full Load Amperage (FLA) draw, Minimum Circuit Ampacity (MCA), and Maximum Overcurrent Protection (MOCP) electrical ratings for each EWx configuration.

All values are based on nominal conditions and may vary slightly based on voltage supply, element configuration, and control options.

Installers must verify all electrical data against the boiler nameplate, the National Electrical Code (NFPA 70), and local regulations to ensure correct conductor sizing, overcurrent protection, and grounding.

DESIGN CONDITIONS

Each EWx boiler is engineered and manufactured to ASME Section IV standards for maximum safety, reliability, and efficiency.

The series accommodates various capacities, voltages, and control packages designed to operate within the following standard conditions:

STANDARD DESIGN CONDITIONS:

Parameter	Specification
ASME Construction	Section IV, Heating Boiler
Maximum Allowable Working Pressure (MAWP)	160 psig
Maximum Design Temperature	250°F (121°C)
Maximum Operating Temperature	225°F (107°C)
Minimum Operating Temperature	40°F (4°C)
Maximum Operating Temperature	225°F (107°C)
Minimum Ambient Temperature	40°F (4°C)
Maximum Ambient Temperature	104°F (40°C)
Minimum Flow Rate	As specified in model data (refer to pressure drop curve)
Maximum Flow Rate	As specified in model data (refer to pressure drop curve)
Pressure Drop	Refer to published pressure drop curves for specific model

***NOTE:** Always confirm certified pressure and temperature ratings on the unit nameplate and relief valve tag.*

Vessel and Component Design

Each boiler features a cast ductile iron, **ASME-certified pressure vessel and manifolds** equipped with:

- Immersion-type electric heating elements in flanged, removable assemblies
- Heavy-duty contactors and control circuits for proportional load control
- Manual reset low-water cutoff
- Manual-reset high-limit and operating temperature limit controls, automatic reset
- ASME-certified safety relief valve sized for full-load discharge

All components are selected and integrated for consistent, reliable hot water generation under rated conditions.

Pressure Drop and Flow Characteristics

Optimized internal flow passages minimize pressure loss and promote uniform heat transfer. System design must ensure:

- Flow remains within model-specified limits
- Continuous circulation is maintained to prevent overheating
- Pumps are properly sized to overcome system and boiler head losses
- For boiler delta T above 60F, contact factory.

Figure 2 – EWx Series Pressure Drop Per Unit

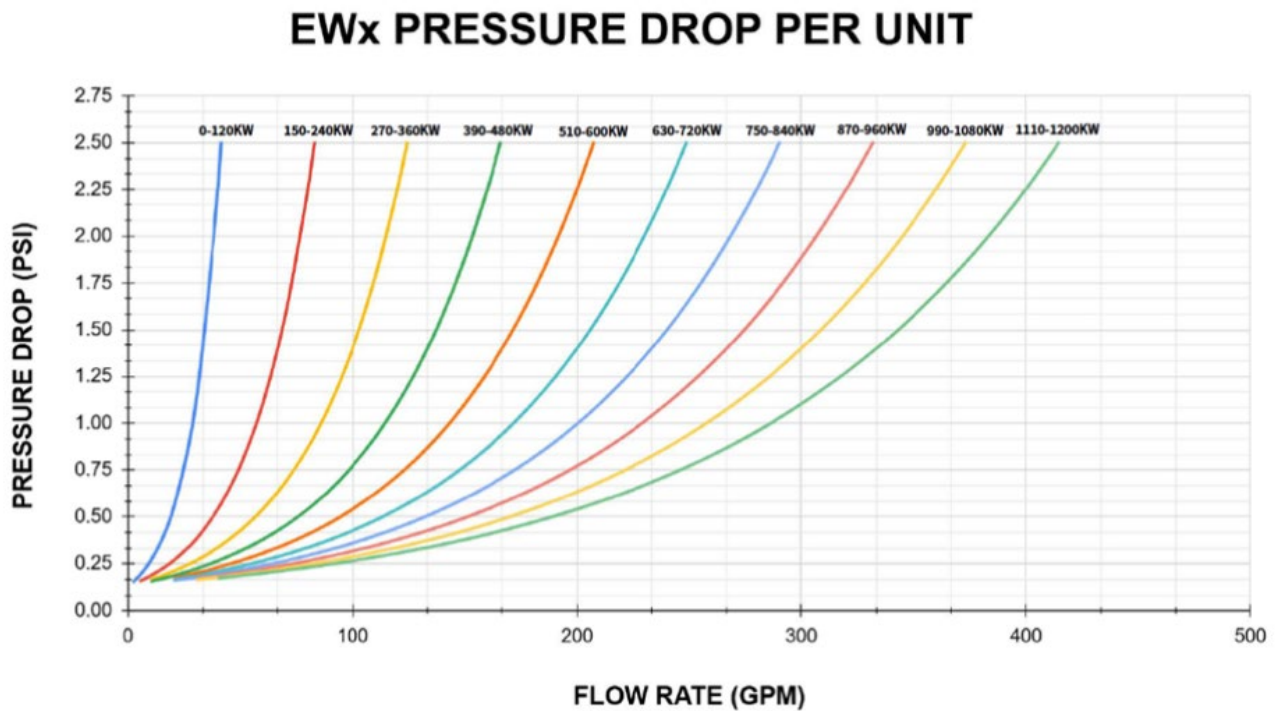

Figure 3 – EWx Series Minimum and Maximum Water Flow

EWx Boiler Minimum and Maximum Water Flow - GPM				
EW Models	kW	MBH	Miniumun GPM	Maximum GPM
EWx30	30	100.3	4	41
EWx45	45	150.5	4	41
EWx60	60	200.6	4	41
EWx75	75	250.8	4	41
EWx90	90	300.9	4	41
EWx105	105	351.1	4	41
EWx120	120	401.3	4	41
EWx150	150	501.6	8	82
EWx180	180	601.9	8	82
EWx210	210	702.2	8	82
EWx240	240	802.5	8	82
EWx270	270	902.8	12	123
EWx300	300	1,003	12	123
EWx330	330	1,103	12	123
EWx360	360	1,204	12	123
EWx390	390	1,304	16	164
EWx420	420	1,404	16	164
EWx450	450	1,505	16	164
EWx480	480	1,605	16	164
EWx510	510	1,705	20	205
EWx540	540	1,806	20	205
EWx570	570	1,906	20	205
EWx600	600	2,006	20	205
EWx630	630	2,107	24	246
EWx660	660	2,207	24	246
EWx690	690	2,307	24	246
EWx720	720	2,408	24	246
EWx750	750	2,508	28	287
EWx780	780	2,608	28	287
EWx810	810	2,708	28	287
EWx840	840	2,809	28	287
EWx870	870	2,909	32	328
EWx900	900	3,009	32	328
EWx930	930	3,110	32	328
EWx960	960	3,210	32	328
EWx990	990	3,310	36	368
EWx1020	1020	3,411	36	368
EWx1050	1050	3,511	36	368
EWx1080	1080	3,611	36	368
EWx1110	1110	3,712	40	409
EWx1140	1140	3,812	40	409
EWx1170	1170	3,912	40	409
EWx1200	1200	4,013	40	409

SYSTEM WATER QUALITY REQUIREMENTS

Boiler water quality has a significant impact to the operation and longevity of hot water boilers. The boiler water should be tested prior to initial startup. If the mineral content exceeds the following recommended limits, various external treatment processes (water softener, reverse osmosis, etc.) should be used to correct the problem.

***NOTE:** An analysis of the on-site boiler feedwater must be made by a recognized and reliable water treatment company to ascertain the existing condition and treatment required.*

RECOMMENDED WATER QUALITY:

Ph (strength of alkalinity)	Range of 8.5 - 10.5
Oxygen	Less than 250 ppb (operating condition)
Total Iron/Copper	Less than 5 ppm
Chloride	Less than 200 ppm
Hardness	Less than 3.5 grains per gallon (60 ppm) in make-up/fill water. Calcium buildup on heating surfaces is not covered under warranty.
Corrosion Inhibitor	Capable of maintaining iron corrosion rates <2 mpy. A non-heavy metal ALL ORGANIC inhibitor is recommended which is designed for multi metal systems including ferrous metals and yellow metals such as copper and brass.

Adhere to the following:

Refer to your water conditioning or chemical treatment supplier for analysis and recommendations for proper system conditions.

Follow a program with appropriate monitoring and maintenance of system water conditions as provided by your water conditioning or chemical treatment supplier.

1. Operate the boiler in a closed-loop system using water or water/glycol (not requiring a make-up water supply). A large amount of improperly treated make-up water can cause premature failure of

the heating elements resulting from scale build up. Scale build up will reduce the efficiency and useful life of the boiler and is not covered under warranty.

2. For freeze protection, an inhibited propylene glycol is recommended. The maximum concentration is 50% glycol by volume. Only use mixtures formulated for hydronic systems. Do not use automotive glycol.

At a minimum, the hydronic fluid should be checked for glycol concentration and pH once a year, or per glycol manufacturer's schedule. A refractometer is recommended.

Mechanical Assembly

The EWx utilizes a modular cast-iron pressure vessel design for durability, serviceability, and long life.

Each ASME-stamped vessel is hydrostatically tested and connected via carbon steel header manifolds for balanced flow.

Depending on model, each vessel includes up to four (4) 30 kW low-watt-density Incoloy-sheathed heating elements for corrosion resistance and uniform heating.

This modular arrangement provides scalable capacity in a compact footprint.

Controls

The EWx control system offers advanced functionality through a 7-inch capacitive resistive touchscreen (1024 × 600 resolution), featuring:

- PID Control with SCR or SSR power regulation (0–100% modulation)
- Multi-boiler sequencer for load balancing
- BACnet/IP, BACnet MSTP, Modbus IP, and Modbus RTU communication
- Password-protected user levels for secure access

All control systems are UL/cUL Listed for U.S. and Canadian compliance.

The optional control circuit transformer branch circuit includes equivalent protection. All replacement components must match original ratings to maintain certification.

For configuration or upgrade assistance, contact your Sussman Technical Service representative.

Control Cabinet

The control cabinet is a heavy-duty, steel enclosure designed for durability and service access.

- Hinged, key-lock doors for authorized access
- Fabricated from 0.063-inch (1/16") steel for strength and corrosion resistance
- Two-section layout:
 - Lower section: ASME vessels
 - Upper section: Electrical controls mounted on steel back panels with 2" air clearance for cooling
- Ventilation louvers (as applicable) for heat dissipation
- Industrial-grade powder coating for corrosion protection and professional finish
- Door interlock standard to interrupt the control circuit when the door is open.

Operating Precautions

To ensure maximum safety, performance, and reliability of the unit, the following precautions and procedures must be strictly observed:

1. **General Requirements**

- 1.1. The unit shall be installed, operated, and serviced only in accordance with the instructions contained in this manual.
- 1.2. Installation shall be performed in accordance with designs prepared by qualified facility engineers, including structural, mechanical, electrical, and other relevant disciplines.
- 1.3. The unit shall not be operated or serviced until a customer-specific safety training program has been established.

2. **Personnel and Compliance**

- 2.1. Operation and service shall be performed only by qualified technical personnel.
- 2.2. All work must comply with applicable local, state, and national codes, laws, and regulations.

3. **Operating Conditions**

- 3.1. The unit shall be used strictly within the specifications provided to DHT.
 - 3.2. Operating pressure and temperature must not exceed the limits indicated on the DHT nameplate attached to the unit.
 - 3.3. The heated fluids must be clean and free of debris.
 - 3.4. The unit shall operate only with water or a maximum 50% glycol/water mix, for which it was designed.
 - 3.5. The system must be designed to prevent the unit from experiencing pressure shocks.
4. **Startup and Maintenance**
- 4.1. For initial startup, follow all procedures outlined in Section 4: Startup Procedures.
 - 4.2. All strainers associated with the unit must be inspected and cleaned periodically.
 - 4.3. Refer to Section 3: Electrical Connections for proper grounding requirements.

Storage and Transportation

Store units in a clean, dry area protected from corrosive atmospheres and weather elements such as rain or snow. Indoor storage is preferred, with ambient temperatures maintained between 32°F and 110°F. During transportation, protect the units from mechanical damage and avoid exposure to temperatures outside the specified limits provided by DHT.

Safety Features

The customer is responsible for maintaining all safety features of the EWx Series Electric Hot Water Boiler, including guards, safety labels, safety controls, interlocks, and lockout devices.



WARNING

- **PRESSURIZED FLUIDS CAN CAUSE SERIOUS INJURY OR EQUIPMENT DAMAGE IF RELEASED.**

Before performing maintenance, close all incoming and outgoing water shutoff valves and carefully reduce any trapped pressure to zero.

- **ELECTRICAL SHOCK HAZARD.**

Before servicing, disconnect all electrical power to the unit at an external disconnect switch. Electrical voltages up to 600 VAC may be present.

The front panel door on the unit's power box must remain closed at all times, except during maintenance or service.

- **DISCONNECT REQUIREMENT.**

A three-pole switch must be installed on the unit's electrical supply line.

The switch must be located in an easily accessible area to allow quick and safe disconnection



CAUTION

DO NOT OPERATE THIS BOILER IF ANY PART HAS BEEN UNDER WATER.

Contact a qualified technician to inspect and replace any component that has been submerged before returning the unit to service. The manufacturer's warranty applies to closed-loop systems only.

SECTION 3: RECEIPT, INSPECTION, AND PLACEMENT

Receipt and Inspection

Each EWx Series Electric Hot Water Boiler is factory-tested and inspected prior to shipment to ensure performance and reliability. Upon receipt, carefully examine the boiler and all associated components for any signs of damage that may have occurred during transit or handling.

1. **Visual Inspection**

Inspect the exterior surfaces, electrical enclosures, and all pressure components for dents, cracks, or other visible damage.

2. **Component Verification**

Confirm that all pressure and control components match the design specifications and correspond to the data on the boiler nameplate and specification tags.

3. **Reporting Damage**

- a. Report any damage that could compromise the safe and reliable operation of the boiler immediately.
- b. File freight damage claims directly with the carrier.
- c. Notify Sussman Electric Boilers or your authorized sales representative for guidance on inspection results and corrective action.
- d. Have the following information available when contacting Sussman: model number, serial number, voltage, kilowatt rating (kW), and phase as shown on the nameplate.



WARNING

- **DO NOT INSTALL OR OPERATE THE BOILER UNTIL ALL DISCREPANCIES HAVE BEEN RESOLVED.**

Placement, Rigging, and Site Preparation

Proper placement of the EWx Series Boiler is critical for safe installation, efficient operation, and long service life. Installation must be performed by qualified personnel in accordance with national, state, and local codes. Improper installation may result in personal injury, equipment damage, or unsafe operating conditions.

General Requirements

Installation must comply with the following standards and regulations:

- ASME CSD-1: Controls and Safety Devices for Automatically Fired Boilers
- NFPA 70 (ANSI/National Electrical Code): Electrical wiring and grounding requirements
- ASME Boiler and Pressure Vessel Code, Section IV: As applicable
- Any additional jurisdictional codes required by the Authority Having Jurisdiction (AHJ)

Note: Consult with the AHJ before installation to ensure full compliance.



- **INSTALLATION MUST ONLY BE PERFORMED BY QUALIFIED PERSONNEL FAMILIAR WITH BOILER SYSTEMS, ELECTRICAL SAFETY, AND APPLICABLE CODES. FAILURE TO COMPLY MAY RESULT IN SERIOUS INJURY, DEATH, OR EQUIPMENT DAMAGE.**

Rigging and Handling

The EWx boiler is heavy equipment. Use proper rigging techniques to avoid injury or damage.

- Engage a qualified rigger experienced in handling industrial equipment.
- Use approved lifting equipment to ensure the load is evenly distributed and securely attached.
- Never lift or move the boiler by piping, heating elements, or control enclosure.

- Avoid applying load to any electrical or control components.



CAUTION

DAMAGE CAUSED BY IMPROPER RIGGING OR LIFTING IS NOT COVERED UNDER WARRANTY.

Site Preparation

- Provide a firm, level foundation; a reinforced concrete pad (3.5–8 inches thick) is recommended.
- Install on a non-combustible surface whenever possible.
- Secure the boiler using the L-brackets at each corner of the unit base.
- Ensure the boiler is plumb and level to maintain proper water flow and control performance.
- Maintain at least 18 inches of clearance above the unit for electrical connections (and service access on the EWx30-EWx120 models).
- Seismic anchorage data is available upon request; contact your Sussman Electric Boilers representative for details.



WARNING

FAILURE TO PROVIDE PROPER CLEARANCES OR SAFE ACCESS MAY PREVENT

COMMISSIONING OR SERVICING. Service personnel will not proceed if hazardous or restricted conditions exist. Inadequate clearance from combustibles may result in fire or severe property damage.

Floor Loading

Verify that the building structure and floor can safely support the total operating weight of the boiler and connected piping.

Figure 4 – EWx Series Nominal Boiler Weights

EWx NOMINAL BOILER WEIGHTS		
EWx KW	DRY WEIGHT (LBS.)	WET WEIGHT (LBS.)
30	415	473
45	427	485
60	427	485
75	438	496
90	438	496
105	450	508
120	450	508
150	900	1016
180	918	1034
210	932	1048
240	944	1060
270	1389	1568
300	1404	1583
330	1419	1598
360	1434	1613
390	1687	1913
420	1702	1928
450	1717	1943
480	1737	1963
510	1990	2264
540	2010	2284
570	2025	2299
600	2040	2314
630	2533	2883
660	2548	2898

<i>Continued- EWx NOMINAL BOILER WEIGHTS</i>		
EWx KW	DRY WEIGHT (LBS.)	WET WEIGHT (LBS.)
690	2563	2913
720	2578	2928
750	2831	3228
780	2846	3243
810	2861	3258
840	2881	3278
870	3134	3578
900	3154	3598
930	3169	3613
960	3184	3628
990	3592	4083
1020	3612	4103
1050	3632	4123
1080	3652	4143
1110	3905	4443
1140	3925	4463
1170	3940	4478
1200	3955	4493

Electrical Grounding

Ground the boiler in accordance with NFPA 70 and all applicable local and national electrical codes to ensure personnel safety and system reliability.

Environmental Conditions

Install the boiler indoors in an environment maintained between 32°F (0°C) and 104°F (40°C). Protect the unit from:

- Dripping or sprayed water

- Rain or moisture intrusion
- Airborne dust, dirt, or debris (such as drywall or insulation fibers)

Installation Requirements

Base And Leveling

- Position the boiler on a stable, level, non-combustible foundation capable of supporting the full operating weight.
- Once positioned, ensure it is level and securely fastened to prevent vibration or movement during operation.
- If installation on a combustible surface (e.g., wood) is unavoidable, ensure proper support, leveling, and structural integrity. The boiler base provides a 2-inch minimum clearance from combustible materials.

Location

- Indoor installation only—do not install outdoors or in locations subject to freezing unless in a weather protected shelter with adequate ventilation.
- Avoid areas exposed to corrosive vapors or chemicals.
- Install where leaks will not cause property damage. Provide a floor drain or a plumbed drain pan with slope toward the drain to capture leakage.

Clearances And Access

- Refer to Figure 5 – EWx Series Boiler Dimensions and Clearances for minimum clearances and dimensions.
- Maintain 36 inches of clearance in front of access doors (per NEC). Increase to 48 inches if facing another boiler or conductive wall.
- Provide 24 inches clearance on the water inlet/outlet side for piping and service access.
- Maintain 2 inches of clearance on all other sides (also meeting combustible spacing requirements).
- Allow adequate space for removal of heating elements and service components.

Ventilation

If installed in a room with limited ventilation, provide a ducted supply of filtered air to the lower section of the control cabinet to maintain an internal temperature below 122°F (50°C) during operation.

Figure 5 – EWx Series Boiler Dimensions and Clearances

MODEL	DIMENSIONS (INCHES)							VOLUME (GAL)
	HEIGHT	WIDTH	DEPTH	C-C HEADER	OUTLET TO FLOOR	INLET TO FLOOR	WIDTH INCL. HEADER	
EWx30 - EWx120	43.4	32.5	16.6	22.1	28.8	6.7	41.1	6.9
EWx150 - EWx240	77.7	36.1	22.1	22.1	28.8	6.7	45.2	13.7
EWx270 - EWx600	77.7	36.1	34.5	22.1	28	5.9	43.2	20.5 - 31.8
EWx630 - EWx960	77.7	51.1	34.5	22.1	28	5.9	58.7	41 - 52.2
EWx990 - EWx1200	77.7	64.1	34.5	22.1	28	5.9	73	57.9 - 63.5

EWx30-EWx120 Dimensional and Clearance Drawing

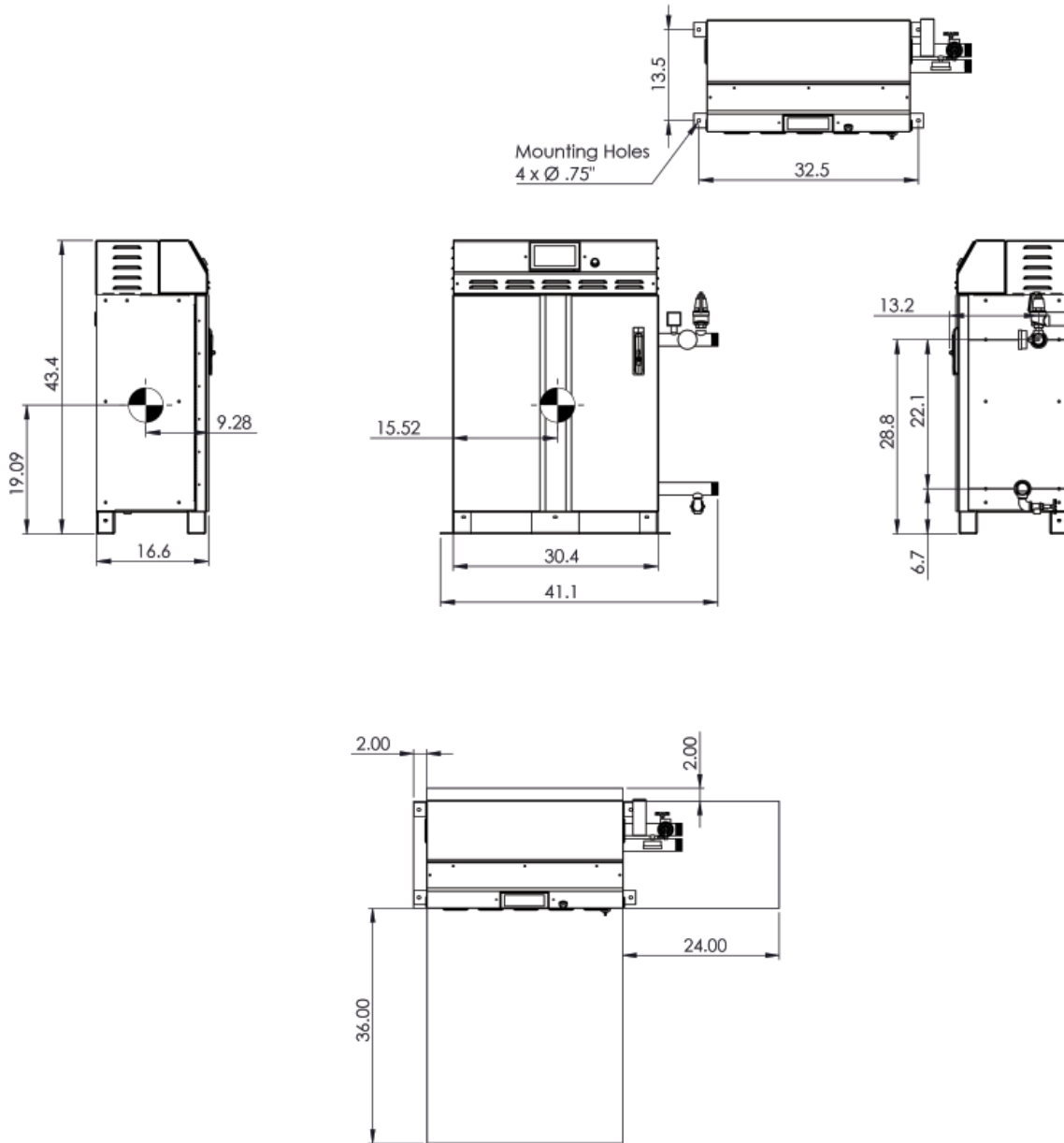

EWx150–EWx240 Dimensional and Clearance Drawing

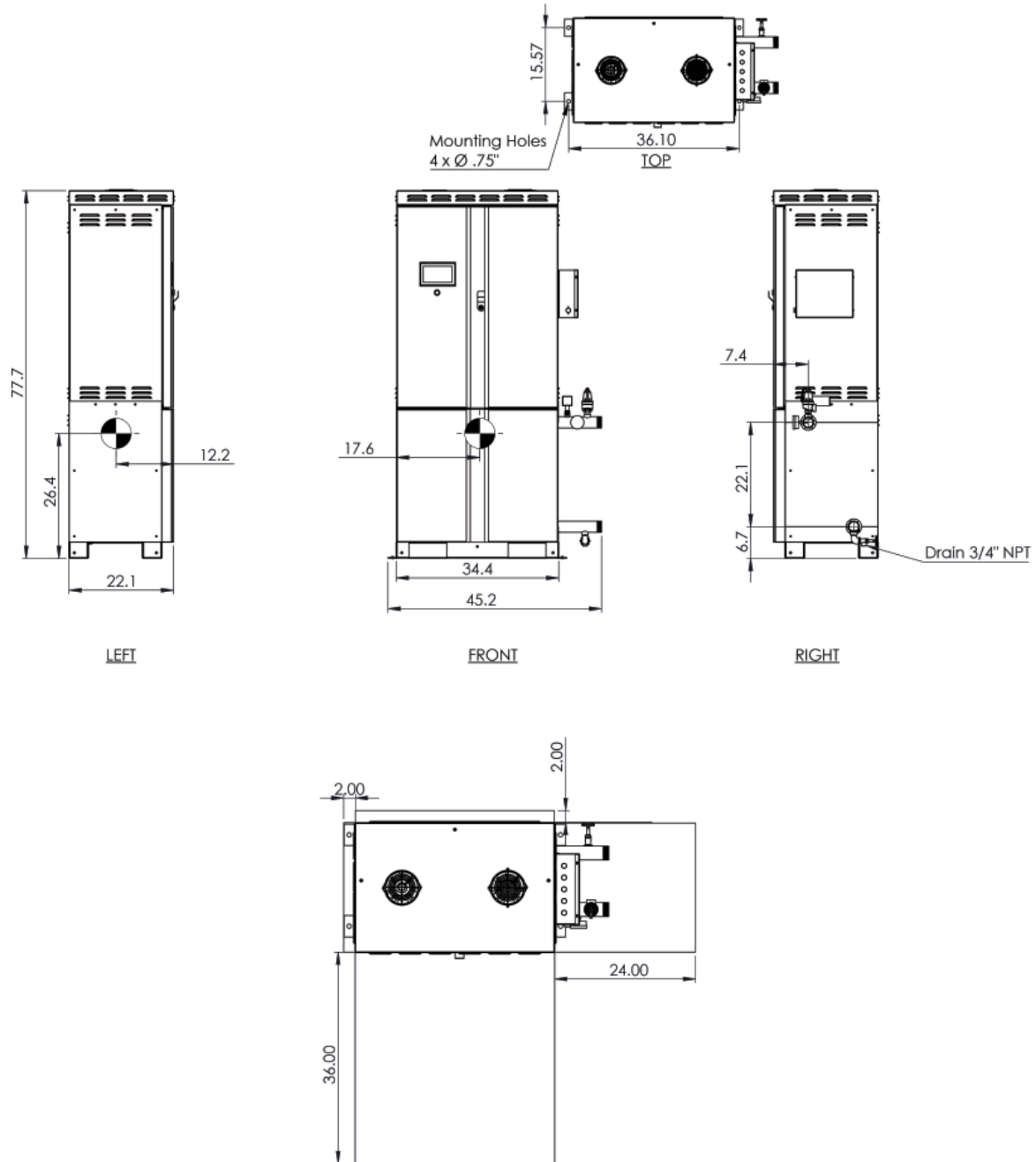

EWx270–EWx600 Dimensional and Clearance Drawing
EXCLUDES EWx510–EWx600 208V, 240V

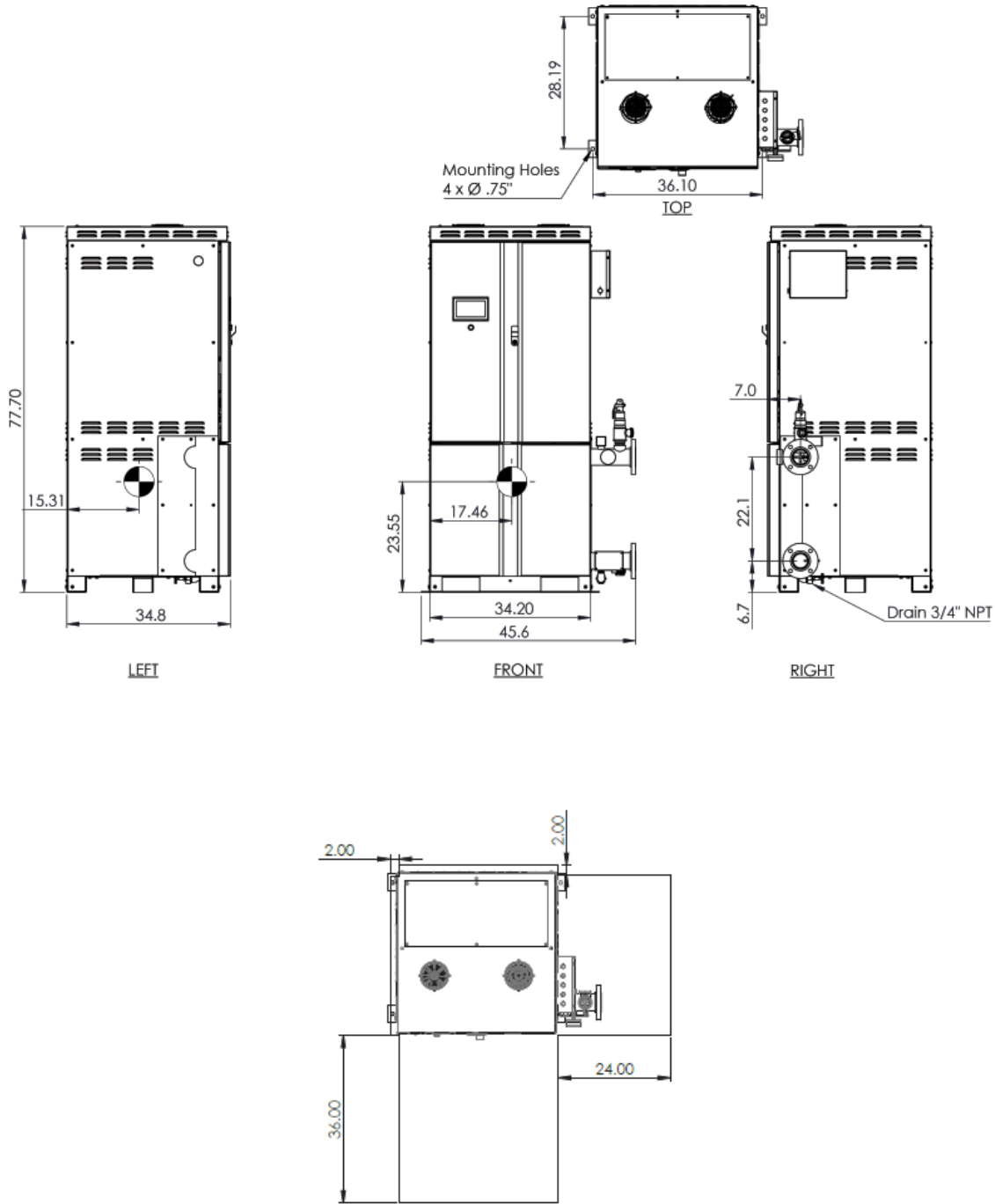

EWx510-EWx600 208V & 240V Dimensional and Clearance Drawing

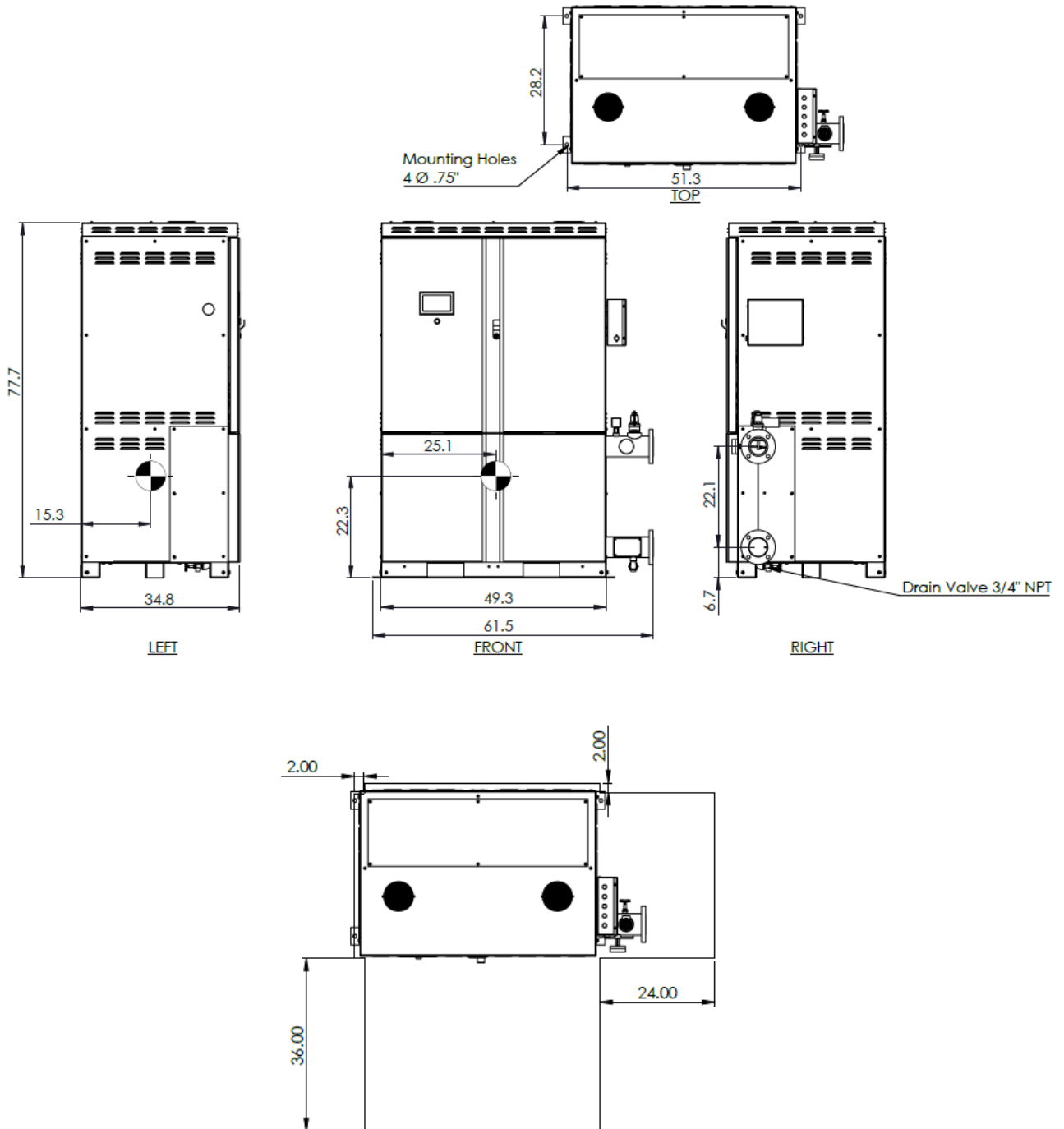

EWx630–EWx960 Dimensional and Clearance Drawing

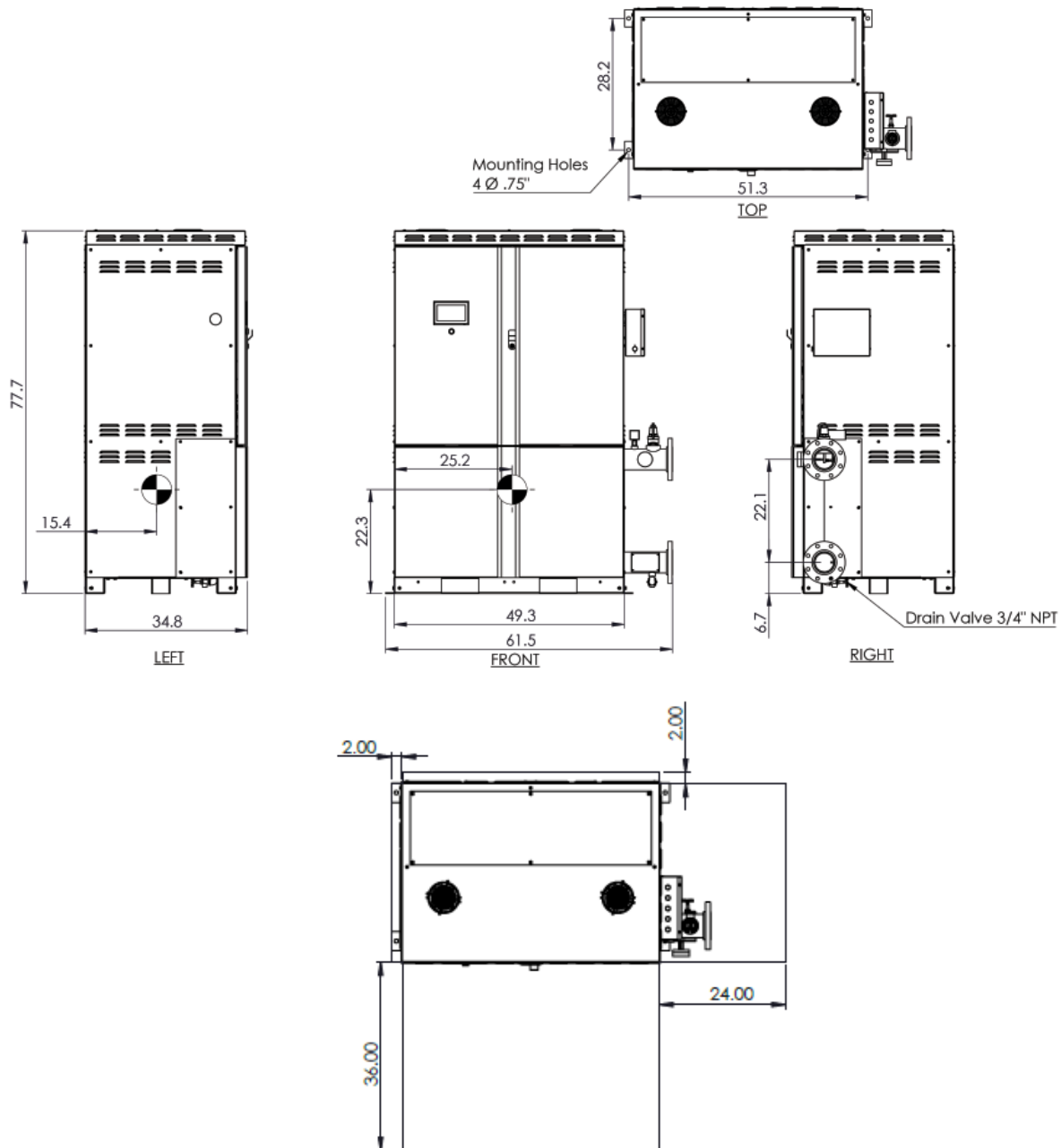

EWx990–EWx1200 Dimensional and Clearance Drawing

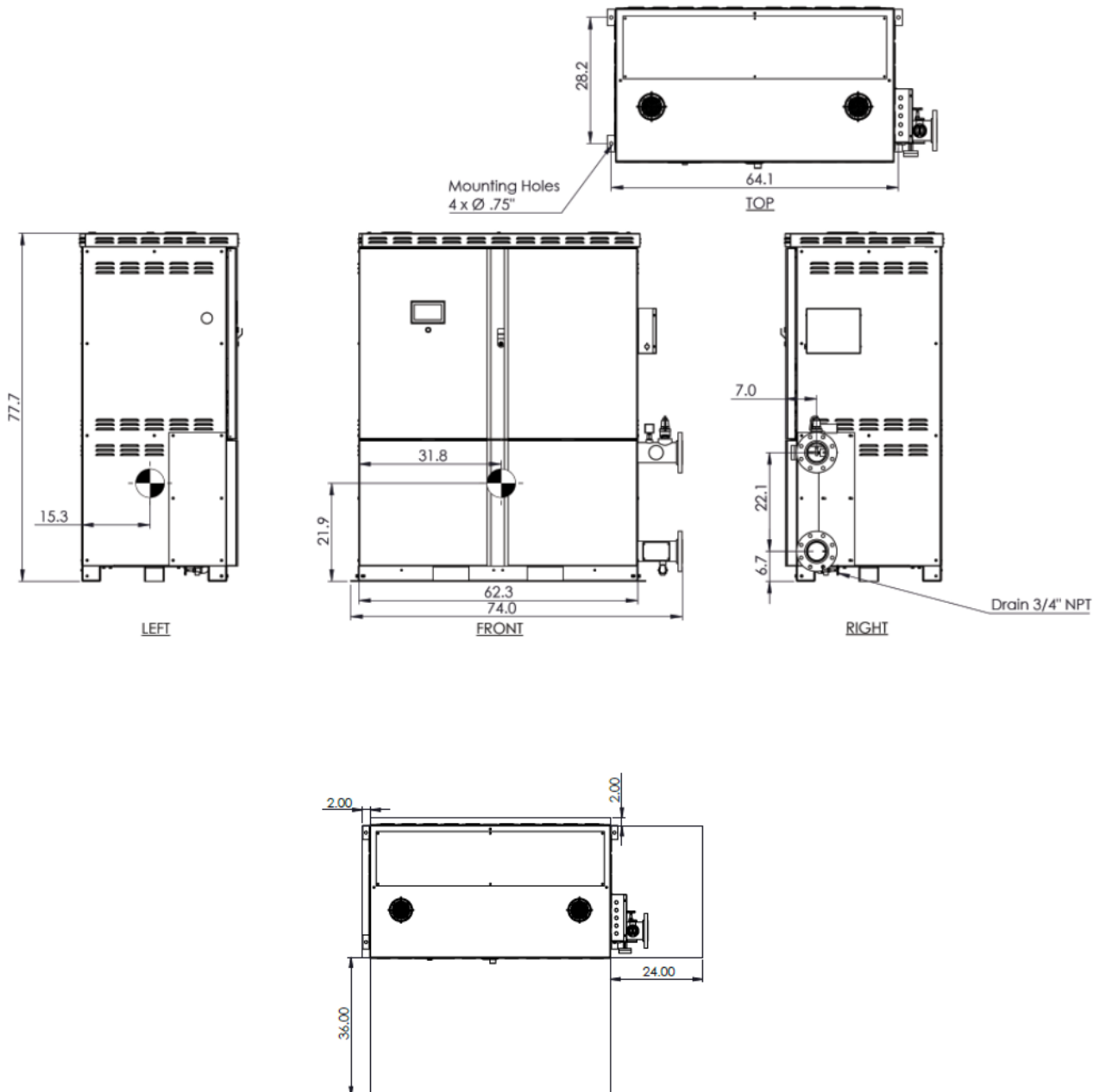

Optional Components

Optional components for the EWx Series Hot Water Boilers include an outdoor air sensor, a header sensor for remote temperature sensing, a flow switch, a control circuit transformer and motorized water flow control valves. These accessories are application-dependent and must be installed and properly wired prior to operating the boiler.

NOTE:

1. *Component images may differ from actual parts based on size and type. Always refer to the latest dimensional drawings to confirm connection details and orientations before installation.*
2. *Do not manually trip the ASME P&T relief valve under any circumstances. Doing so will void the product warranty.*

Outdoor Air Sensor

1. An outdoor temperature sensor (PN 28028) is required only when outdoor air temperature reset functionality is utilized. It is not necessary for constant setpoint operation.
2. Wire the sensor to the appropriate terminals in the I/O Box. Refer to Section xxx for terminal locations.
3. Mount the sensor on the north side of the building where it will measure a representative outdoor temperature. The sensor must be protected from direct sunlight and isolated from heat sources or exhaust from mechanical equipment. If a protective shield is used, it must allow free air circulation.
4. Configure the outdoor reset schedule through the SETUP WIZARD on the boiler controller during system startup.

System Header Sensor

1. If utilized, mount the header sensor (PN 28027) as shown on the piping diagram. It is installed in the system common header between 2 and 10 feet downstream of the last boiler.
2. The header sensor is installed in the supplied well; ensure it is fully inserted into the well.
3. Wire the sensor to the appropriate terminals in the I/O Box. Refer to Section 3, figure 7 for terminal locations.
4. Configure the use of the header sensor through the SETUP WIZARD on the boiler controller during system startup.

Piping Installation and Unit Connections

EWx Series units are designed for a variety of domestic water applications within their rated temperature and pressure limits.

Before making any piping connections, refer to Figure 6 – EWx Series Piping and Installation Diagrams for the correct configuration (single or multiple units, with or without storage tanks).

Drawings are also available at www.sussmanboilers.com for detailed layout specifications.

For special applications or technical assistance, contact your local Sussman Electric Boiler representative or the DHT factory.

PLUMBING REQUIREMENTS



WARNING

ALL PLUMBING CONNECTIONS MUST COMPLY WITH LOCAL REGULATIONS, NATIONAL PLUMBING CODES, AND INDUSTRY STANDARDS. Improper installation may result in equipment damage, water leakage, or personal injury.

INLET AND OUTLET CONNECTIONS

- For single boiler installations, install stop valves on both inlet and outlet connections. This allows draining and cleaning of the boiler without emptying the entire system.
- For multiple boiler installations, stop valves are required on each boiler's inlet and outlet connections.
- Connection orientation:
 - Connect the system return piping to the boiler inlet (bottom connection).
 - Connect the system supply piping to the boiler outlet (top connection).
 - Do not reverse these connections. Reversing flow may result in improper operation or damage to the unit.

Pressure Relief Valve

- Each EWx boiler is equipped with a factory-supplied pressure relief valve to prevent the pressure from exceeding the maximum allowable working pressure (MAWP).
- Connection requirements:
 - Pipe the relief valve outlet to a suitable drain away from equipment, walkways, and personnel.
 - Maintain the full outlet size of the relief valve — do not reduce the discharge pipe diameter.
 - Do not install valves, plugs, or other obstructions in this discharge line. The relief valve must be free to discharge at all times.



WARNING

IMPROPER INSTALLATION OF THE PRESSURE RELIEF DISCHARGE PIPING MAY CAUSE EQUIPMENT DAMAGE OR PERSONAL INJURY.

Drain Piping

- Most jurisdictions prohibit direct discharge from the boiler drain into a sewer system. Verify all local requirements before connecting any drain piping.
- Equip all low points in the system with drain valves.
- Provide individual shutoff and drain valves for each piece of equipment to allow service without draining the entire system.

Circulation Pumps

- Select a circulation pump with an energy head rating greater than the calculated system head at the design flow rate.
- Adjust flow as needed using a globe valve or other appropriate balancing device.

Expansion Tank

- Closed-loop systems require an appropriately sized expansion tank to accommodate thermal expansion and maintain proper system pressure.

Provisions For Maintenance

- Install unions or flanged connections on both the inlet and outlet piping to simplify future maintenance, inspection, or unit replacement.

Insulation

- After completing leak testing, insulate all hot-water piping to conserve energy, reduce heat loss, and protect personnel from burns.

Figure 6 – EWx Series Piping and Installation Diagrams

PRIMARY-SECONDARY SINGLE UNIT

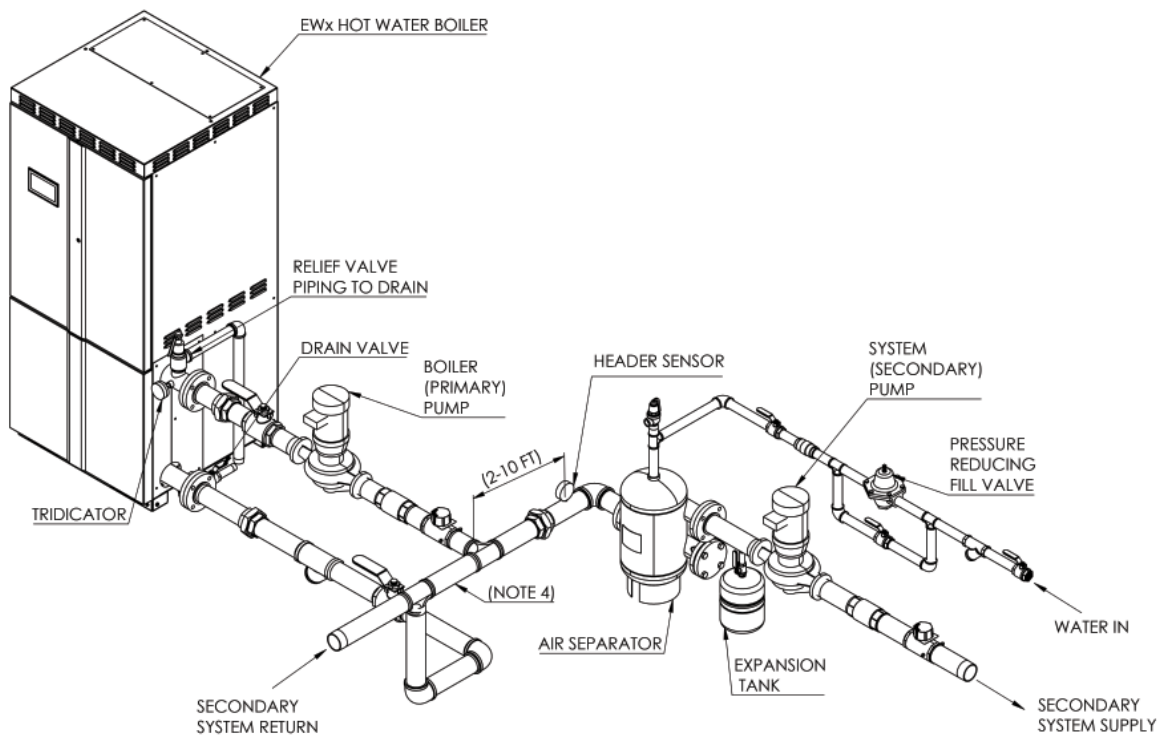

PRIMARY MULTIPLE UNITS

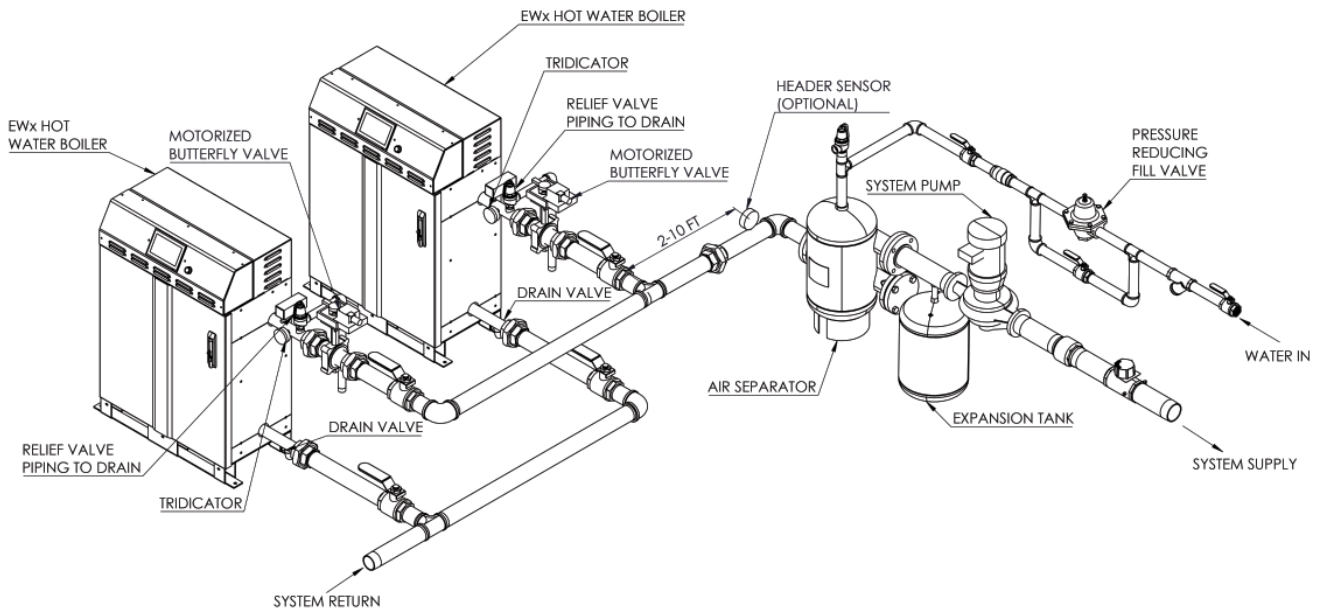

Electrical Wiring

All electrical wiring must be performed by a qualified electrician in accordance with National and Local Electrical Codes.

Each EWx boiler is factory pre-wired and tested prior to shipment to ensure proper functionality.

General Requirements

1. Grounding

Ground the boiler according to National Electrical Code (NEC) requirements to prevent electrical shock hazards.

2. Power Supply and Field Wiring

Field wiring must comply with NEC and local code requirements and follow the wiring diagram supplied with the boiler.

- a. Use properly sized copper conductors only.
- b. Wire size, temperature rating (minimum 90°C), and conductor type are specified adjacent to the field wiring terminals.
- c. Deviation from these requirements may result in unsafe or improper boiler operation.
- d. When wiring the field power supply, follow NFPA 70 (National Electrical Code).

3. *Disconnect Switch*

Install a disconnect switch with circuit breakers or fuses between the main power source and the boiler.

The disconnect must be:

- a. Located near the boiler.
- b. Clearly marked for easy identification and emergency access.

4. *Pump Interlock*

The boiler control circuit and the system pump (supplied by others) must be interlocked to ensure the pump operates whenever the boiler is energized.

5. *Terminal Connections*

With the main power OFF, verify all wiring terminations are tight and torqued to the correct setting. Loose connections can cause arcing, overheating, or carbonization of contacts.

Figure 7 – EWx Series Standard Electrical Wiring Diagrams and Schematics

EWx Electric Water Boilers With 480V Power Voltage

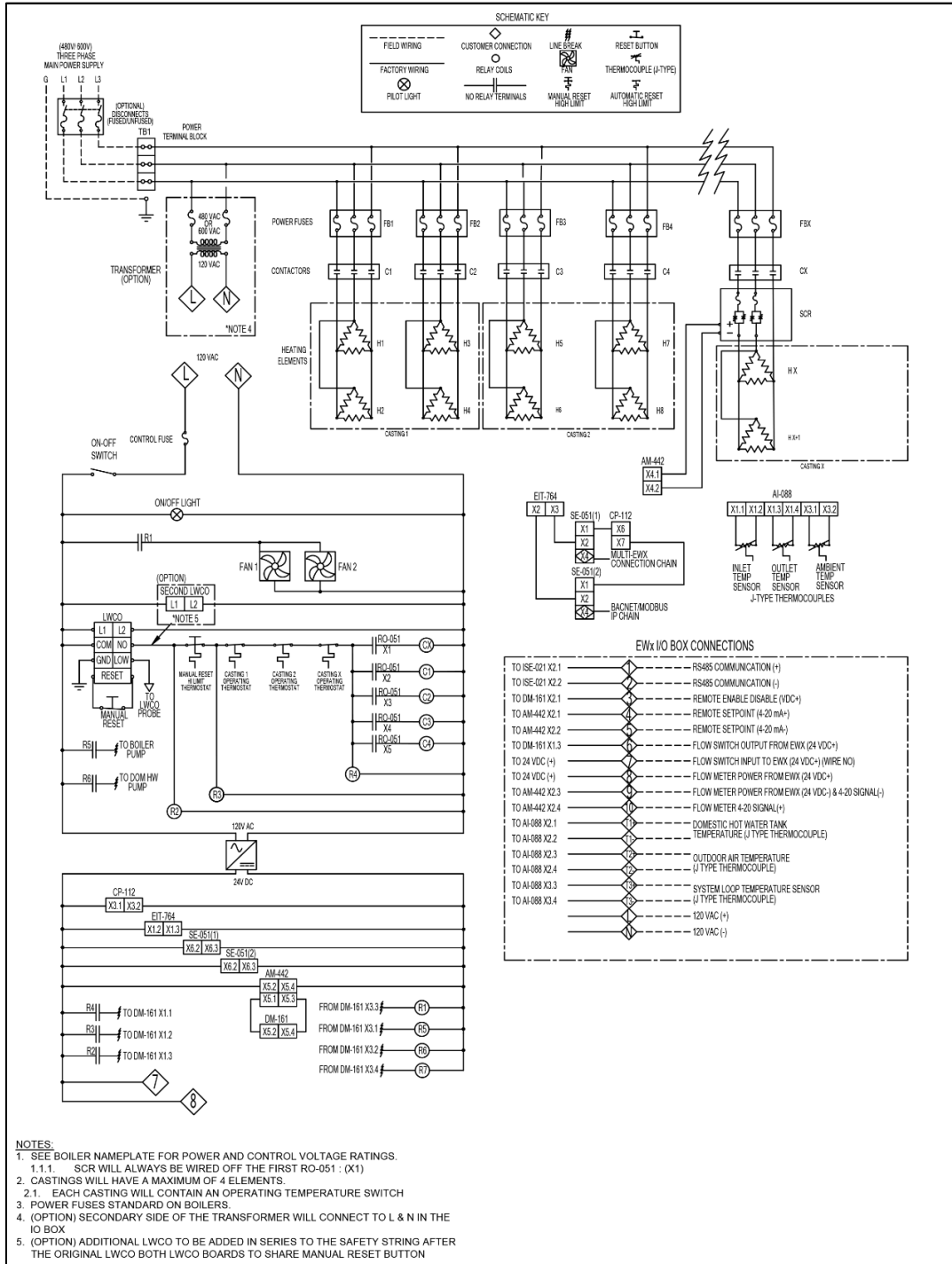

EWx Electric Water Boilers With 208V Power Voltage

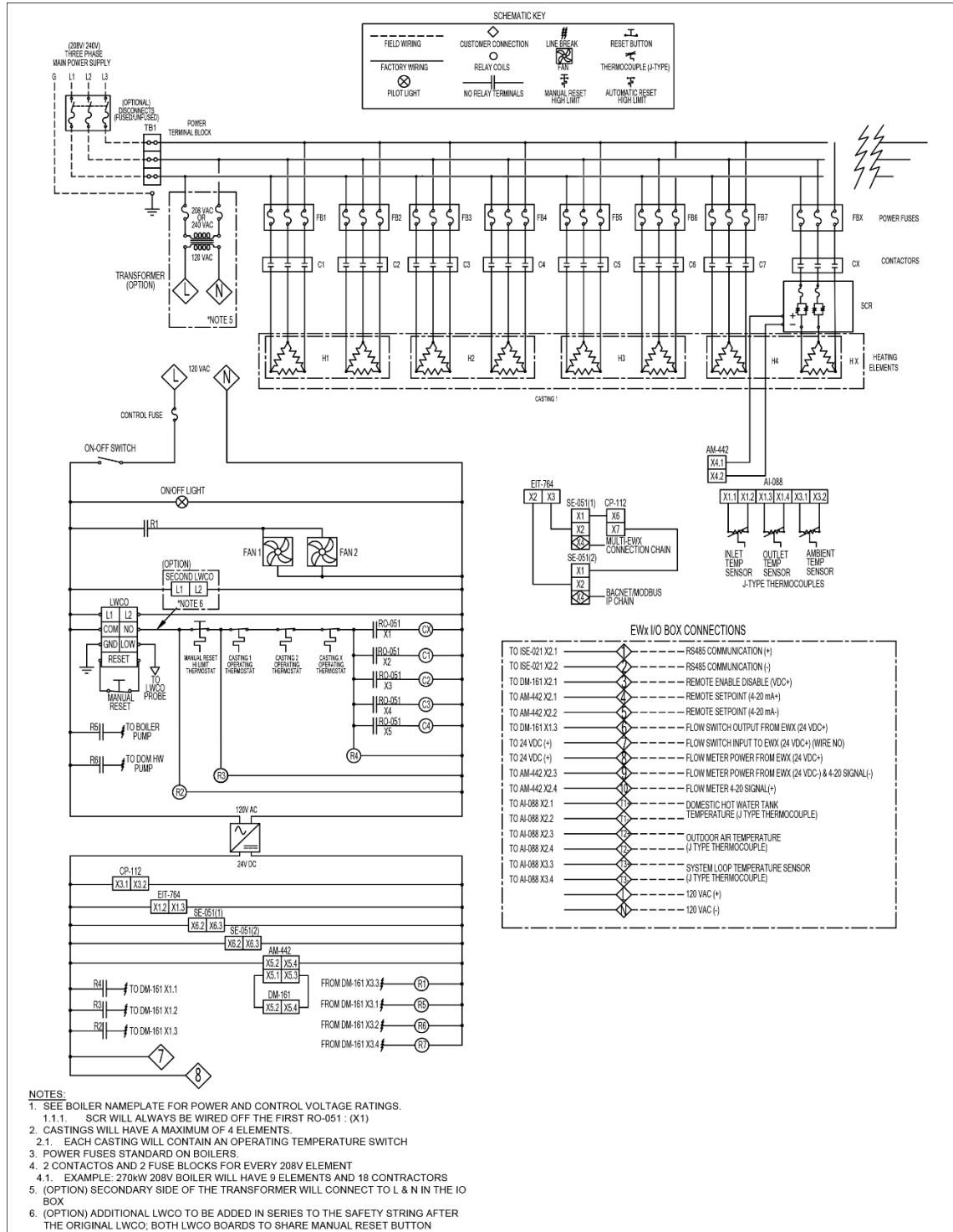

Figure 8- Torque Values

TORQUE VALUES		
Mechanical:		
Element Flange Nuts (5/16"-18, Grade B7)	22 LB-FT	29.8 NM
Electrical:		
Element Terminal Nuts	20 LB-IN	2.26 NM
Contactors, Fuse Blocks, Power Blocks Load Side - #6 AWG Wire	45 LB-IN	60.01 NM
Power Blocks Line Side - #8 AWG Wire	25 LB-IN	2.82 NM
Power Blocks Line Side - #6 AWG & #4 AWG Wire	45 LB-IN	5.08 NM
Power Blocks Line Side - #3 AWG to 3/0 AWG Wire	50 LB-IN	5.65 NM
Power Blocks Line Side - 4/0 AWG to 250 KCMIL Wire	50 LB-IN	5.65 NM
Power Blocks Line Side - 350 KCMIL Wire	50LB-IN	5.65 NM
Power Blocks Line Side - 500 to 1000 KCMIL Wire	50LB-IN	5.65 NM
Ground Blocks Line Side - #8 AWG Wire	25 LB-IN	2.82 NM
Ground Blocks Line Side - #6 AWG & #4 AWG Wire	45 LB-IN	5.08 NM
Ground Blocks Line Side - #3 AWG to #1 AWG Wire	50 LB-IN	5.65 NM



CAUTION

- **Verify that the power supply voltage and phase match the boiler's rated voltage and phase shown on the nameplate.**
 - Incorrect voltage or phase connection may result in component damage or improper boiler operation.



WARNING

SUBSTITUTION OF COMPONENTS OR MODIFICATION OF THE WIRING SYSTEM WILL VOID THE WARRANTY AND MAY RESULT IN HAZARDOUS OPERATING CONDITIONS.



SURGE PROTECTION

- Boilers are susceptible to lightning or surge damage through water line connections. Install an industrial-grade lightning/surge protector at the service entrance per the manufacturer's recommendations.
Consult a qualified contractor or electrical supplier for proper installation.

Power Feed Wiring

The recommended wire size, quantity of power wires per phase, quantity and size of ground wires, Minimum Circuit Ampacity (MCA) and Maximum Over Current Protection are found on the following Power Wire Charts. Select the appropriate power voltage and Short Circuit Current Rating of the boiler to select the correct chart, then select the boiler kW. The chart also has a suggested wiring figure to wire into each boiler power block. The wiring figures can be found after the Power Wiring Charts.

The Full Load Amperage (FLA) and maximum voltage are stamped on the boiler's nameplate.

- Feeders must be sized for 125% of the FLA in accordance with NEC Article 424-3.
- Wiring insulation must be rated 90°C or greater.
- Copper conductors are required for all power connections.
- All power connections are 3-Phase, 3-Wire, except for single-phase units.
- There is no neutral connection; do not wire the unit in a “*wye*” or “*star*” configuration.

**CAUTION**

Do not exceed the maximum voltage listed on the nameplate.

Equipment Grounding Conductors

- Grounding lugs are provided inside the power panel.
- Grounding conductors must be installed and sized in accordance with NEC Article 424-14 and the Power Wiring Charts.

Short Circuit Current Rating (SCCR)

Each EWx is available in 5,000-amp SCCR or 100,000-amp SCR. The wiring installation may differ between the two; review the specific wiring charts and instructions for the specific boiler SCCR.

Overcurrent Protection

Figure 9- Overcurrent Protection Charts

POWER SUPPLY WIRING EWx 208V 3-Phase 5KA SCCR - Copper 90°C

Model No	KW	Full Load Amps	MCA	Max OCPD	No of Wires x Min Wire Size/Phase		Max Wire Size/Phase	# of Ground Wires x Wire Size		Wiring Diagram
EWx30B3	30	84	105	110	1 x	3 AWG	2/0 AWG	1 x	6 AWG	Figure 2
EWx45B3	45	125	157	175	1 x	1/0 AWG	2/0 AWG	1 x	6 AWG	Figure 2
EWx60B3	60	167	209	225	1 x	3/0 AWG	350 MCM	1 x	4 AWG	Figure 2
EWx75B3	75	209	262	300	1 x	250 MCM	350 MCM	1 x	4 AWG	Figure 2
EWx90B3	90	250	313	350	1 x	300 MCM	600 MCM	1 x	3 AWG	Figure 2
EWx105B3	105	292	365	400	1 x	500 MCM	600 MCM	1 x	2 AWG	Figure 2
EWx120B3	120	334	418	450	1 x	500 MCM	600 MCM	1 x	2 AWG	Figure 2
EWx150B3	150	417	522	600	2 x	250 MCM	350 MCM	2 x	4 AWG	Figure 3
EWx180B3	180	500	625	700	2 x	300 MCM	500 MCM	2 x	3 AWG	Figure 3
EWx210B3	210	583	729	800	2 x	500 MCM	500 MCM	2 x	2 AWG	Figure 3
EWx240B3	240	667	834	1000	2 x	500 MCM	600 MCM	2 x	2 AWG	Figure 4
EWx270B3	270	750	938	1000	2 x	4/0 AWG	350 MCM	4 x	4 AWG	Figure 5
EWx300B3	300	833	1042	1200	4 x	250 MCM	350 MCM	4 x	4 AWG	Figure 5
EWx330B3	330	916	1145	1200	4 x	250 MCM	350 MCM	4 x	4 AWG	Figure 5
EWx360B3	360	1000	1250	1600	4 x	300 MCM	500 MCM	4 x	3 AWG	Figure 5
EWx390B3	390	1083	1354	1600	4 x	350 MCM	500 MCM	4 x	3 AWG	Figure 5
EWx420B3	420	1166	1458	1600	4 x	500 MCM	500 MCM	4 x	2 AWG	Figure 5
EWx450B3	450	1250	1563	1600	6 x	250 MCM	350 MCM	6 x	4 AWG	Figure 6
EWx480B3	480	1333	1667	2000	6 x	250 MCM	350 MCM	6 x	4 AWG	Figure 6
EWx510B3	510	1416	1770	2000	6 x	300 MCM	350 MCM	6 x	3 AWG	Figure 6
EWx540B3	540	1499	1874	2000	6 x	300 MCM	500 MCM	6 x	3 AWG	Figure 6
EWx570B3	570	1583	1979	2000	6 x	350 MCM	500 MCM	6 x	3 AWG	Figure 6
EWx600B3	600	1666	2083	2500	6 x	350 MCM	500 MCM	6 x	3 AWG	Figure 6

POWER SUPPLY WIRING EWx 208V 3-Phase 100KA SCCR - Copper 90°C

Model No	KW	Full Load Amps	MCA	Max OCPD	No of Wires x Min Wire Size/Phase	Max Wire Size/Phase	# of Ground Wires x Wire Size	Wiring Diagram
EWx30B3-100kA	30	84	105	110	1 x 3 AWG	2/0 AWG	1 x 6 AWG	Figure 2
EWx45B3-100kA	45	125	157	175	1 x 1/0 AWG	2/0 AWG	1 x 6 AWG	Figure 2
EWx60B3-100kA	60	167	209	225	1 x 3/0 AWG	350 MCM	1 x 4 AWG	Figure 2
EWx75B3-100kA	75	209	262	300	1 x 250 MCM	350 MCM	1 x 4 AWG	Figure 2
EWx90B3-100kA	90	250	313	350	1 x 300 MCM	1000 MCM	1 x 3 AWG	Figure 2
EWx105B3-100kA	105	292	365	400	1 x 500 MCM	1000 MCM	1 x 2 AWG	Figure 2
EWx120B3-100kA	120	334	418	450	1 x 500 MCM	1000 MCM	1 x 2 AWG	Figure 2
EWx150B3-100kA	150	417	522	600	2 x 250 MCM	350 MCM	2 x 4 AWG	Figure 3
EWx180B3-100kA	180	500	625	700	2 x 300 MCM	500 MCM	2 x 3 AWG	Figure 3
EWx210B3-100kA	210	583	729	800	2 x 500 MCM	500 MCM	2 x 2 AWG	Figure 3
EWx240B3-100kA	240	667	834	1000	2 x 500 MCM	1000 MCM	2 x 2 AWG	Figure 4
EWx270B3-100kA	270	750	938	1000	4 x 4/0 AWG	350 MCM	4 x 4 AWG	Figure 5
EWx300B3-100kA	300	833	1042	1200	4 x 250 MCM	350 MCM	4 x 4 AWG	Figure 5
EWx330B3-100kA	330	916	1145	1200	4 x 250 MCM	350 MCM	4 x 4 AWG	Figure 5
EWx360B3-100kA	360	1000	1250	1600	4 x 300 MCM	500 MCM	4 x 3 AWG	Figure 5
EWx390B3-100kA	390	1083	1354	1600	4 x 350 MCM	500 MCM	4 x 3 AWG	Figure 5
EWx420B3-100kA	420	1166	1458	1600	4 x 500 MCM	500 MCM	4 x 2 AWG	Figure 5
EWx450B3-100kA	450	1250	1563	1600	6 x 250 MCM	350 MCM	6 x 4 AWG	Figure 6
EWx480B3-100kA	480	1333	1667	2000	6 x 250 MCM	350 MCM	6 x 4 AWG	Figure 6
EWx510B3-100kA	510	1416	1770	2000	6 x 300 MCM	350 MCM	6 x 3 AWG	Figure 6
EWx540B3-100kA	540	1499	1874	2000	6 x 300 MCM	500 MCM	6 x 3 AWG	Figure 6
EWx570B3-100kA	570	1583	1979	2000	6 x 350 MCM	500 MCM	6 x 3 AWG	Figure 6
EWx600B3-100kA	600	1666	2083	2500	6 x 350 MCM	500 MCM	6 x 3 AWG	Figure 6

POWER SUPPLY WIRING EWx 240V 3-Phase 5KA SCCR - Copper 90°C

Model No	KW	Full Load Amps	MCA	Max OCPD	No of Wires x Min Wire Size/Phase	Max Wire Size/Phase	# of Ground Wires x Wire Size	Wiring Diagram
EWx30C3	30	73	92	100	1 x 4 AWG	2/0 AWG	1 x 8 AWG	Figure 2
EWx45C3	45	109	137	150	1 x 1 AWG	2/0 AWG	1 x 6 AWG	Figure 2
EWx60C3	60	145	182	200	1 x 2/0 AWG	350 MCM	1 x 4 AWG	Figure 2
EWx75C3	75	181	227	250	1 x 4/0 AWG	350 MCM	1 x 4 AWG	Figure 2
EWx90C3	90	217	272	300	1 x 250 MCM	350 MCM	1 x 4 AWG	Figure 2
EWx105C3	105	253	317	350	1 x 300 MM	600 MCM	1 x 3 AWG	Figure 2
EWx120C3	120	289	362	400	1 x 500 MCM	600 MCM	1 x 2 AWG	Figure 2
EWx150C3	150	361	452	500	2 x 4/0 AWG	350 MCM	2 x 4 AWG	Figure 3
EWx180C3	180	434	543	600	2 x 250 MCM	350 MCM	2 x 4 AWG	Figure 3
EWx210C3	210	506	633	700	2 x 300 MCM	500 MCM	2 x 3 AWG	Figure 3

Model No	KW	Full Load Amps	MCA	Max OCPD	No of Wires x Min Wire Size/Phase	Max Wire Size/Phase	# of Ground Wires x Wire Size	Wiring Diagram
EWx240C3	240	578	723	800	2 x 500 MCM	500 MCM	2 x 2 AWG	Figure 3
EWx270C3	270	650	813	1000	2 x 500 MCM	600 MCM	2 x 2 AWG	Figure 4
EWx300C3	300	722	903	1000	4 x 4/0 AWG	350 MCM	4 x 4 AWG	Figure 5
EWx330C3	330	794	993	1000	4 x 4/0 AWG	350 MCM	4 x 4 AWG	Figure 5
EWx360C3	360	867	1084	1200	4 x 250 MCM	350 MCM	4 x 4 AWG	Figure 5
EWx390C3	390	939	1174	1200	4 x 300 MCM	350 MCM	4 x 3 AWG	Figure 5
EWx420C3	420	1011	1264	1600	4 x 300 MCM	500 MCM	4 x 3 AWG	Figure 5
EWx450C3	450	1083	1354	1600	4 x 350 MCM	500 MCM	4 x 3 AWG	Figure 5
EWx480C3	480	1155	1444	1600	4 x 500 MCM	500 MCM	4 x 3 AWG	Figure 5
EWx510C3	510	1227	1534	1600	6 x 4/0 AWG	350 MCM	6 x 4 AWG	Figure 5
EWx540C3	540	1300	1625	2000	6 x 250 MCM	350 MCM	6 x 4 AWG	Figure 5
EWx570C3	570	1372	1715	2000	6 x 250 MCM	350 MCM	6 x 4 AWG	Figure 6
EWx600C3	600	1444	1805	2000	6 x 300 MCM	350 MCM	6 x 3 AWG	Figure 6
EWx30C3	30	73	92	100	1 x 4 AWG	2/0 AWG	1 x 8 AWG	Figure 2
EWx45C3	45	109	137	150	1 x 1 AWG	2/0 AWG	1 x 6 AWG	Figure 2
EWx60C3	60	145	182	200	1 x 2/0 AWG	350 MCM	1 x 4 AWG	Figure 2
EWx75C3	75	181	227	250	1 x 4/0 AWG	350 MCM	1 x 4 AWG	Figure 2
EWx90C3	90	217	272	300	1 x 250 MCM	350 MCM	1 x 4 AWG	Figure 2
EWx105C3	105	253	317	350	1 x 300 MM	600 MCM	1 x 3 AWG	Figure 2
EWx120C3	120	289	362	400	1 x 500 MCM	600 MCM	1 x 2 AWG	Figure 2
EWx150C3	150	361	452	500	2 x 4/0 AWG	350 MCM	2 x 4 AWG	Figure 3
EWx180C3	180	434	543	600	2 x 250 MCM	350 MCM	2 x 4 AWG	Figure 3
EWx210C3	210	506	633	700	2 x 300 MCM	500 MCM	2 x 3 AWG	Figure 3
EWx240C3	240	578	723	800	2 x 500 MCM	500 MCM	2 x 2 AWG	Figure 3
EWx270C3	270	650	813	1000	2 x 500 MCM	600 MCM	2 x 2 AWG	Figure 4
EWx300C3	300	722	903	1000	4 x 4/0 AWG	350 MCM	4 x 4 AWG	Figure 5
EWx330C3	330	794	993	1000	4 x 4/0 AWG	350 MCM	4 x 4 AWG	Figure 5
EWx360C3	360	867	1084	1200	4 x 250 MCM	350 MCM	4 x 4 AWG	Figure 5
EWx390C3	390	939	1174	1200	4 x 300 MCM	350 MCM	4 x 3 AWG	Figure 5
EWx420C3	420	1011	1264	1600	4 x 300 MCM	500 MCM	4 x 3 AWG	Figure 5
EWx450C3	450	1083	1354	1600	4 x 350 MCM	500 MCM	4 x 3 AWG	Figure 5
EWx480C3	480	1155	1444	1600	4 x 500 MCM	500 MCM	4 x 3 AWG	Figure 5
EWx510C3	510	1227	1534	1600	6 x 4/0 AWG	350 MCM	6 x 4 AWG	Figure 5
EWx540C3	540	1300	1625	2000	6 x 250 MCM	350 MCM	6 x 4 AWG	Figure 5
EWx570C3	570	1372	1715	2000	6 x 250 MCM	350 MCM	6 x 4 AWG	Figure 6
EWx600C3	600	1444	1805	2000	6 x 300 MCM	350 MCM	6 x 3 AWG	Figure 6

POWER SUPPLY WIRING EWx 240V 3-Phase 100KA SCCR - Copper 90°C

Model No	KW	Full Load Amps	MCA	Max OCPD	No of Wires x Min Wire Size/Phase	Max Wire Size/Phase	# of Ground Wires x Wire Size	Wiring Diagram
EWx30C3-100kA	30	73	92	100	1 x 4 AWG	2/0 AWG	1 x 8 AWG	Figure 2
EWx45C3-100kA	45	109	137	150	1 x 1 AWG	2/0 AWG	1 x 6 AWG	Figure 2
EWx60C3-100kA	60	145	182	200	1 x 2/0 AWG	350 MCM	1 x 4 AWG	Figure 2
EWx75C3-100kA	75	181	227	250	1 x 4/0 AWG	350 MCM	1 x 4 AWG	Figure 2
EWx90C3-100kA	90	217	272	300	1 x 250 MCM	350 MCM	1 x 4 AWG	Figure 2
EWx105C3-100kA	105	253	317	350	1 x 300 MM	1000 MCM	1 x 3 AWG	Figure 2
EWx120C3-100kA	120	289	362	400	1 x 500 MCM	1000 MCM	1 x 2 AWG	Figure 2
EWx150C3-100kA	150	361	452	500	2 x 4/0 AWG	350 MCM	2 x 4 AWG	Figure 3
EWx180C3-100kA	180	434	543	600	2 x 250 MCM	350 MCM	2 x 3 AWG	Figure 3
EWx210C3-100kA	210	506	633	700	2 x 300 MCM	500 MCM	2 x 2 AWG	Figure 3
EWx240C3-100kA	240	578	723	800	2 x 500 MCM	500 MCM	2 x 2 AWG	Figure 3
EWx270C3-100kA	270	650	813	1000	2 x 500 MCM	1000 MCM	2 x 4 AWG	Figure 4
EWx300C3-100kA	300	722	903	1000	4 x 4/0 AWG	350 MCM	4 x 4 AWG	Figure 5
EWx330C3-100kA	330	794	993	1000	4 x 4/0 AWG	350 MCM	4 x 4 AWG	Figure 5
EWx360C3-100kA	360	867	1084	1200	4 x 250 MCM	350 MCM	4 x 3 AWG	Figure 5
EWx390C3-100kA	390	939	1174	1200	4 x 300 MCM	350 MCM	4 x 3 AWG	Figure 5
EWx420C3-100kA	420	1011	1264	1600	4 x 300 MCM	500 MCM	4 x 2 AWG	Figure 5
EWx450C3-100kA	450	1083	1354	1600	4 x 350 MCM	500 MCM	6 x 4 AWG	Figure 5
EWx480C3-100kA	480	1155	1444	1600	4 x 500 MCM	500 MCM	6 x 4 AWG	Figure 5

Model No	KW	Full Load Amps	MCA	Max OCPD	No of Wires x Min Wire Size/Phase	Max Wire Size/Phase	# of Ground Wires x Wire Size	Wiring Diagram
EWx510C3-100kA	510	1227	1534	1600	6 x 4/0 AWG	350 MCM	6 x 3 AWG	Figure 5
EWx540C3-100kA	540	1300	1625	2000	6 x 250 MCM	350 MCM	6 x 3 AWG	Figure 5
EWx570C3-100kA	570	1372	1715	2000	6 x 250 MCM	350 MCM	6 x 3 AWG	Figure 6
EWx600C3-100kA	600	1444	1805	2000	6 x 300 MCM	350 MCM	6 x 3 AWG	Figure 6
EWx30C3-100kA	30	73	92	100	1 x 4 AWG	2/0 AWG	1 x 8 AWG	Figure 2
EWx45C3-100kA	45	109	137	150	1 x 1 AWG	2/0 AWG	1 x 6 AWG	Figure 2
EWx60C3-100kA	60	145	182	200	1 x 2/0 AWG	350 MCM	1 x 4 AWG	Figure 2
EWx75C3-100kA	75	181	227	250	1 x 4/0 AWG	350 MCM	1 x 4 AWG	Figure 2
EWx90C3-100kA	90	217	272	300	1 x 250 MCM	350 MCM	1 x 4 AWG	Figure 2
EWx105C3-100kA	105	253	317	350	1 x 300 MM	1000 MCM	1 x 3 AWG	Figure 2
EWx120C3-100kA	120	289	362	400	1 x 500 MCM	1000 MCM	1 x 2 AWG	Figure 2
EWx150C3-100kA	150	361	452	500	2 x 4/0 AWG	350 MCM	2 x 4 AWG	Figure 3
EWx180C3-100kA	180	434	543	600	2 x 250 MCM	350 MCM	2 x 3 AWG	Figure 3
EWx210C3-100kA	210	506	633	700	2 x 300 MCM	500 MCM	2 x 2 AWG	Figure 3
EWx240C3-100kA	240	578	723	800	2 x 500 MCM	500 MCM	2 x 2 AWG	Figure 3
EWx270C3-100kA	270	650	813	1000	2 x 500 MCM	1000 MCM	2 x 4 AWG	Figure 4
EWx300C3-100kA	300	722	903	1000	4 x 4/0 AWG	350 MCM	4 x 4 AWG	Figure 5
EWx330C3-100kA	330	794	993	1000	4 x 4/0 AWG	350 MCM	4 x 4 AWG	Figure 5
EWx360C3-100kA	360	867	1084	1200	4 x 250 MCM	350 MCM	4 x 3 AWG	Figure 5
EWx390C3-100kA	390	939	1174	1200	4 x 300 MCM	350 MCM	4 x 3 AWG	Figure 5

Model No	KW	Full Load Amps	MCA	Max OCPD	No of Wires x Min Wire Size/Phase	Max Wire Size/Phase	# of Ground Wires x Wire Size	Wiring Diagram
EWx420C3-100kA	420	1011	1264	1600	4 x 300 MCM	500 MCM	4 x 2 AWG	Figure 5
EWx450C3-100kA	450	1083	1354	1600	4 x 350 MCM	500 MCM	6 x 4 AWG	Figure 5
EWx480C3-100kA	480	1155	1444	1600	4 x 500 MCM	500 MCM	6 x 4 AWG	Figure 5
EWx510C3-100kA	510	1227	1534	1600	6 x 4/0 AWG	350 MCM	6 x 3 AWG	Figure 5
EWx540C3-100kA	540	1300	1625	2000	6 x 250 MCM	350 MCM	6 x 3 AWG	Figure 5
EWx570C3-100kA	570	1372	1715	2000	6 x 250 MCM	350 MCM	6 x 3 AWG	Figure 6
EWx600C3-100kA	600	1444	1805	2000	6 x 300 MCM	350 MCM	6 x 3 AWG	Figure 6

POWER SUPPLY WIRING EWx 480V 3-Phase 5KA SCCR - Copper 90°C

Model No	KW	Full Load Amps	MCA	Max OCPD	No of Wires x Min Wire Size/Phase	Max Wire Size/Phase	# of Ground Wires x Wire Size	Wiring Diagram
EWx30F3	30	37	47	50	1 x 8 AWG	2/0 AWG	1 x 10 AWG	Figure 1
EWx45F3	45	55	69	70	1 x 6 AWG	2/0 AWG	1 x 8 AWG	Figure 1
EWx60F3	60	73	92	100	1 x 4 AWG	2/0 AWG	1 x 8 AWG	Figure 1
EWx75F3	75	91	114	120	1 x 3 AWG	2/0 AWG	1 x 6 AWG	Figure 2
EWx90F3	90	109	137	150	1 x 1 AWG	2/0 AWG	1 x 6 AWG	Figure 2
EWx105F3	105	127	159	175	1 x 1/0 AWG	2/0 AWG	1 x 6 AWG	Figure 2
EWx120F3	120	145	182	200	1 x 2/0 AWG	350 MCM	1 x 4 AWG	Figure 2
EWx150F3	150	181	227	250	1 x 4/0 AWG	350 MCM	1 x 4 AWG	Figure 2
EWx180F3	180	217	272	300	1 x 250 MCM	350 MCM	1 x 4 AWG	Figure 2
EWx210F3	210	253	317	350	1 x 300 MCM	600 MCM	1 x 3 AWG	Figure 2
EWx240F3	240	289	362	400	1 x 500 MCM	600 MCM	1 x 2 AWG	Figure 2
EWx270F3	270	325	407	450	1 x 500 MCM	600 MCM	1 x 2 AWG	Figure 2
EWx300F3	300	361	452	500	2 x 4/0 AWG	350 MCM	2 x 4 AWG	Figure 3
EWx330F3	330	397	497	500	2 x 4/0 AWG	350 MCM	2 x 4 AWG	Figure 3
EWx360F3	360	434	543	600	2 x 250 MCM	350 MCM	2 x 4 AWG	Figure 3
EWx390F3	390	470	588	600	2 x 300 MCM	350 MCM	2 x 3 AWG	Figure 3
EWx420F3	420	506	633	700	2 x 300 MCM	500 MCM	2 x 3 AWG	Figure 3
EWx450F3	450	542	678	700	2 x 350 MCM	500 MCM	2 x 3 AWG	Figure 3
EWx480F3	480	578	723	800	2 x 500 MCM	500 MCM	2 x 2 AWG	Figure 3
EWx510F3	510	614	768	800	2 x 500 MCM	600 MCM	2 x 2 AWG	Figure 4

Model No	KW	Full Load Amps	MCA	Max OCPD	No of Wires x Min Wire Size/Phase		Max Wire Size/Phase	# of Ground Wires x Wire Size		Wiring Diagram
EWx540F3	540	650	813	1000	2 x	500 MCM	600 MCM	2 x	2 AWG	Figure 4
EWx570F3	570	686	858	1000	2 x	500 MCM	1000 MCM	2 x	2 AWG	Figure 4
EWx600F3	600	722	903	1000	4 x	4/0 AWG	350 MCM	4 x	4 AWG	Figure 5
EWx630F3	630	758	948	1000	4 x	4/0 AWG	350 MCM	4 x	4 AWG	Figure 5
EWx660F3	660	794	993	1000	4 x	4/0 AWG	350 MCM	4 x	4 AWG	Figure 5
EWx690F3	690	830	1038	1200	4 x	4/0 AWG	350 MCM	4 x	4 AWG	Figure 5
EWx720F3	720	867	1084	1200	4 x	250 MCM	350 MCM	4 x	4 AWG	Figure 5
EWx750F3	750	903	1129	1200	4 x	250 MCM	350 MCM	4 x	4 AWG	Figure 5
EWx780F3	780	939	1174	1200	4 x	300 MCM	350 MCM	4 x	3 AWG	Figure 5
EWx810F3	810	975	1219	1600	4 x	300 MCM	350 MCM	4 x	3 AWG	Figure 5
EWx840F3	840	1011	1264	1600	4 x	300 MCM	500 MCM	4 x	3 AWG	Figure 5
EWx870F3	870	1047	1309	1600	4 x	350 MCM	500 MCM	4 x	3 AWG	Figure 5
EWx900F3	900	1083	1354	1600	4 x	350 MCM	500 MCM	4 x	3 AWG	Figure 5
EWx930F3	930	1119	1399	1600	4 x	350 MCM	500 MCM	4 x	3 AWG	Figure 5
EWx960F3	960	1155	1444	1600	4 x	500 MCM	500 MCM	4 x	2 AWG	Figure 5
EWx990F3	990	1191	1489	1600	4 x	500 MCM	500 MCM	4 x	2 AWG	Figure 5
EWx1020F3	1020	1227	1534	1600	6 x	4/0 AWG	350 MCM	6 x	4 AWG	Figure 6
EWx1050F3	1050	1263	1579	1600	6 x	250 MCM	350 MCM	6 x	4 AWG	Figure 6
EWx1080F3	1080	1300	1625	2000	6 x	250 MCM	350 MCM	6 x	4 AWG	Figure 6
EWx1110F3	1110	1336	1670	2000	6 x	250 MCM	350 MCM	6 x	4 AWG	Figure 6
EWx1140F3	1140	1372	1715	2000	6 x	250 MCM	350 MCM	6 x	4 AWG	Figure 6
EWx1170F3	1170	1408	1760	2000	6 x	300 MCM	350 MCM	6 x	3 AWG	Figure 6
EWx1200F3	1200	1444	1805	2000	6 x	300 MCM	350 MCM	6 x	3 AWG	Figure 6

POWER SUPPLY WIRING EWx 480V 3-Phase 100KA SCCR - Copper 90°C

Model No	KW	Full Load Amps	MCA	Max OCPD	No of Wires x Min Wire Size/Phase	Max Wire Size/Phase	# of Ground Wires x Wire Size	Wiring Diagram
EWx30F3-100kA	30	37	47	50	1 x 8 AWG	2/0 AWG	1 x 10 AWG	Figure 1
EWx45F3-100kA	45	55	69	70	1 x 6 AWG	2/0 AWG	1 x 8 AWG	Figure 1
EWx60F3-100kA	60	73	92	100	1 x 4 AWG	2/0 AWG	1 x 8 AWG	Figure 1
EWx75F3-100kA	75	91	114	120	1 x 3 AWG	2/0 AWG	1 x 6 AWG	Figure 2
EWx90F3-100kA	90	109	137	150	1 x 1 AWG	2/0 AWG	1 x 6 AWG	Figure 2
EWx105F3-100kA	105	127	159	175	1 x 1/0 AWG	2/0 AWG	1 x 6 AWG	Figure 2
EWx120F3-100kA	120	145	182	200	1 x 2/0 AWG	350 MCM	1 x 4 AWG	Figure 2
EWx150F3-100kA	150	181	227	250	1 x 4/0 AWG	350 MCM	1 x 4 AWG	Figure 2
EWx180F3-100kA	180	217	272	300	1 x 250 MCM	350 MCM	1 x 4 AWG	Figure 2
EWx210F3-100kA	210	253	317	350	1 x 300 MCM	1000 MCM	1 x 3 AWG	Figure 2
EWx240F3-100kA	240	289	362	400	1 x 500 MCM	1000 MCM	1 x 2 AWG	Figure 2
EWx270F3-100kA	270	325	407	450	1 x 500 MCM	1000 MCM	1 x 2 AWG	Figure 2
EWx300F3-100kA	300	361	452	500	2 x 4/0 AWG	350 MCM	2 x 4 AWG	Figure 3
EWx330F3-100kA	330	397	497	500	2 x 4/0 AWG	350 MCM	2 x 4 AWG	Figure 3
EWx360F3-100kA	360	434	543	600	2 x 250 MCM	350 MCM	2 x 4 AWG	Figure 3
EWx390F3-100kA	390	470	588	600	2 x 300 MCM	350 MCM	2 x 3 AWG	Figure 3
EWx420F3-100kA	420	506	633	700	2 x 300 MCM	500 MCM	2 x 3 AWG	Figure 3
EWx450F3-100kA	450	542	678	700	2 x 350 MCM	500 MCM	2 x 3 AWG	Figure 3
EWx480F3-100kA	480	578	723	800	2 x 500 MCM	500 MCM	2 x 2 AWG	Figure 3

Model No	KW	Full Load Amps	MCA	Max OCPD	No of Wires x Min Wire Size/Phase		Max Wire Size/Phase	# of Ground Wires x Wire Size		Wiring Diagram
EWx510F3-100kA	510	614	768	800	2 x	500 MCM	1000 MCM	2 x	2 AWG	Figure 4
EWx540F3-100kA	540	650	813	1000	2 x	500 MCM	1000 MCM	2 x	2 AWG	Figure 4
EWx570F3-100kA	570	686	858	1000	2 x	500 MCM	1000 MCM	2 x	2 AWG	Figure 4
EWx600F3-100kA	600	722	903	1000	4 x	4/0 AWG	350 MCM	4 x	4 AWG	Figure 5
EWx630F3-100kA	630	758	948	1000	4 x	4/0 AWG	350 MCM	4 x	4 AWG	Figure 5
EWx660F3-100kA	660	794	993	1000	4 x	4/0 AWG	350 MCM	4 x	4 AWG	Figure 5
EWx690F3-100kA	690	830	1038	1200	4 x	4/0 AWG	350 MCM	4 x	4 AWG	Figure 5
EWx720F3-100kA	720	867	1084	1200	4 x	250 MCM	350 MCM	4 x	4 AWG	Figure 5
EWx750F3-100kA	750	903	1129	1200	4 x	250 MCM	350 MCM	4 x	4 AWG	Figure 5
EWx780F3-100kA	780	939	1174	1200	4 x	300 MCM	350 MCM	4 x	3 AWG	Figure 5
EWx810F3-100kA	810	975	1219	1600	4 x	300 MCM	350 MCM	4 x	3 AWG	Figure 5
EWx840F3-100kA	840	1011	1264	1600	4 x	300 MCM	500 MCM	4 x	3 AWG	Figure 5
EWx870F3-100kA	870	1047	1309	1600	4 x	350 MCM	500 MCM	4 x	3 AWG	Figure 5
EWx900F3-100kA	900	1083	1354	1600	4 x	350 MCM	500 MCM	4 x	3 AWG	Figure 5
EWx930F3-100kA	930	1119	1399	1600	4 x	350 MCM	500 MCM	4 x	3 AWG	Figure 5
EWx960F3-100kA	960	1155	1444	1600	4 x	500 MCM	500 MCM	4 x	2 AWG	Figure 5
EWx990F3-100kA	990	1191	1489	1600	4 x	500 MCM	500 MCM	4 x	2 AWG	Figure 5
EWx1020F3-100kA	1020	1227	1534	1600	6 x	4/0 AWG	350 MCM	6 x	4 AWG	Figure 6
EWx1050F3-100kA	1050	1263	1579	1600	6 x	250 MCM	350 MCM	6 x	4 AWG	Figure 6
EWx1080F3-100kA	1080	1300	1625	2000	6 x	250 MCM	350 MCM	6 x	4 AWG	Figure 6

Model No	KW	Full Load Amps	MCA	Max OCPD	No of Wires x Min Wire Size/Phase		Max Wire Size/Phase	# of Ground Wires x Wire Size		Wiring Diagram
EWx1110F3-100kA	1110	1336	1670	2000	6 x	250 MCM	350 MCM	6 x	4 AWG	Figure 6
EWx1140F3-100kA	1140	1372	1715	2000	6 x	250 MCM	350 MCM	6 x	4 AWG	Figure 6
EWx1170F3-100kA	1170	1408	1760	2000	6 x	300 MCM	350 MCM	6 x	3 AWG	Figure 6
EWx1200F3-100kA	1200	1444	1805	2000	6 x	300 MCM	350 MCM	6 x	3 AWG	Figure 6

POWER SUPPLY WIRING EWx 600V 3-Phase 5KA SCCR - Copper 90°C

Model No	KW	Full Load Amps	MCA	Max OCPD	No of Wires x Min Wire Size/Phase		Max Wire Size/Phase	# of Ground Wires x Wire Size		Wiring Diagram
EWx30G3	30	29	37	40	1 x	10 AWG	2/0 AWG	1 x	10 AWG	Figure 1
EWx45G3	45	44	55	60	1 x	8 AWG	2/0 AWG	1 x	10 AWG	Figure 1
EWx60G3	60	58	73	80	1 x	6 AWG	2/0 AWG	1 x	8 AWG	Figure 1
EWx75G3	75	73	92	100	1 x	4 AWG	2/0 AWG	1 x	8 AWG	Figure 2
EWx90G3	90	87	109	110	1 x	3 AWG	2/0 AWG	1 x	6 AWG	Figure 2
EWx105G3	105	102	128	150	1 x	2 AWG	2/0 AWG	1 x	6 AWG	Figure 2
EWx120G3	120	116	145	150	1 x	1 AWG	2/0 AWG	1 x	6 AWG	Figure 2
EWx150G3	150	145	182	200	1 x	2/0 AWG	350 MCM	1 x	4 AWG	Figure 2
EWx180G3	180	174	218	225	1 x	3/0 AWG	350 MCM	1 x	4 AWG	Figure 2
EWx210G3	210	203	254	300	1 x	4/0 AWG	350 MCM	1 x	4 AWG	Figure 2
EWx240G3	240	231	289	300	1 x	250 MCM	350 MCM	1 x	4 AWG	Figure 2
EWx270G3	270	260	325	350	1 x	350 MCM	600 MCM	1 x	3 AWG	Figure 2
EWx300G3	300	289	362	400	1 x	500 MCM	600 MCM	1 x	2 AWG	Figure 2
EWx330G3	330	318	398	400	1 x	500 MCM	600 MCM	1 x	2 AWG	Figure 2
EWx360G3	360	347	434	450	2 x	3/0 AWG	350 MCM	2 x	4 AWG	Figure 3
EWx390G3	390	376	470	500	2 x	4/0 AWG	350 MCM	2 x	4 AWG	Figure 3
EWx420G3	420	405	507	600	2 x	4/0 AWG	350 MCM	2 x	4 AWG	Figure 3
EWx450G3	450	434	543	600	2 x	250 MCM	350 MCM	2 x	4 AWG	Figure 3
EWx480G3	480	462	578	600	2 x	250 MCM	350 MCM	2 x	4 AWG	Figure 3
EWx510G3	510	491	614	700	2 x	300 MCM	350 MCM	2 x	3 AWG	Figure 3
EWx540G3	540	520	650	700	2 x	350 MCM	500 MCM	2 x	3 AWG	Figure 3
EWx570G3	570	549	687	700	2 x	350 MCM	500 MCM	2 x	3 AWG	Figure 3
EWx600G3	600	578	723	800	2 x	500 MCM	500 MCM	2 x	2 AWG	Figure 3
EWx630G3	630	607	759	800	2 x	500 MCM	500 MCM	2 x	2 AWG	Figure 3

Model No	KW	Full Load Amps	MCA	Max OCPD	No of Wires x Min Wire Size/Phase	Max Wire Size/Phase	# of Ground Wires x Wire Size	Wiring Diagram
EWx660G3	660	636	795	800	2 x 500 MCM	600 MCM	2 x 2 AWG	Figure 4
EWx690G3	690	664	830	1000	2 x 500 MCM	600 MCM	2 x 2 AWG	Figure 4
EWx720G3	720	693	867	1000	4 x 3/0 AWG	350 MCM	4 x 4 AWG	Figure 5
EWx750G3	750	722	903	1000	4 x 4/0 AWG	350 MCM	4 x 4 AWG	Figure 5
EWx780G3	780	751	939	1000	4 x 4/0 AWG	350 MCM	4 x 4 AWG	Figure 5
EWx810G3	810	780	975	1000	4 x 4/0 AWG	350 MCM	4 x 4 AWG	Figure 5
EWx840G3	840	809	1012	1200	4 x 4/0 AWG	350 MCM	4 x 4 AWG	Figure 5
EWx870G3	870	838	1048	1200	4 x 250 MCM	350 MCM	4 x 4 AWG	Figure 5
EWx900G3	900	867	1084	1200	4 x 250 MCM	350 MCM	4 x 4 AWG	Figure 5
EWx930G3	930	895	1119	1200	4 x 250 MCM	350 MCM	4 x 4 AWG	Figure 5
EWx960G3	960	924	1155	1200	4 x 250 MCM	350 MCM	4 x 4 AWG	Figure 5
EWx990G3	990	953	1192	1200	4 x 300 MCM	350 MCM	4 x 4 AWG	Figure 5
EWx1020G3	1020	982	1228	1600	4 x 300 MCM	350 MCM	4 x 3 AWG	Figure 5
EWx1050G3	1050	1011	1264	1600	4 x 300 MCM	500 MCM	4 x 3 AWG	Figure 5
EWx1080G3	1080	1040	1300	1600	4 x 350 MCM	500 MCM	4 x 3 AWG	Figure 5
EWx1110G3	1110	1069	1337	1600	4 x 350 MCM	500 MCM	4 x 3 AWG	Figure 5
EWx1140G3	1140	1097	1372	1600	4 x 350 MCM	500 MCM	4 x 3 AWG	Figure 5
EWx1170G3	1170	1126	1408	1600	4 x 500 MCM	500 MCM	4 x 2 AWG	Figure 5
EWx1200G3	1200	1155	1444	1600	4 x 500 MCM	500 MCM	4 x 2 AWG	Figure 5

POWER SUPPLY WIRING EWx 600V 3-Phase 100KA SCCR - Copper 90°C

Model No	KW	Full Load Amps	MCA	Max OCPD	No of Wires x Min Wire Size/Phase	Max Wire Size/Phase	# of Ground Wires x Wire Size	Wiring Diagram
EWx30G3-100kA	30	29	37	40	1 x 10 AWG	2/0 AWG	1 x 10 AWG	Figure 1
EWx45G3-100kA	45	44	55	60	1 x 8 AWG	2/0 AWG	1 x 10 AWG	Figure 1
EWx60G3-100kA	60	58	73	80	1 x 6 AWG	2/0 AWG	1 x 8 AWG	Figure 1
EWx75G3-100kA	75	73	92	100	1 x 4 AWG	2/0 AWG	1 x 8 AWG	Figure 2
EWx90G3-100kA	90	87	109	110	1 x 3 AWG	2/0 AWG	1 x 6 AWG	Figure 2
EWx105G3-100kA	105	102	128	150	1 x 2 AWG	2/0 AWG	1 x 6 AWG	Figure 2

Model No	KW	Full Load Amps	MCA	Max OCPD	No of Wires x Min Wire Size/Phase	Max Wire Size/Phase	# of Ground Wires x Wire Size	Wiring Diagram
EWx120G3-100kA	120	116	145	150	1 x 1 AWG	2/0 AWG	1 x 6 AWG	Figure 2
EWx150G3-100kA	150	145	182	200	1 x 2/0 AWG	350 MCM	1 x 4 AWG	Figure 2
EWx180G3-100kA	180	174	218	225	1 x 3/0 AWG	350 MCM	1 x 4 AWG	Figure 2
EWx210G3-100kA	210	203	254	300	1 x 4/0 AWG	350 MCM	1 x 4 AWG	Figure 2
EWx240G3-100kA	240	231	289	300	1 x 250 MCM	350 MCM	1 x 4 AWG	Figure 2
EWx270G3-100kA	270	260	325	350	1 x 350 MCM	1000 MCM	1 x 3 AWG	Figure 2
EWx300G3-100kA	300	289	362	400	1 x 500 MCM	1000 MCM	1 x 2 AWG	Figure 2
EWx330G3-100kA	330	318	398	400	1 x 500 MCM	1000 MCM	1 x 2 AWG	Figure 2
EWx360G3-100kA	360	347	434	450	2 x 3/0 AWG	350 MCM	2 x 4 AWG	Figure 3
EWx390G3-100kA	390	376	470	500	2 x 4/0 AWG	350 MCM	2 x 4 AWG	Figure 3
EWx420G3-100kA	420	405	507	600	2 x 4/0 AWG	350 MCM	2 x 4 AWG	Figure 3
EWx450G3-100kA	450	434	543	600	2 x 250 MCM	350 MCM	2 x 4 AWG	Figure 3
EWx480G3-100kA	480	462	578	600	2 x 250 MCM	350 MCM	2 x 4 AWG	Figure 3
EWx510G3-100kA	510	491	614	700	2 x 300 MCM	350 MCM	2 x 3 AWG	Figure 3
EWx540G3-100kA	540	520	650	700	2 x 350 MCM	500 MCM	2 x 3 AWG	Figure 3
EWx570G3-100kA	570	549	687	700	2 x 350 MCM	500 MCM	2 x 3 AWG	Figure 3
EWx600G3-100kA	600	578	723	800	2 x 500 MCM	500 MCM	2 x 2 AWG	Figure 3
EWx630G3-100kA	630	607	759	800	2 x 500 MCM	500 MCM	2 x 2 AWG	Figure 3
EWx660G3-100kA	660	636	795	800	2 x 500 MCM	1000 MCM	2 x 2 AWG	Figure 4
EWx690G3-100kA	690	664	830	1000	2 x 500 MCM	1000 MCM	2 x 2 AWG	Figure 4

Model No	KW	Full Load Amps	MCA	Max OCPD	No of Wires x Min Wire Size/Phase	Max Wire Size/Phase	# of Ground Wires x Wire Size	Wiring Diagram
EWx720G3-100kA	720	693	867	1000	4 x 3/0 AWG	350 MCM	4 x 4 AWG	Figure 5
EWx750G3-100kA	750	722	903	1000	4 x 4/0 AWG	350 MCM	4 x 4 AWG	Figure 5
EWx780G3-100kA	780	751	939	1000	4 x 4/0 AWG	350 MCM	4 x 4 AWG	Figure 5
EWx810G3-100kA	810	780	975	1000	4 x 4/0 AWG	350 MCM	4 x 4 AWG	Figure 5
EWx840G3-100kA	840	809	1012	1200	4 x 4/0 AWG	350 MCM	4 x 4 AWG	Figure 5
EWx870G3-100kA	870	838	1048	1200	4 x 250 MCM	350 MCM	4 x 4 AWG	Figure 5
EWx900G3-100kA	900	867	1084	1200	4 x 250 MCM	350 MCM	4 x 4 AWG	Figure 5
EWx930G3-100kA	930	895	1119	1200	4 x 250 MCM	350 MCM	4 x 4 AWG	Figure 5
EWx960G3-100kA	960	924	1155	1200	4 x 250 MCM	350 MCM	4 x 4 AWG	Figure 5
EWx990G3-100kA	990	953	1192	1200	4 x 300 MCM	350 MCM	4 x 4 AWG	Figure 5
EWx1020G3-100kA	1020	982	1228	1600	4 x 300 MCM	350 MCM	4 x 3 AWG	Figure 5
EWx1050G3-100kA	1050	1011	1264	1600	4 x 300 MCM	500 MCM	4 x 3 AWG	Figure 5
EWx1080G3-100kA	1080	1040	1300	1600	4 x 350 MCM	500 MCM	4 x 3 AWG	Figure 5
EWx1110G3-100kA	1110	1069	1337	1600	4 x 350 MCM	500 MCM	4 x 3 AWG	Figure 5
EWx1140G3-100kA	1140	1097	1372	1600	4 x 350 MCM	500 MCM	4 x 3 AWG	Figure 5
EWx1170G3-100kA	1170	1126	1408	1600	4 x 500 MCM	500 MCM	4 x 2 AWG	Figure 5
EWx1200G3-100kA	1200	1155	1444	1600	4 x 500 MCM	500 MCM	4 x 2 AWG	Figure 5

Boiler Terminal Block Figures

Use the preceding applicable Power Supply Wiring charts to select the correct boiler terminal block figure:

Figure 10- Boiler Terminal Block Figures

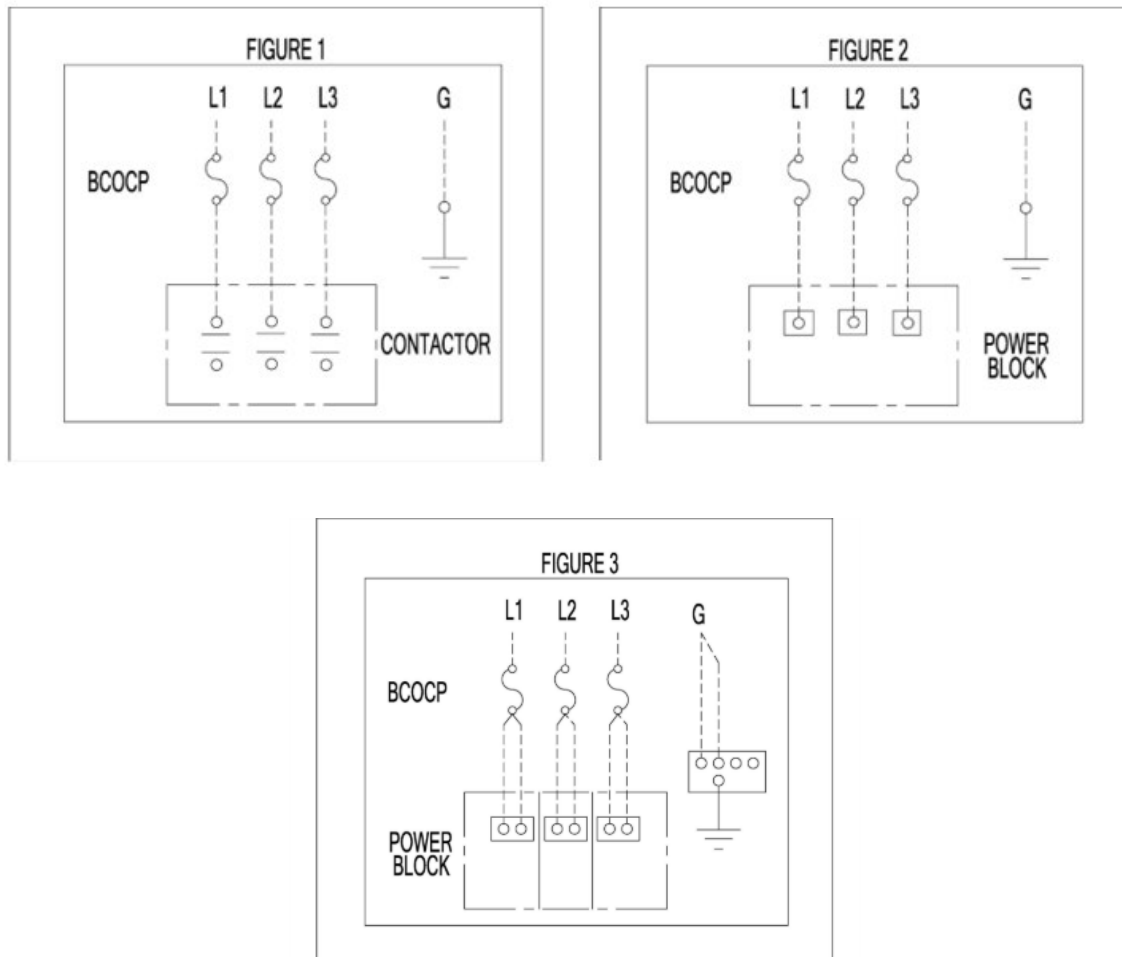

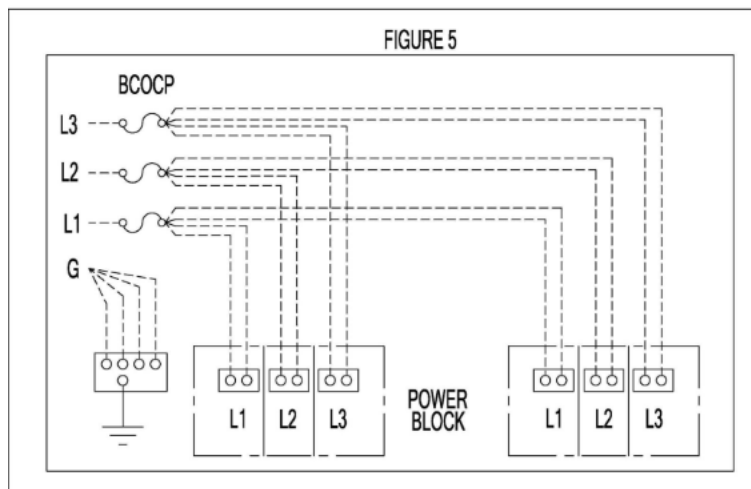
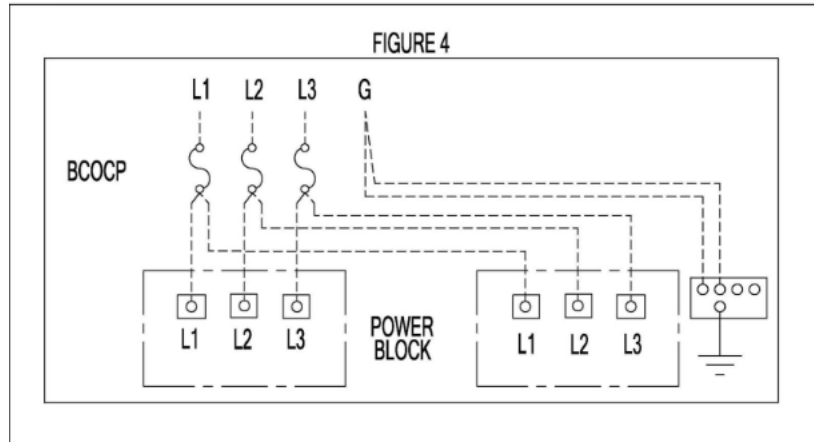

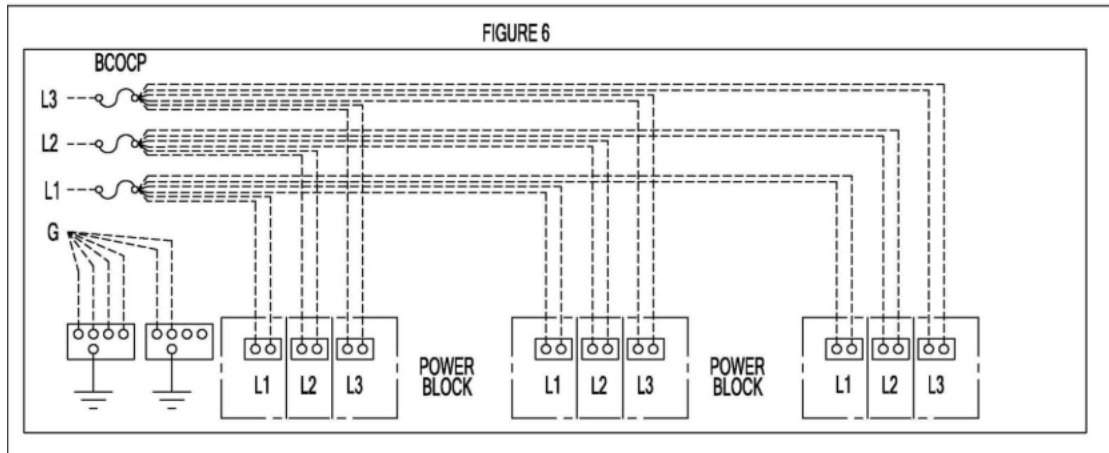

CONTROL CIRCUIT WIRING

Any alteration or addition to the control wiring may void the UL Listing and the Manufacturer's Limited Warranty.

The control circuit is 120VAC, single phase and a separate 120VAC; single phase service is required unless the boiler is factory outfitted with a control circuit transformer. The separate 120VAC service should be protected with a minimum 15-amp circuit breaker or fuse.

All field-installed controls, wiring modifications, or connections must receive written factory approval prior to installation.

FIELD INPUT AND OUTPUT CONTROL WIRING CONNECTIONS

Field control input and output wiring would be made at the enclosure box located above the boiler supply (outlet) water connection. Knockouts are provided on the box for conduit connections. Below and on the door of the box are the field control wiring terminals, including BACnet IP ethernet connections.

Figure 11- Field Input and Output Control Wiring Connections

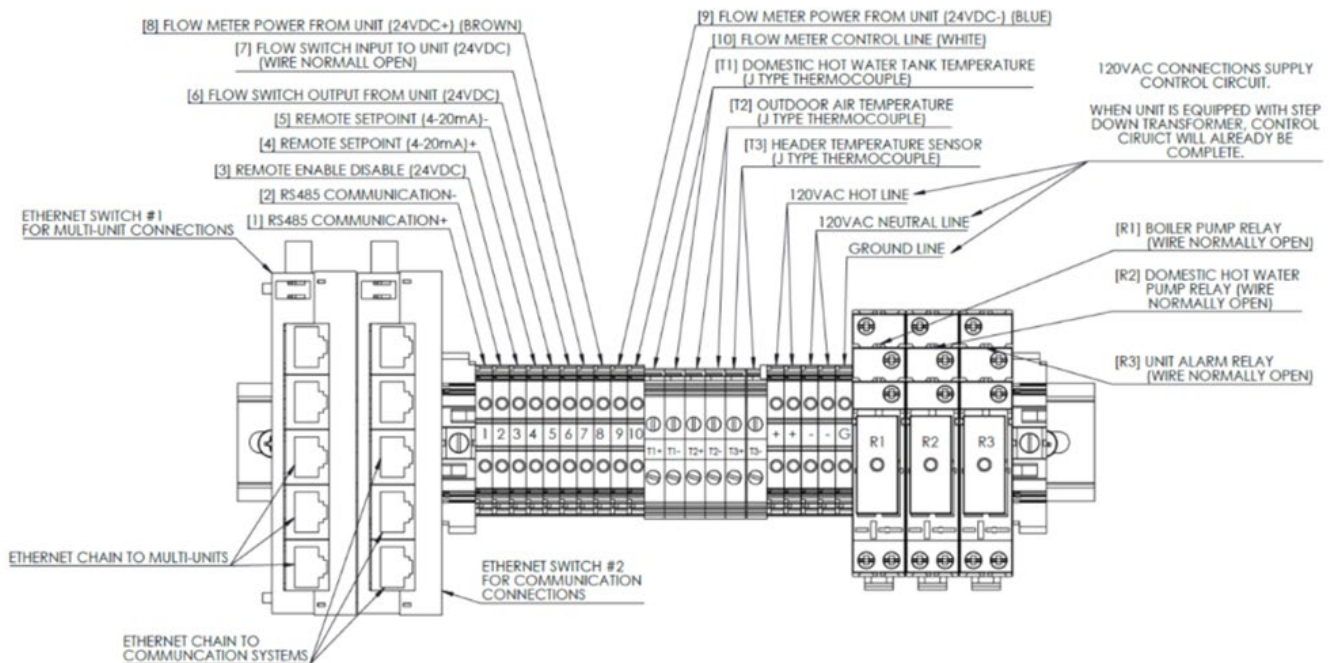

Section 4: Operation and Controls

General Description

Each EWx electric boiler consists of multiple cast ductile iron pressure vessels equipped with tubular resistance heating elements, inlet and outlet connections along a common header, a drain valve, water level control, pressure relief valve, and temperature control. These components are integrated with a coordinated electrical control system that enables fully automatic operation.

Startup and Water Level Control

When the boiler is energized, an electronic level sensor determines whether a low-water condition exists.

- **Low-Water Condition:** If detected, the heating elements remain de-energized until sufficient water enters the system.
- **Normal Condition:** If water level is adequate, the sensor allows the heating elements to energize, and the boiler begins heating immediately.

Recirculating Systems

In forced recirculation systems, water flow through the boiler is maintained by an external circulation pump (supplied by others).

Water enters through the lower inlet connection and exits through the upper outlet connection.

For design purposes, the pressure drop across the boiler can be approximated as equivalent to 10 feet of standard inlet piping.

Temperature Control and Safety Limits

Boiler operation is automatically regulated by a temperature control system.

- **Operating Temperature Control:** An adjustable temperature controller de-energizes the heating elements when the desired set point is reached.
- **High-Limit Protection:**
 - An automatic reset high-limit controller trips at 230°F, de-energizing the heating circuits and automatically resetting once temperature falls below 230°F.

- A manual reset high-limit controller provides redundant protection. If tripped, it must be manually reset before operation resumes.

Note: Cycling on either high-limit controller is not acceptable. The cause of any high-limit trip must be identified and corrected before resetting.

Pressure Relief Protection

Each boiler is equipped with a pressure relief valve that opens automatically when internal pressure approaches its set point. The relief valve is sized and set in accordance with ASME Section IV requirements and calibrated below the maximum allowable working pressure (MAWP) of the boiler and associated components.

Drainage and Maintenance

A drain valve is provided at the bottom of the inlet header to facilitate service. For ease of maintenance, the boiler should be installed with threaded or flanged connections and stop valves on both the inlet and outlet, allowing the boiler to be isolated and drained without emptying the entire system.

Inspection and Preventive Maintenance

Periodic internal inspection of the vessel water side is recommended to detect early signs of corrosion, scaling, or deposits. For inspection of frequency and requirements, consult the local boiler inspection authority or applicable code of jurisdiction. Inspection is performed by removing a heating element from each vessel section.

PREPARATION FOR OPERATION

Before operating the boiler, verify that installation, piping, and electrical connections have been completed in accordance with Sections 2 & 3 of this manual. Ensure that all piping has been thoroughly flushed and is free of debris.

STARTUP PROCEDURE

Pre-Startup Checks

System Preparation

1. Confirm that the boiler and connected piping are completely filled with water, and all air has been purged.
2. Open all valves to allow unrestricted flow to and from the boiler.

Pressurize the system and confirm it meets the minimum flow specifications in Section 2, *Figure 3 – EWx Series Minimum and Maximum Water Flow*

Leak Inspection

Inspect all piping connections for leaks.

- Correct external leaks before proceeding.
- If a leak is suspected within the EWx pressure vessel assembly, contact your authorized DHT/Sussman Electric Boilers (SEB) representative for assistance.

Electrical Verification

1. Tighten all electrical connections to specified torque values.
2. Confirm correct line voltage at the main disconnect.

System Quality and Optional Equipment

- Ensure the water supply meets DHT's specified water quality standards.
- Verify that all optional accessories or control equipment are installed and tested for proper operation.

Power Supply and Initialization

1. *Apply Main Power*
Turn on the main disconnect to energize the EWx power block.
 - a. If the unit includes a control voltage transformer, this will also power the 120VAC control circuit.

b. If not, supply 120VAC control power via a separate circuit.

2. *Energize Control Circuit*

- a. Press the Green Power button on the front of the EWx boiler to energize the control panel and HMI touchscreen.
- b. The display will illuminate and begin its start-up sequence, typically completing initialization within 60–90 seconds.

3. *Access Control Interface*

Refer to Section [Controls Overview] for detailed navigation and function descriptions.

Start-Up Preparation

Before enabling operation, confirm the following:

Component	Required Position
Water Outlet	Open
Water Inlet	Open
Drain Valve	Closed
Feed Water Valve	Open
Circulation Pump	Off
Main Power	Off

Then:

- Fill the system completely and vent any trapped air.
- Ensure control panel and heating element covers are securely closed.
- Verify that all personnel are aware that start-up is commencing.
- Start the circulation pump (if applicable) and confirm balanced flow through all units.
- Inspect for leaks and vent air again if required.

Note: In areas with hard water, water treatment is strongly recommended to prevent scale formation and extend element life.

Control System Start-Up

1. *Turn On Main Power*

Place the main disconnect switch in the ON position. If control power is supplied separately, energize that circuit.

2. *Activate the Control System*

Press the Green Control Power button below the HMI touchscreen. Both the button and the display should be illuminated.

3. *Run the Setup Wizard*

On the welcome screen, select SETUP WIZARD to configure the boiler for operation.

- a. Navigate with NEXT and BACK buttons.
- b. Verify factory default parameters or modify as required.
- c. Set the temperature set point lower than the high-limit thresholds.

Operation Modes

Constant Set-Point Mode

This is the standard operating mode.

- Set the desired temperature via the HMI or external signal.
- The set point may also be controlled through 4–20 mA input, dry contacts, or a Building Automation System (BAS).

Note: BAS and analog control inputs override local HMI settings.

Outdoor Reset Schedule Mode

If equipped with an outdoor temperature sensor, the EWx can operate in Outdoor Reset mode.

- Verify proper sensor installation per Section [Outdoor Reset Installation].
- Select Outdoor Reset Schedule Set Point in the Setup Wizard.
- Configure high/low set points and corresponding outdoor temperature ranges.
- Factory defaults may be used as a baseline.

- If the outdoor sensor fails or reads outside of expected range, the system automatically reverts to Constant Set-Point Mode.

Enabling Boiler Operation

1. From the dashboard menu, navigate to TESTING / TROUBLESHOOTING.
2. Toggle the ENABLE/DISABLE switch to ENABLE (indicator turns red).
3. Navigate to SETTINGS and press ON. The button will illuminate green.
4. Verify that no alarms are present. Resolve any issues before proceeding.

Common Faults and Resolutions:

- *Low Water Cut-Off (LWCO):* Press the external LWCO reset. Ensure the boiler is fully filled before resetting it again.
- *Operating Temperature Limit:* Indicates temperature exceeded 230°F. Power down, inspect wiring and controls, correct the fault, and restart.
- *High Temperature Limit:* Indicates manual reset trip. Verify temperature and wiring before resetting.

Final Verification

- Observe the pressure/temperature gauge at the boiler outlet—temperature should rise steadily toward the set point.
- Monitor inlet/outlet temperatures and key parameters via the HMI STATUS page.
- When set point is reached, the controller automatically de-energizes the heaters.
- Perform a final inspection for leaks and verify stable operation.
- With continuous full load on the boiler, confirm that all heating circuits are on (all contactors on) and measure the full boiler amperage draw. It should be within 4% of the rated amperage on the boiler nameplate.
- Complete the Boiler Startup Check List and return to SEB@dhtnet.com

Note: Pre-boiling is not required. All internal surfaces and heating elements are pre-cleaned prior to shipment.

Section 5- EWx Control Functions

Controls Introduction

This section explains how to operate the EWx Electric Hot Water Boiler from the front-panel touchscreen, how to use the Setup Wizard, and how to complete the controls start-up for constant set point, outdoor reset, space heating, domestic hot water (DHW), and multiple-boiler applications. It also covers the key diagnostic and communication screens used during commissioning and service.

NOTE: The touchscreen uses projected capacitive technology, allowing users to zoom in and out on small text and figures using a two-finger pinch gesture. This functionality is available on all display screens.

Safety Information – Controls & Start-Up



WARNING

ELECTRIC SHOCK AND BURN HAZARD

Improper wiring, grounding, or servicing can result in serious injury or death. Only qualified personnel familiar with applicable codes and this equipment should install or service the EWx boiler.



WARNING

HOT SURFACES AND PRESSURIZED SYSTEM

The boiler, piping, and system water can be hot and under pressure. Always follow lockout/tagout procedures, relieve system pressure as required, and allow components to cool before servicing.



CAUTION

EQUIPMENT DAMAGE

Incorrect configuration of set points, applications, or communication parameters can cause nuisance trips, poor performance, or equipment damage. Follow the procedures in this manual and any additional instructions from Diversified Heat Transfer (DHT)/Sussman Electric Boiler (SEB).

NOTE: The EWx controller and HMI are factory-configured for the specified job, but final verification and adjustment must be completed during start-up.

Overview of On-Screen Navigation

After main power and control power are applied and the green front-panel POWER button is pressed, the touchscreen boots up. The **Welcome screen** appears approximately 60–90 seconds after power-up.

Figure 11 – Welcome Screen

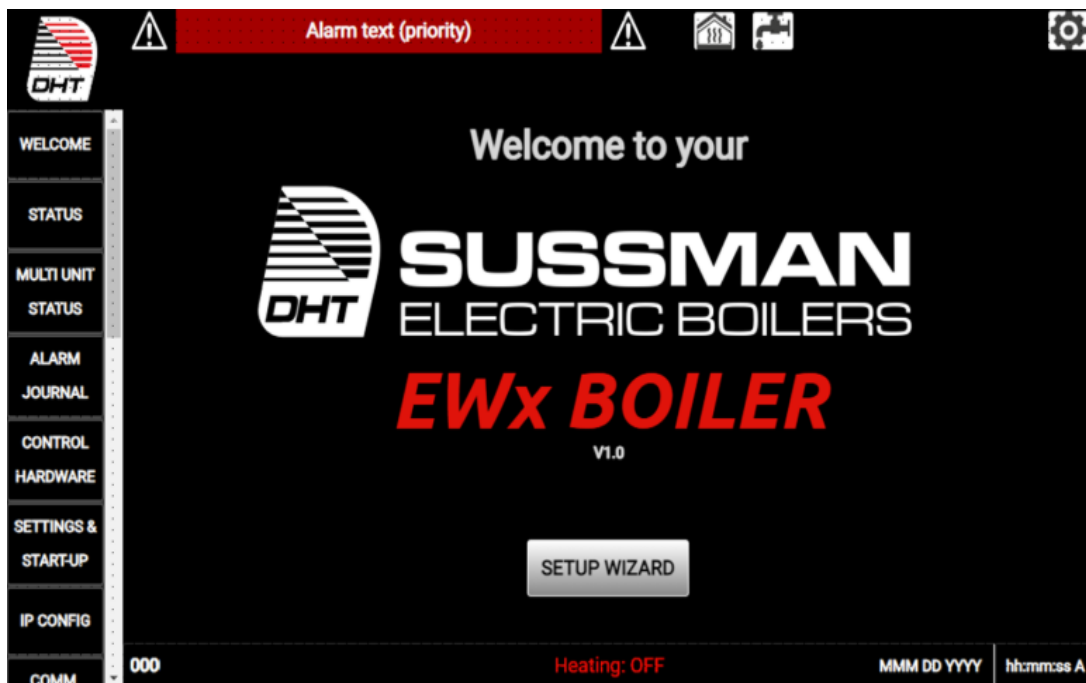

Status Ribbon (Top of Screen)

Provides global navigation and system alerts.

Includes:

Alarm Notification Box

- Appears only when there is an active alarm preventing proper operation.
- Displays a brief alarm title.
- Action: Press the red alarm box to open the Alarm Journal display.

Functional Mode Icons

- Space Heating indicator (house with heat waves): unit configured for space heating operation.



- Domestic Hot Water (DHW) indicator (faucet): unit configured for DHW operation.



- Both icons appear when the unit is configured for space heat + DHW.

Settings Button (Gear icon)

- Located at the right end of the Status Ribbon.
- Press to open the **Settings & Start-Up** display

Function Ribbon (Bottom of Screen)

Shows operational indicators and access tools.

Right side:

- Shows current **Date and Time**.
- Press the date or time field to correct if necessary (on-screen prompt will guide entry).

Center:

- **Function Status Indicator**
 - Displays current operating mode:
 - “Heating: OFF” (red text) when not heating.

- “Heating: SPACE HEAT” (green text) during space heating.
- “Heating: DHW” (green text) during DHW operation.

Left side:

- **Boiler Number Indicator**
 - Shows the boiler’s ID within a multiple boiler system.
 - Standalone units will display “1”.
 - In multi-unit systems, boilers are numbered sequentially from 1 to the total number configured.

Display Navigator (Left Vertical Scroll Bar)

- Vertical list of available displays (STATUS, SETTINGS, ALARM JOURNAL, etc.).
- The list changes depending on the **Security Level**:
- Higher levels (e.g., Level 1, Level 2) reveal additional setup and diagnostic screens.

Setup Wizard Button

- Located on the Welcome screen under the **Sussman Electric Boilers** and **EWx** logos.
- Opens the **Setup Wizard**, which walks through configurable options.
- Access requires **Security Level 1** login.

NOTE: Units ship pre-configured from factory. Only change settings when required by site conditions

Figure 12 – Setup Wizard

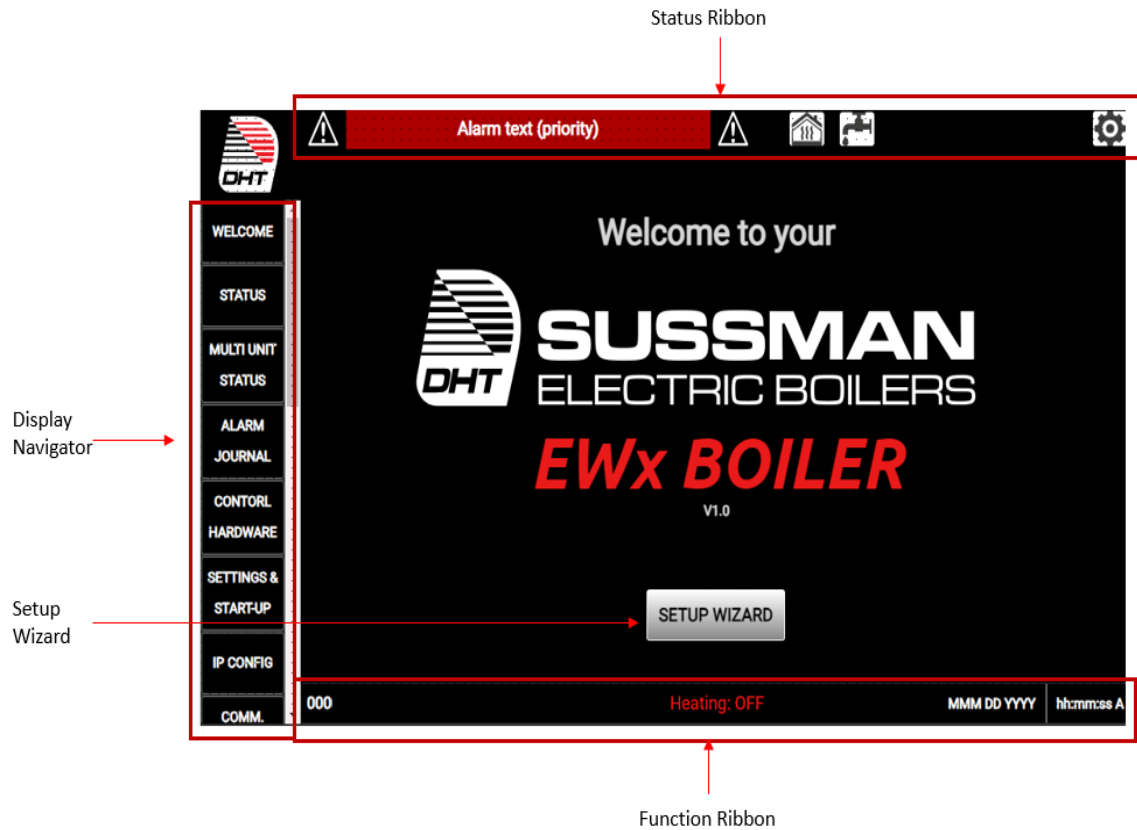

Key Display Descriptions

The EWx controller provides multiple display pages, including: Welcome, Setup Displays 1–10, various Status Displays, Alarm Journal, Graphical Trend Data, Control Hardware, Settings, Boiler Data, Security Login, Testing/Troubleshooting, Contactor Control, PID Control, IP Configuration, and Communication Parameters.

Status Display (Default)

The **STATUS** display provides real-time operating information:

Live Data

- **Current Set Point**- Displays the active temperature set point or “IDLE” if no heating mode is active.
- **Current Heating Mode**- “SPACE HEATING”, “DHW”, or “IDLE”.
- **Electrical Panel Temperature**- Temperature inside the electrical cabinet.
- **Flow Indicator** (if equipped)- Shows flow information when a flow meter is installed and enabled via Setup Wizard.
- **Current kW Output**
- **Unit Percentage Output**
 - **SCR Percentage Output**- All three values are live and change as the unit modulates.
 - **Header Sensor Temperature** (if equipped) - Shows temperature when a header sensor is installed and enabled via Setup Wizard

Temperature Gauges

- **Outlet Temperature** gauge.
- **Inlet Temperature** gauge.
- Colored arcs show temperature level.
- **Element Map (Lower Left)**
 - Graphical representation of heating elements and contactors. (Changes based on total number of elements in boiler)
 - Boxes light green when elements are energized.
 - “Total Elements On” count shows active elements.
- **Switch Display Button (top of the Status page)**
 - Cycles between:
 - Base **STATUS** layout.
 - **DHW status visualization** (tank, pump, piping) when DHW is configured.
 - **Outdoor Reset** schedule graph when Outdoor Reset is configured.
 - Not present if the unit is set up only for Constant Set Point mode.

STATUS Base Display

Figure 13 – Status Base Display

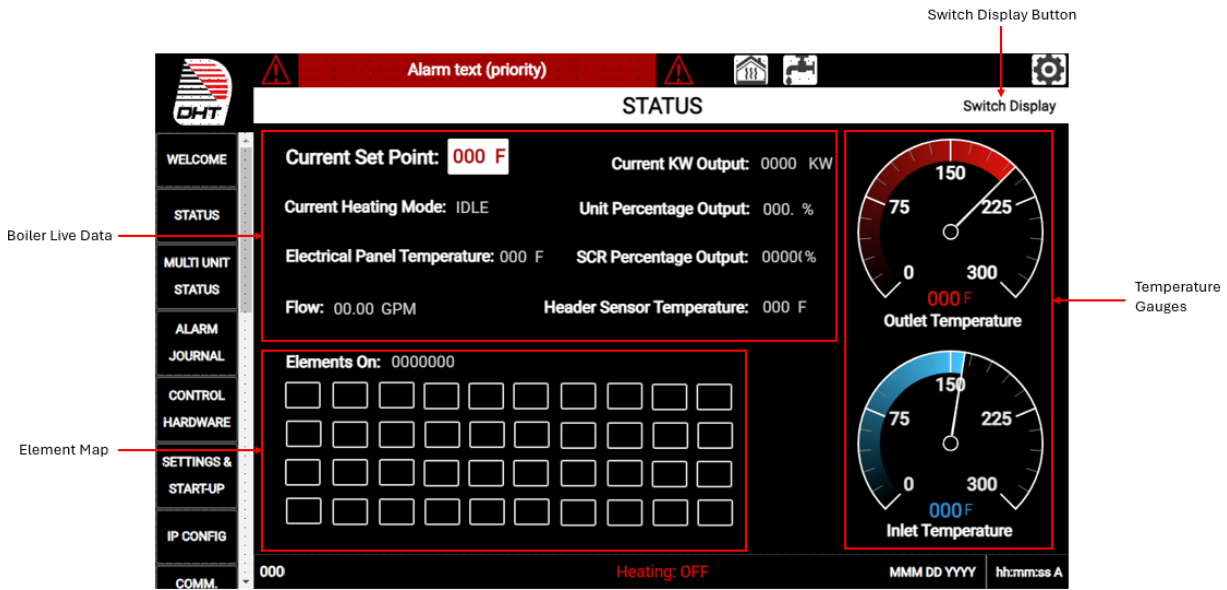

STATUS Display Domestic Hot Water

- Displays boiler live data
- Boiler outlet temperature
- Tank set point and dead band
- Current tank temperature
 - Tank will be red in color when temperature is between dead band and set point
- Pump Status
 - Pump will be green in color when running and gray when turned off.

Figure 13 – Status Display- Domestic Hot Water

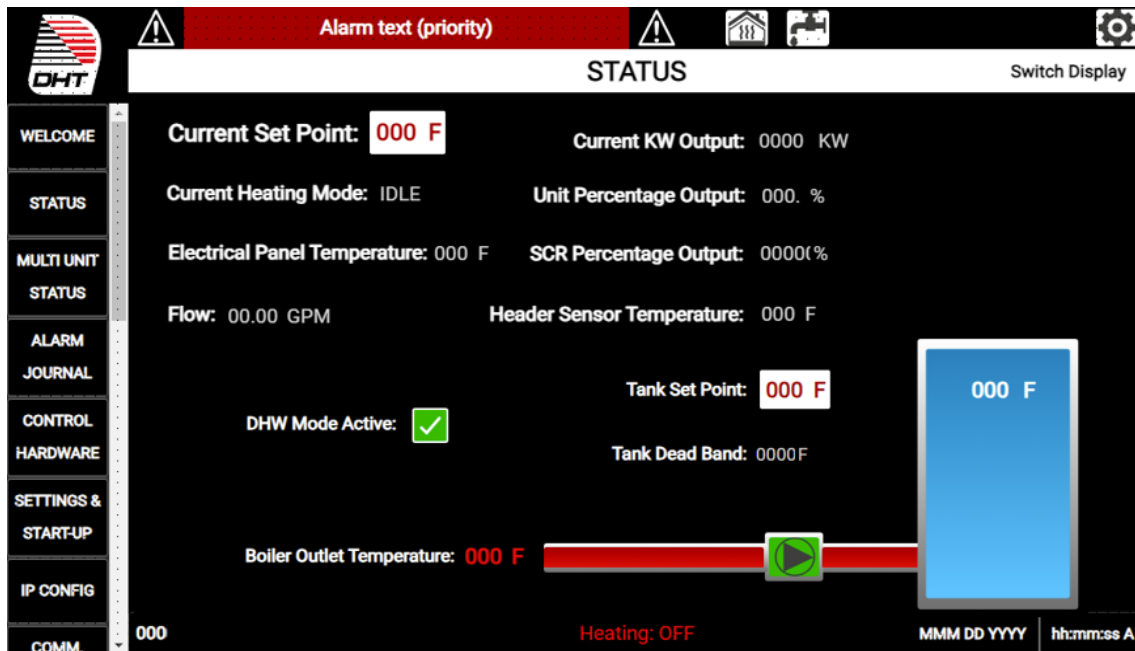

STATUS Display Outdoor Reset

- Displays boiler live data
- Outside air temperature vs boiler setpoint graph

Figure 14 – Status Display- Outdoor Reset

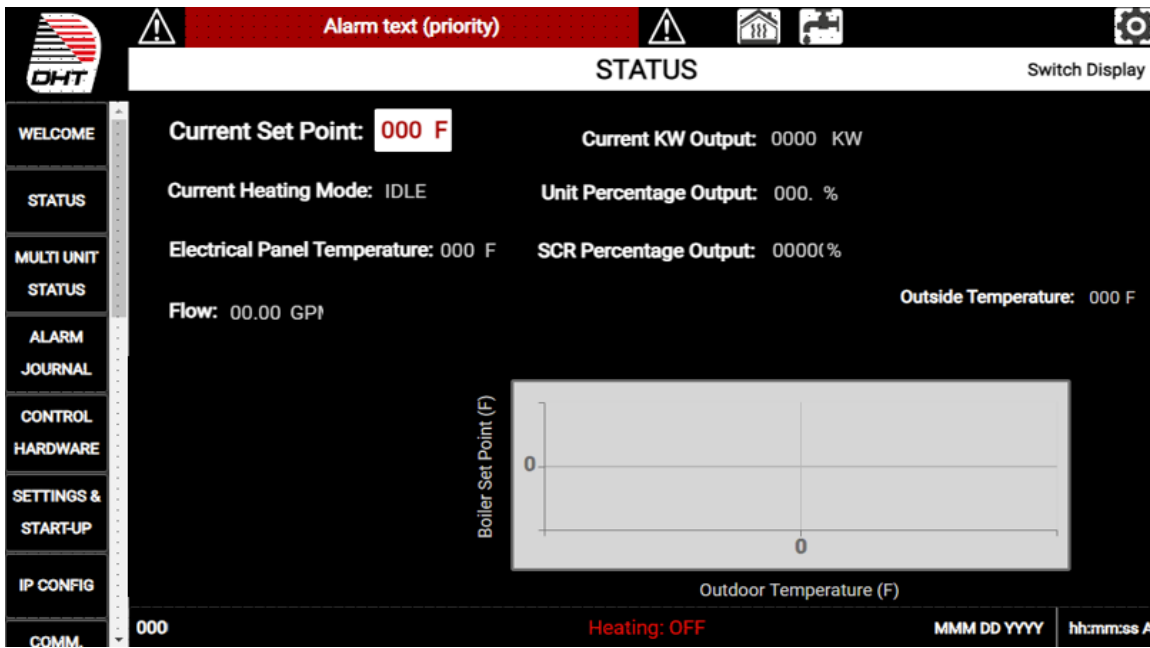

Multi-Unit Status Display

- Visible only on the Primary Boiler when multiple boiler applications are enabled:
 - Shows:
 - Primary boiler heating mode (DHW, SPACE HEAT, or IDLE).
 - Current Set Point for the active mode.
 - Each boiler's:
 - Connection status.
 - Outlet temperature.
 - Number of boiler icons matches the configured number of boilers in the system.

Figure 15– Multi-Unit Status Display

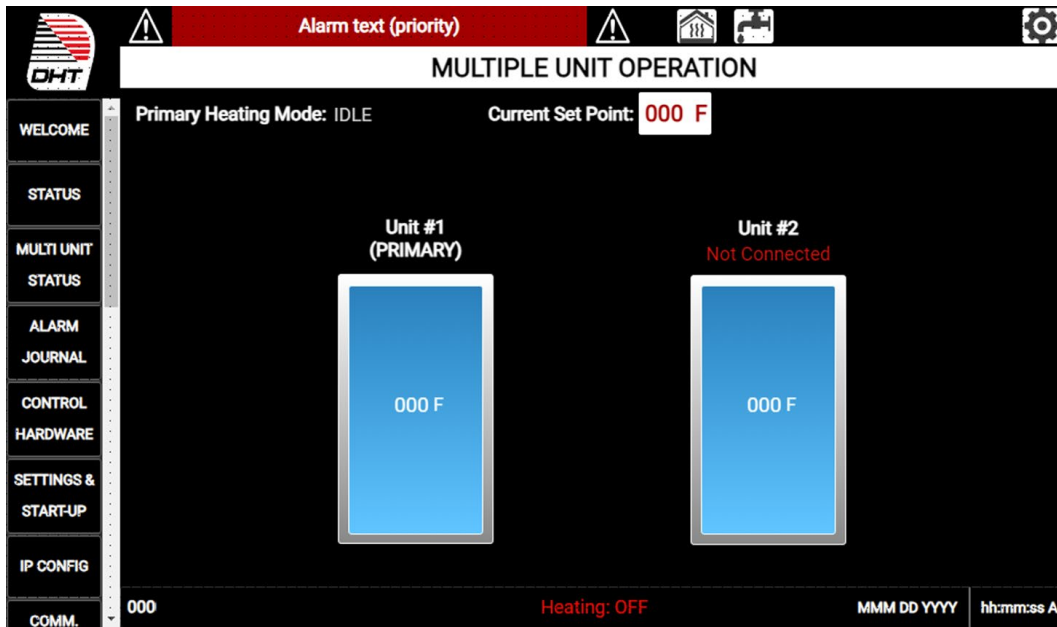

Alarm Journal

- Tracks current and historical alarms since last power-up:
- Displays:
 - Alarm number (internal use).
 - Active and inactive time stamps.
 - Description text.
- Active alarms:
 - Highlighted in red with white text.
- Inactive alarms:
 - Highlighted in white with black text.
- Most recent active alarm is also shown in the **Alarm Notification** box on the Status Ribbon; pressing that box opens the Alarm Journal.

Figure 16– Alarm Journal

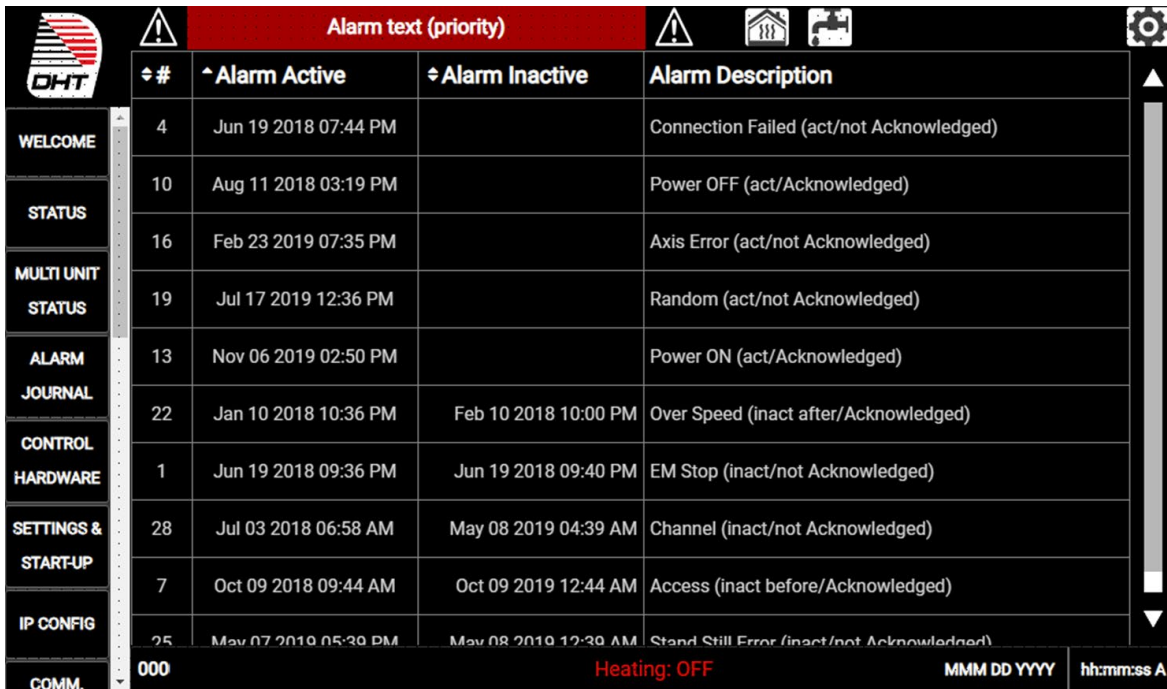

		Alarm text (priority)			
#	Alarm Active	Alarm Inactive	Alarm Description		
4	Jun 19 2018 07:44 PM		Connection Failed (act/not Acknowledged)		
10	Aug 11 2018 03:19 PM		Power OFF (act/Acknowledged)		
16	Feb 23 2019 07:35 PM		Axis Error (act/not Acknowledged)		
19	Jul 17 2019 12:36 PM		Random (act/not Acknowledged)		
13	Nov 06 2019 02:50 PM		Power ON (act/Acknowledged)		
22	Jan 10 2018 10:36 PM	Feb 10 2018 10:00 PM	Over Speed (inact after/Acknowledged)		
1	Jun 19 2018 09:36 PM	Jun 19 2018 09:40 PM	EM Stop (inact/not Acknowledged)		
28	Jul 03 2018 06:58 AM	May 08 2019 04:39 AM	Channel (inact/not Acknowledged)		
7	Oct 09 2018 09:44 AM	Oct 09 2019 12:44 AM	Access (inact before/Acknowledged)		
25	May 07 2019 05:39 PM	May 08 2019 12:39 AM	Stand Still Error (inact/not Acknowledged)		
000			Heating: OFF		MMM DD YYYY hh:mm:ss A

Control Hardware Display

- Shows the internal control modules.
- Use with wiring diagrams to:
- Confirm correct wiring.
- Identify potential faulty modules.
- Useful during commissioning and troubleshooting.

Figure 17– Control Hardware Display

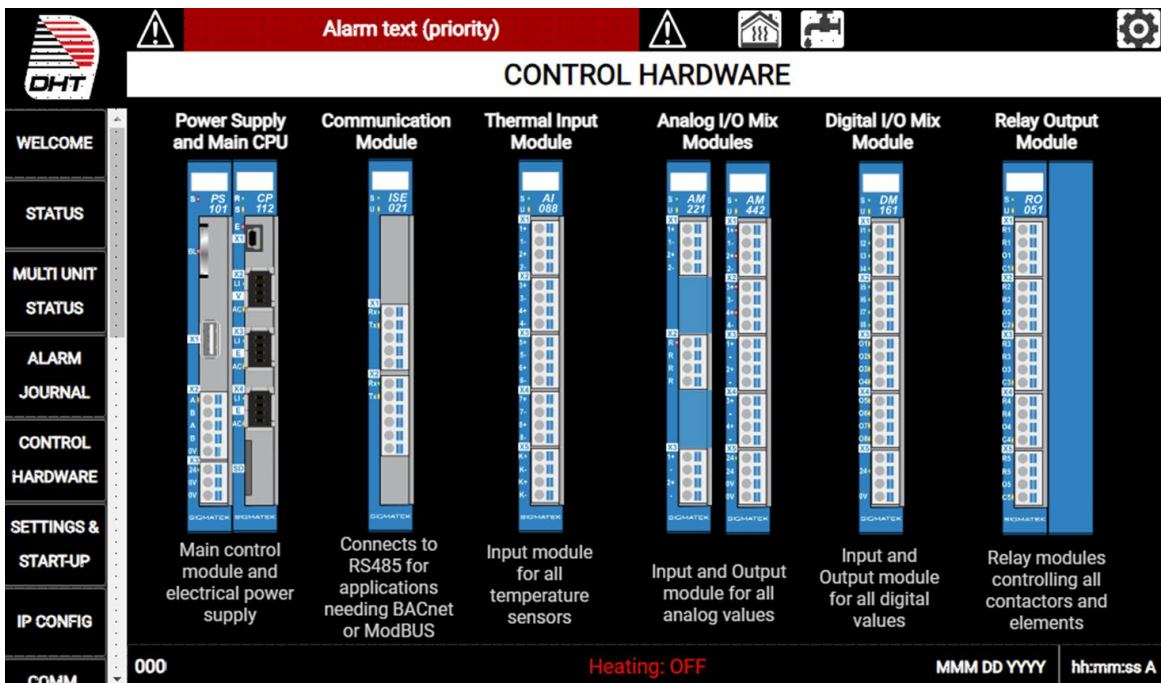

Security Login Display

Accessed from:

- Display Navigator, or
 - Change Security Level button on the Settings & Start-Up display.
 - Use provided usernames/passwords to log into different security levels (e.g., operator, Level 1, Level 2).
 - Higher levels allow access to Setup Wizard, communication settings, PID adjustments, and contactor control.

Figure 18– Security Login Display

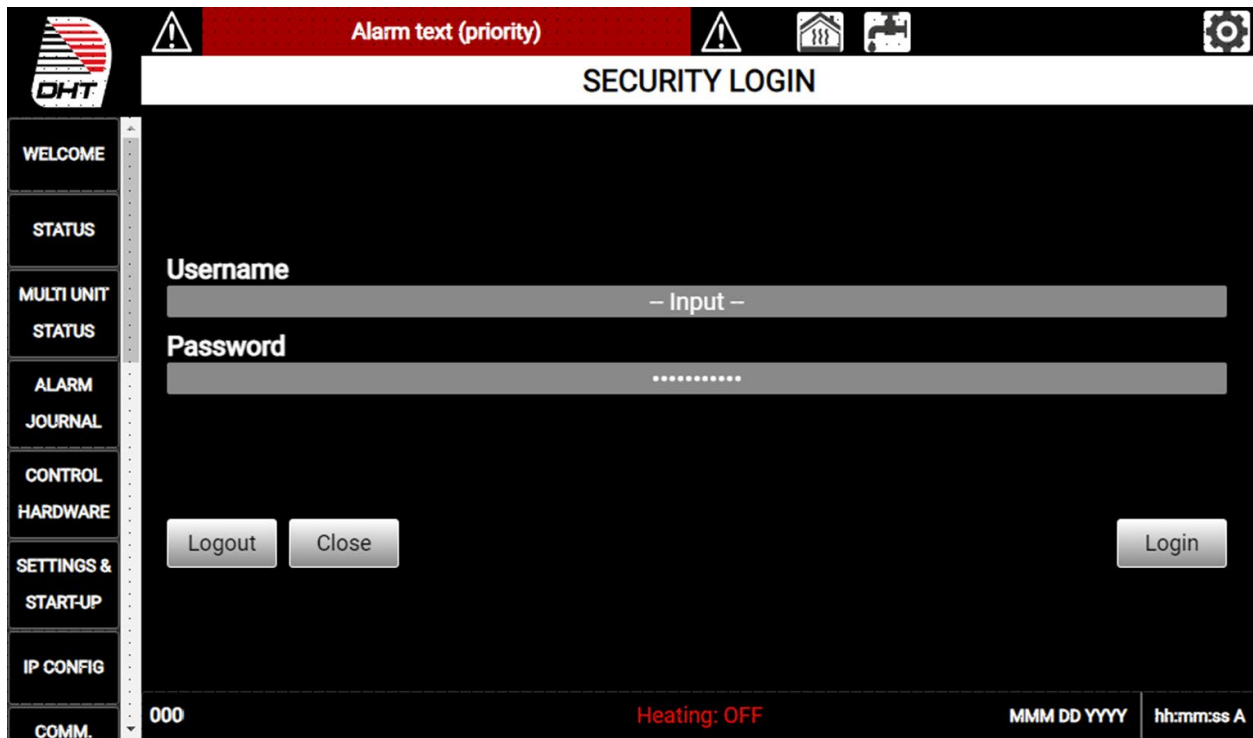

The screenshot shows the Security Login Display interface. At the top, there is a red bar for "Alarm text (priority)" with a warning icon. Below this is a black bar with the DHT logo, a warning icon, a home icon, a printer icon, and a settings icon. The main title is "SECURITY LOGIN". On the left, there is a vertical menu with items: WELCOME, STATUS, MULTI UNIT STATUS, ALARM JOURNAL, CONTROL HARDWARE, SETTINGS & START-UP, IP CONFIG, and COMM. The main area contains "Username" and "Password" input fields. Below the password field are "Logout", "Close", and "Login" buttons. At the bottom, there is a status bar with "000", "Heating: OFF", and a date/time display "MMM DD YYYY hh:mm:ss A".

Boiler Data Display

Displays key boiler information:

- Model number.
- Serial number.
- Maximum kW output.
- Unit voltage.
- Number of stages/elements.
- Required unit amperage.
- Functional set point type (constant or outdoor reset).

Figure 19– Boiler Data Display

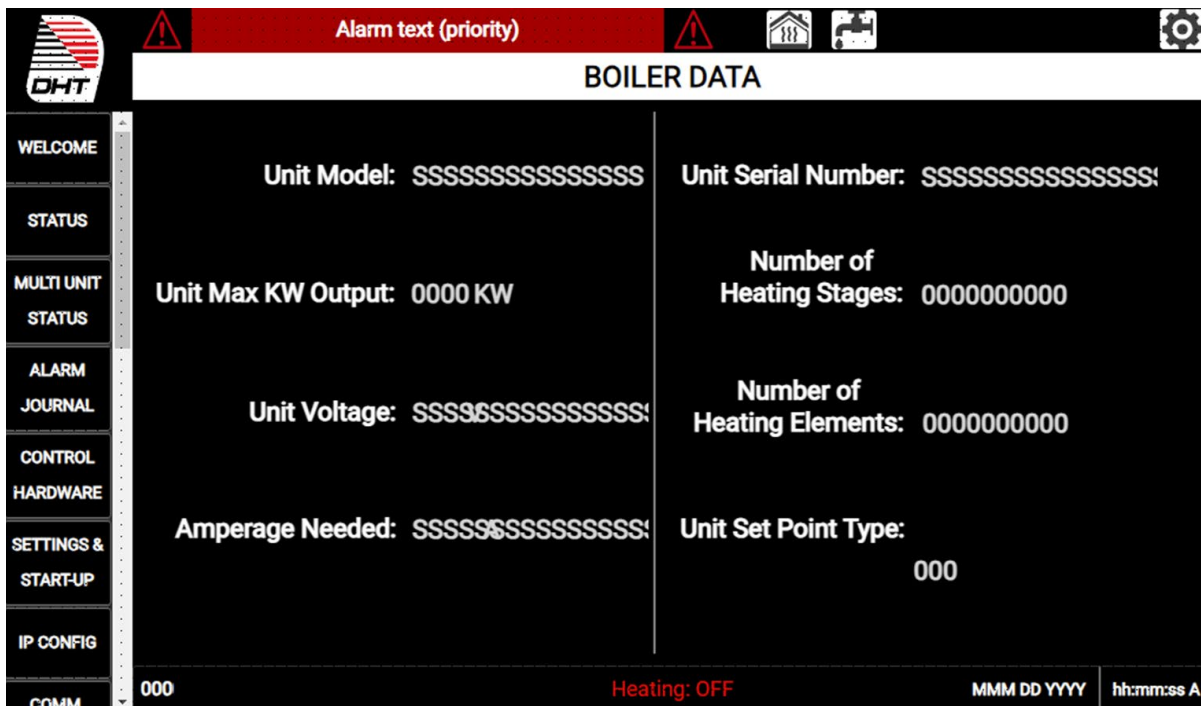

Testing/Troubleshooting Display

- Available at **Security Level 1**.
 - **LEVEL 1 Access**
 - Username: startset
 - Password: dheat439
- Used to monitor and test certain inputs/outputs.
- **Manual Mode Toggle**
 - When ON: unit will **not** run in normal operation; used for troubleshooting only.
- **Override Enable/Disable**
 - Can be toggled without Manual Mode; must be enabled to run the boiler.
- Additional toggles (when in Manual Mode) for:
 - Space heating call for heat
 - DHW call for heat
 - Electrical panel fan
 - Flow switch (if installed)
 - Space heat pump
 - DHW pump



WARNING

WHEN MANUAL MODE IS ENABLED, NORMAL SAFETY AND CONTROL SEQUENCES MAY BE BYPASSED. ONLY QUALIFIED SERVICE PERSONNEL SHOULD USE MANUAL MODE, AND ONLY FOR SHORT-TERM DIAGNOSTICS.

Figure 20– Testing/Troubleshooting Display

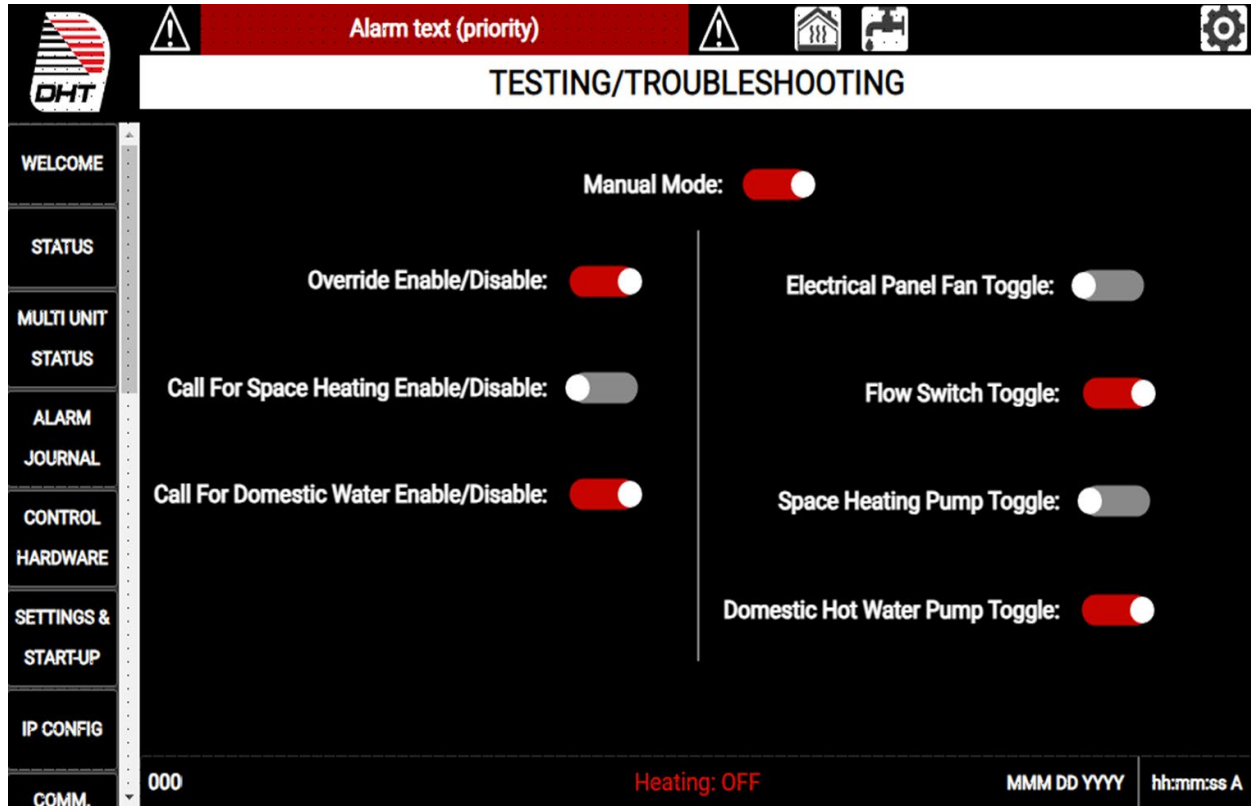

PID Control Display

- Available at **Security Level 2**. (Note: Contact factory for login information).
- Adjusts the PID parameters that govern how the boiler modulates to maintain set point.
- Includes an **Autotune PID** function to match boiler response to system dynamics.



CAUTION

Do not change PID values unless instructed by DHT/SEB or a qualified representative. Incorrect PID settings can cause instability, short cycling, or poor temperature control.

Figure 20– PID Control Display

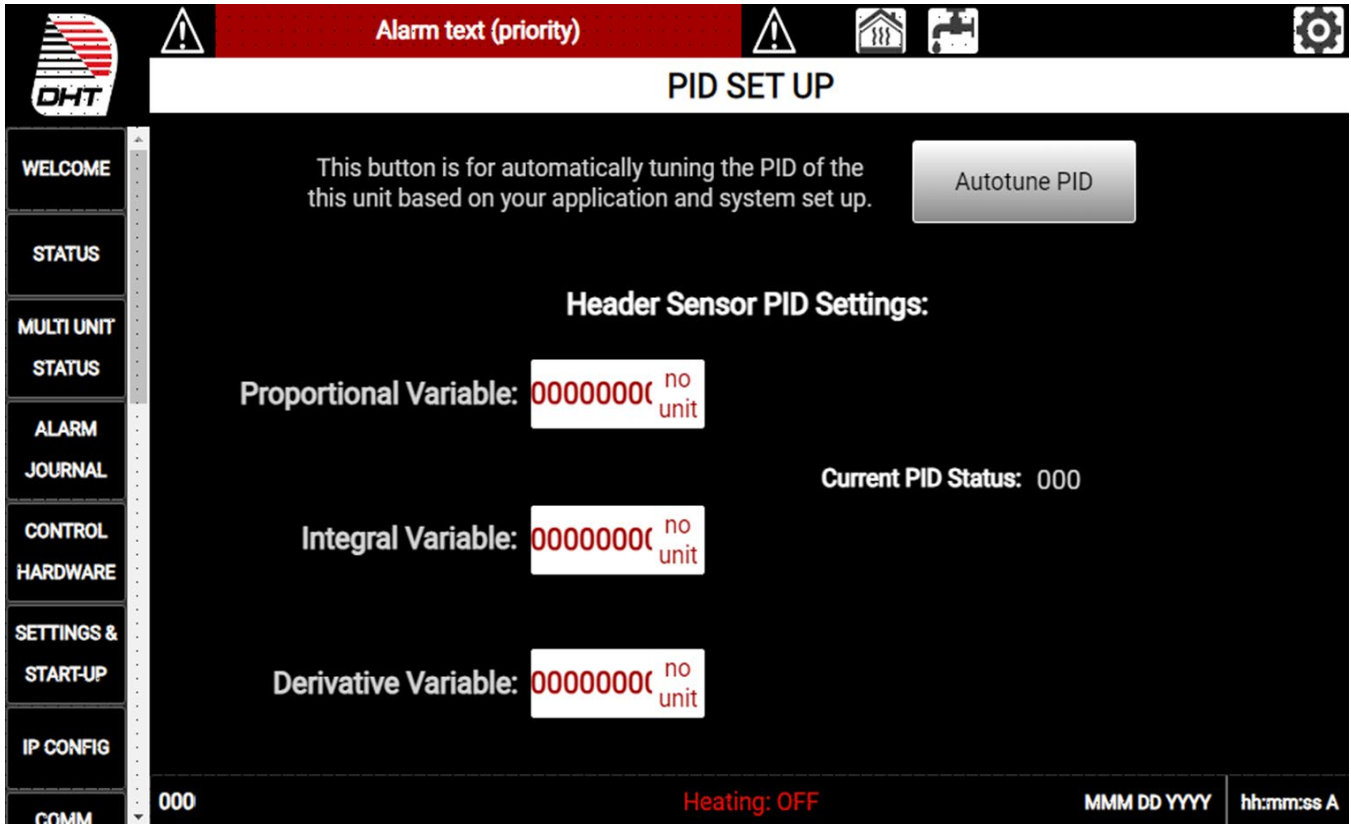

Contactor Control Display

- Accessible only with **Security Level 2** and **Manual Mode** turned ON.
- Allows individual contactors/elements to be switched ON or OFF for:
 - Amperage checks.
 - Continuity checks.
 - Contact closure verification.
- System behavior:
 - Contactors revert to normal state when Manual Mode is turned OFF.
 - Each contactor toggle has an automatic 30-second timeout to prevent overshoot or misuse.
 - A second Contactor Control page appears if the unit has more than 10 contactors.

Figure 21– Contactor Control Display

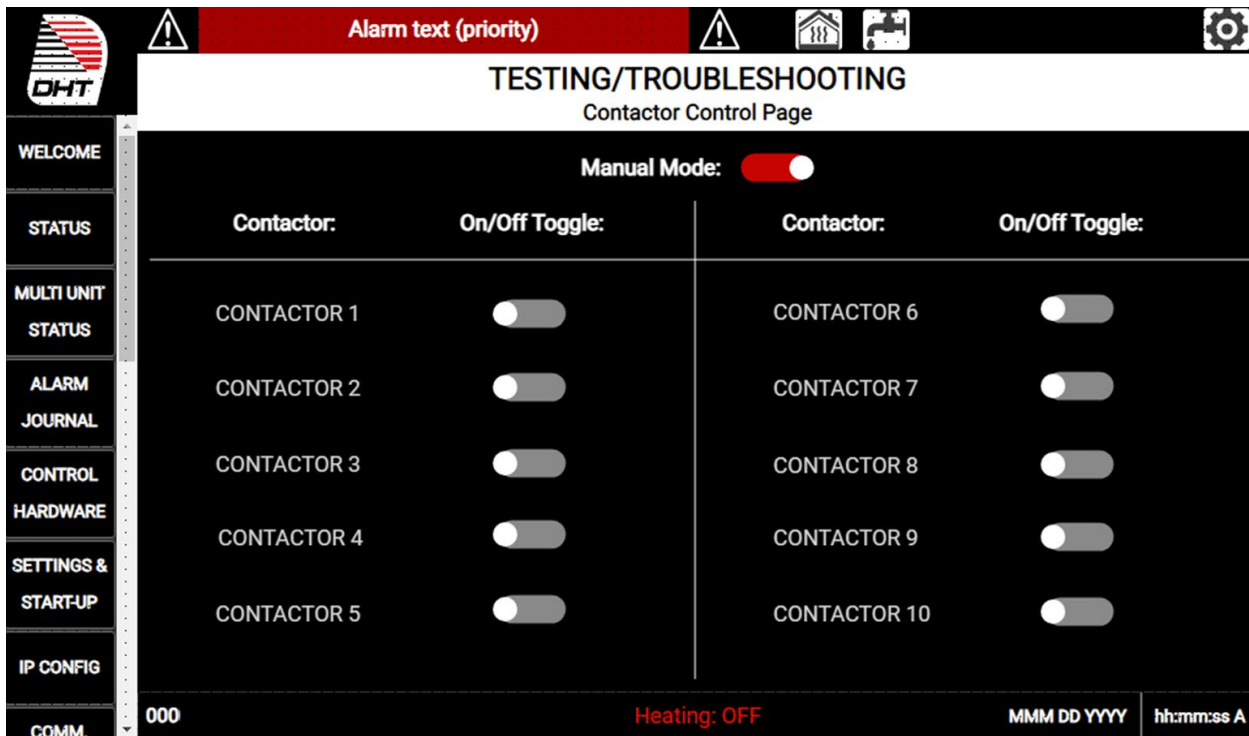

IP Configuration Display

- **IP Configuration (IP CONFIG)**
 - Available at **Security Level 2**.
 - Allows IP address changes for control module and HMI.
 - **Only HMI Port 2** needs to be modified for building automation communication.
 - Press **Set IP** after entering new values to save.

Figure 22– IP Configuration Display

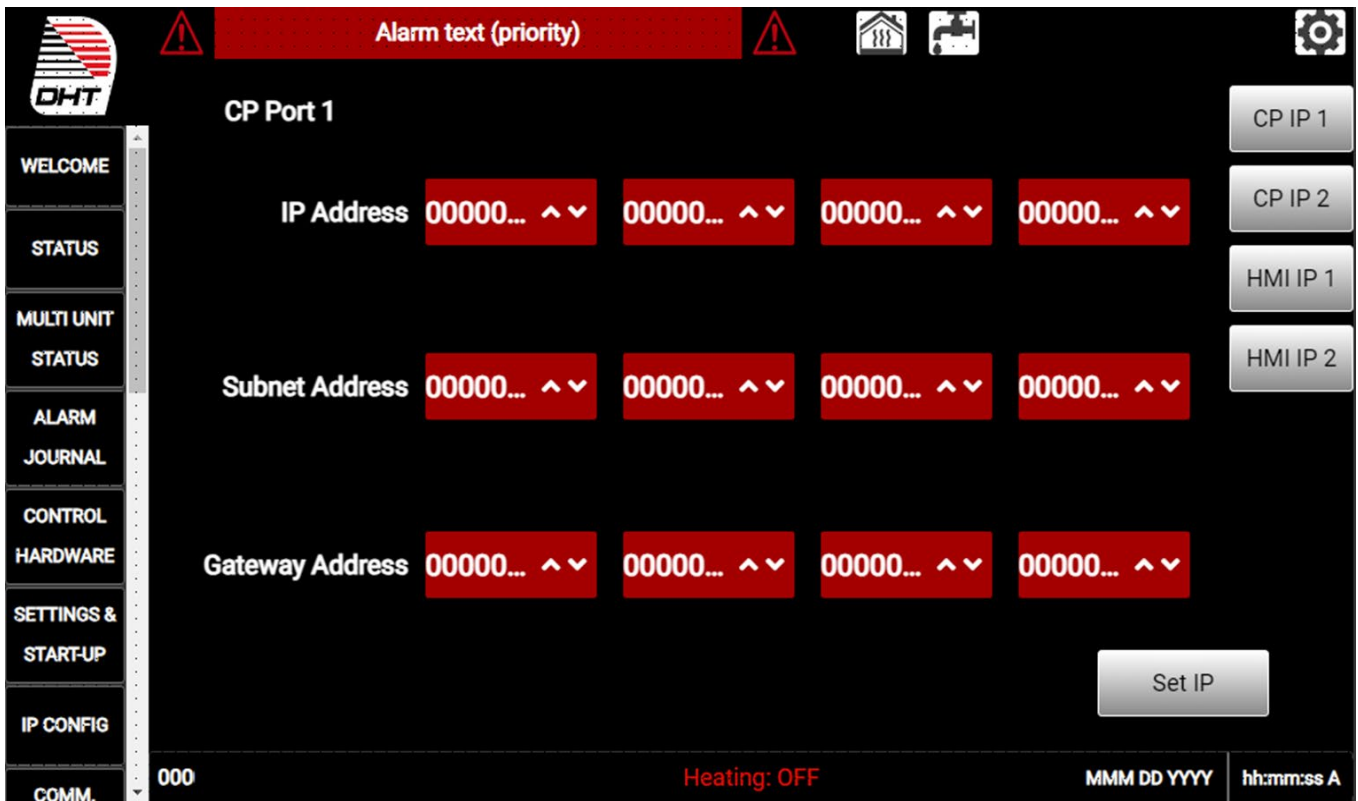

Communication Parameters Display

- **Communication Parameters (COMM. PARAMS.)**
 - Available at **Security Level 2**.
 - Allows configuration of:
 - BACnet Device ID.
 - Modbus TCP Port.
 - Modbus RTU Baud Rate.
 - Modbus RTU Address.
 - Press **Confirm Settings** to save changes.

Figure 22– Communication Parameters Display

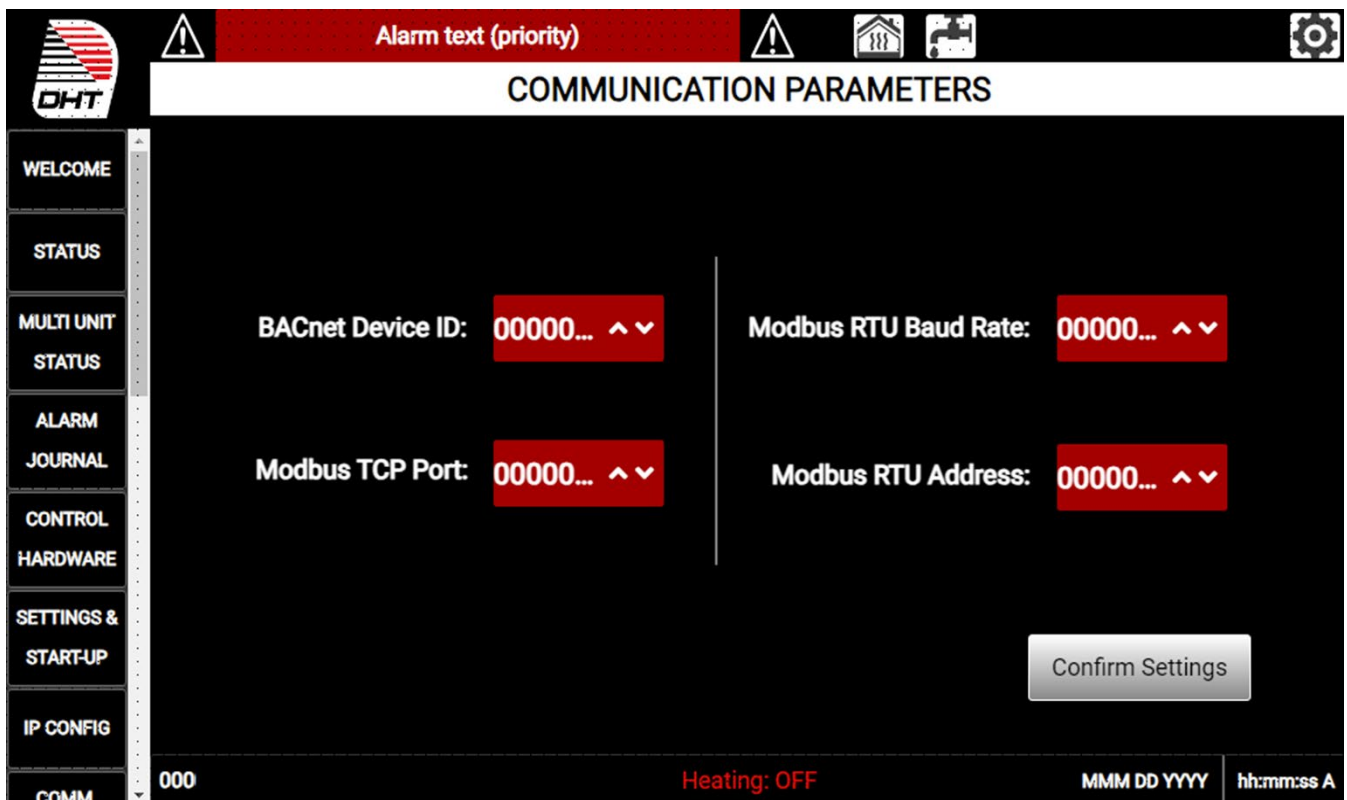



WARNING

DO NOT CHANGE INTERNAL IP ADDRESSES OR COMMUNICATION PARAMETERS UNLESS DIRECTED BY DHT/SEB OR THE SITE CONTROLS ENGINEER. INCORRECT SETTINGS CAN DISRUPT BOILER OPERATION AND BUILDING AUTOMATION CONNECTIVITY.

Mechanical & Electrical Start-Up (Summary)

Perform these steps **before** controls start-up.

1. Verify Piping and Installation

- a. Confirm the boiler is piped according to the installation drawings and instructions in the Installation section.
- b. Ensure system isolation valves and flow-restricting devices are set for proper circulation.

2. Fill and Vent the System

- c. Fill the EWx boiler and connected system with water.
- d. Bleed air from high points and the boiler to prevent air binding.
- e. Open valves and bring the system up to operating pressure.
- f. Inspect for leaks; repair any external piping leaks before proceeding.
- g. If a leak is suspected inside the boiler vessel, contact DHT/SEB.

3. Verify Power Connections

- h. Confirm all power wiring is completed according to the wiring diagrams.
- i. Have a qualified electrician verify:
 - i. High-voltage supply matches the boiler nameplate.
 - ii. Voltage is within NEC and UL limits for the specified service.
- j. If a separate 120 VAC control supply is required:
 - i. Land hot, neutral, and ground on the appropriate terminals in the Input/Output (I/O) Box.
 - ii. Verify 120 VAC is within NEC/UL limits.

4. Check Torque on Electrical Connections

- k. Verify torque on:
 - i. Fuse holders and contactors.
 - ii. Supply power block connections.

- iii. Element wiring.
- iv. Any additional field wiring in the I/O Box.
- l. Use torque values from the Electrical section of this manual.

5. Review I/O Box Connections

- m. The I/O Box is located on the exterior upper corner of the boiler, on the piping connection side.
- n. Confirm:
 - i. 120 VAC control power wiring is correct.
 - ii. Any sensor, pump, or communication wiring matches the field wiring schematic.
- o. Correct any discrepancies before proceeding.

Controls Start-Up – Powering and Initial Operation

After mechanical and electrical checks are complete:

1. Apply High-Voltage Power

- a. Close the external disconnect feeding the boiler.
- b. Verify supply voltage at the power block.

2. Apply Control Power

- c. If the unit has an internal transformer:
 - i. Control power is applied when the main disconnect is closed.
- d. If the unit requires separate 120 VAC:
 - i. Energize the 120 VAC control supply.

3. Turn on the Boiler Control Panel

- e. Press the **green POWER button** on the front door, below the touchscreen.
- f. The HMI will illuminate and begin its boot sequence (approx. 60–90 seconds).
- g. When complete, the **Welcome Screen** appears.

4. Verify Basic HMI Functions

- h. Confirm date and time on the Function Ribbon; adjust if required.
- i. Confirm the boiler number (for single-boiler systems this should read “1”).
- j. Verify there are no active alarms:
 - i. If the Alarm Notification box is present, press it and consult the Alarm Journal.

NOTE: Refer to the Controls Introduction and Overview section of this manual for a detailed description of each display, control option, and navigation path

Setup Wizard Procedures

Use the Setup Wizard to configure unit size, control function, applications, DHW parameters, multiple boiler operation, and flow options.

Accessing the Setup Wizard

1. From the Welcome or Settings screen, ensure you are logged in at Security Level 1.
2. Press the Setup Wizard button.
3. A series of pop-up windows will guide you through setup options.
4. Use:
 - NEXT to proceed.
 - BACK to return to the previous window.
 - X (top right) to exit the Setup Wizard at any time.



CAUTION

Incorrect selections can lead to improper performance. Review each window carefully and confirm values before pressing NEXT.

Figure 23– Welcome or Settings Screen

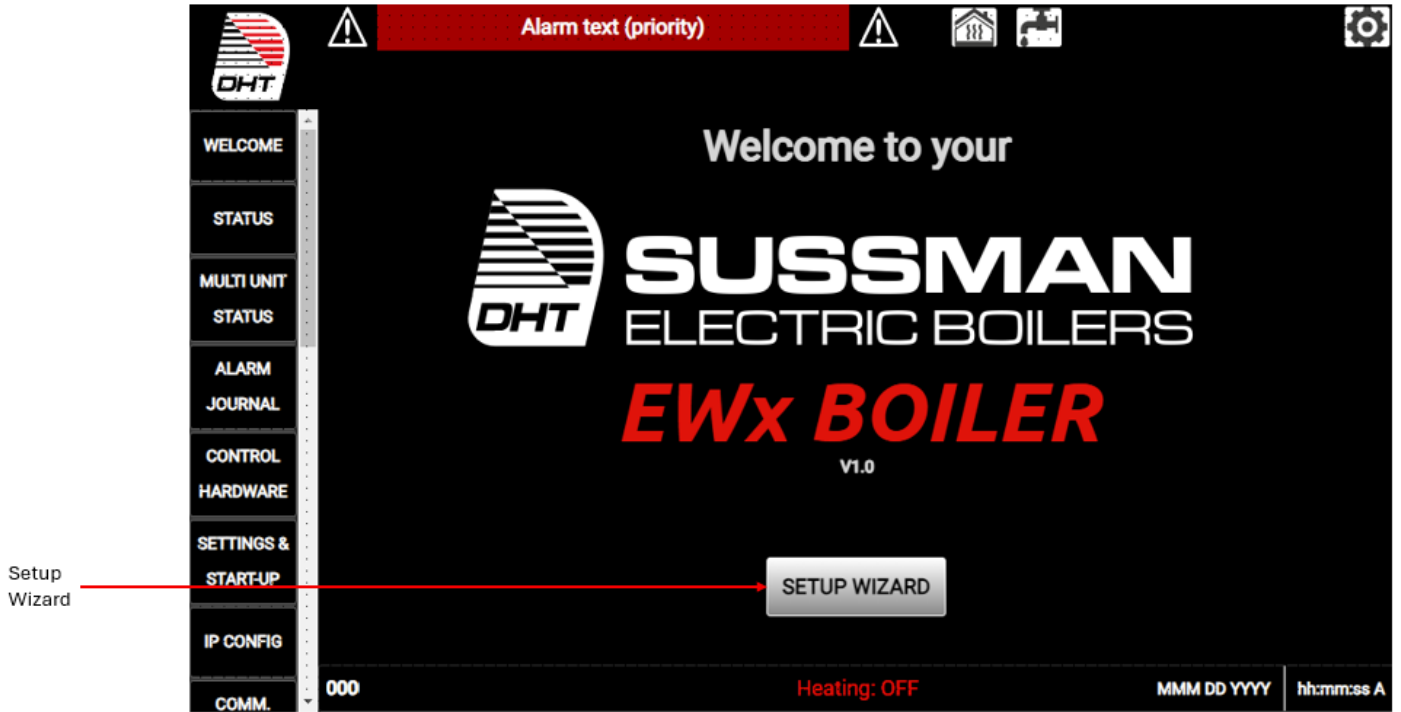

Set Up: Unit Size

1. When the SET UP: UNIT SIZE window appears:
 - a. Use the scroll wheel to select the boiler's total kW output.
 - b. The selected kW is highlighted in red.
2. Press NEXT to continue to the function selection.

Figure 23– Setup Wizard- Unit Size

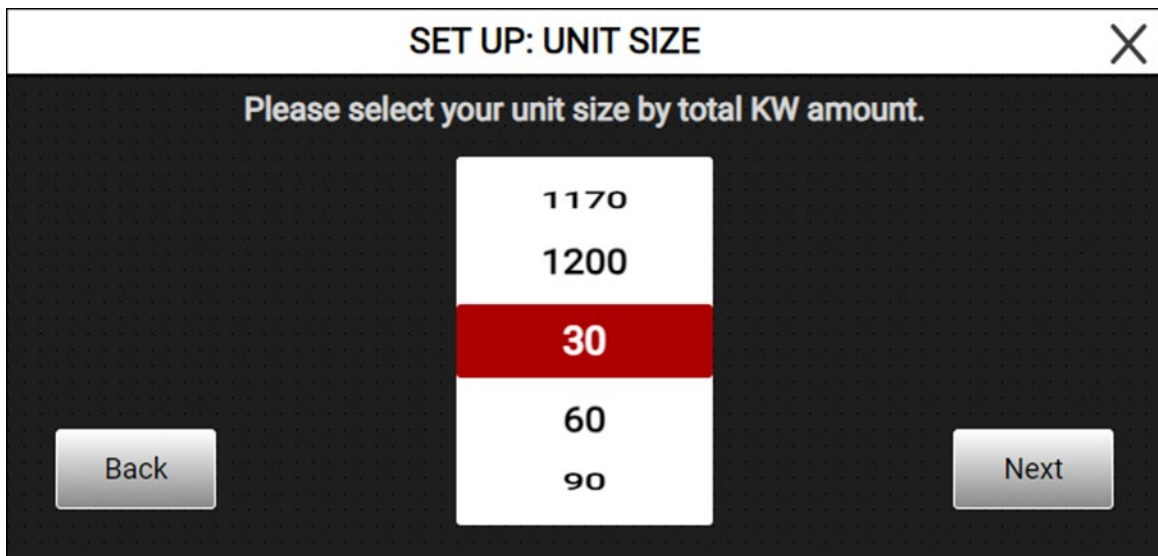

Set Up: Function – Constant Set Point vs Outdoor Reset

1. In the SET UP: FUNCTION window, choose:
 - a. CONSTANT SET POINT
 - i. Unit regulates to a single temperature set point.
 - b. OUTDOOR RESET SCHEDULE
 - i. Unit set point varies based on outdoor air temperature.
2. Press NEXT.
 - a. If Constant Set Point is selected, the SET UP: CONSTANT SET POINT window appears.
 - b. If Outdoor Reset is selected, the SET UP: OUTDOOR RESET SCHEDULE window appears.

Figure 24– Setup Wizard- Function

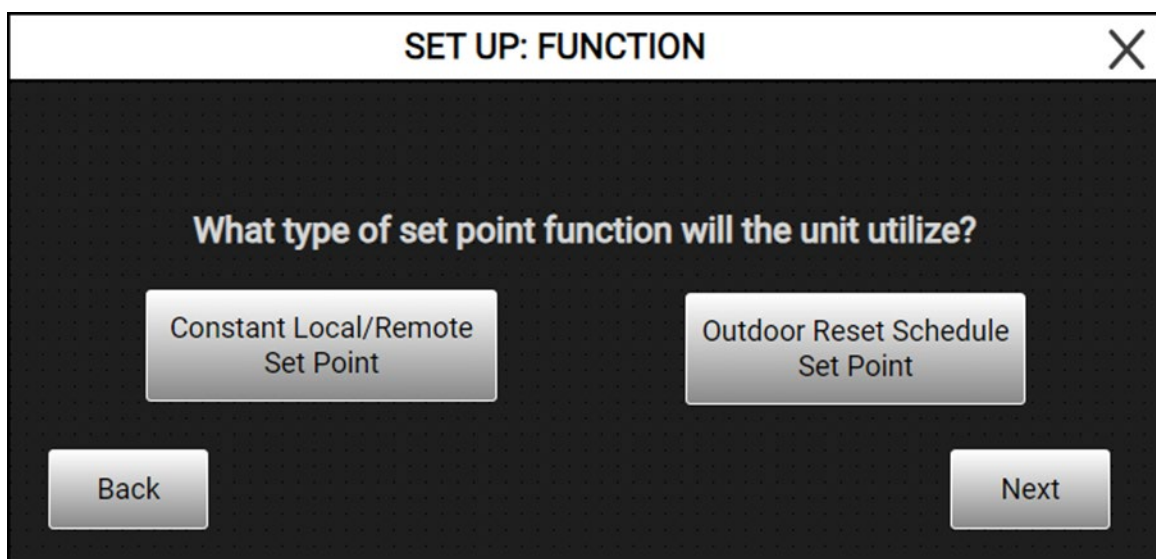

Set Up: Constant Set Point

1. In the **SET UP: CONSTANT SET POINT** window:
 - a. Set the desired **unit temperature set point** using the scroll wheel.
 - b. Under **Method of Connection**, choose one:
 - i. **LOCALLY WIRED**
 1. Inputs via the HMI and RS-485 hardwired connections (remote enable/setpoint as applicable).
 - ii. **MODBUS** (Building Automation System).
 - iii. **BACnet** (Building Automation System).
2. Press **NEXT** to continue.

NOTE: Subsequent changes to the constant set point can be made via HMI, 4–20 mA input or building automation system. Remote communication sources override local HMI changes.

Figure 24– Setup Wizard- Constant Set Point

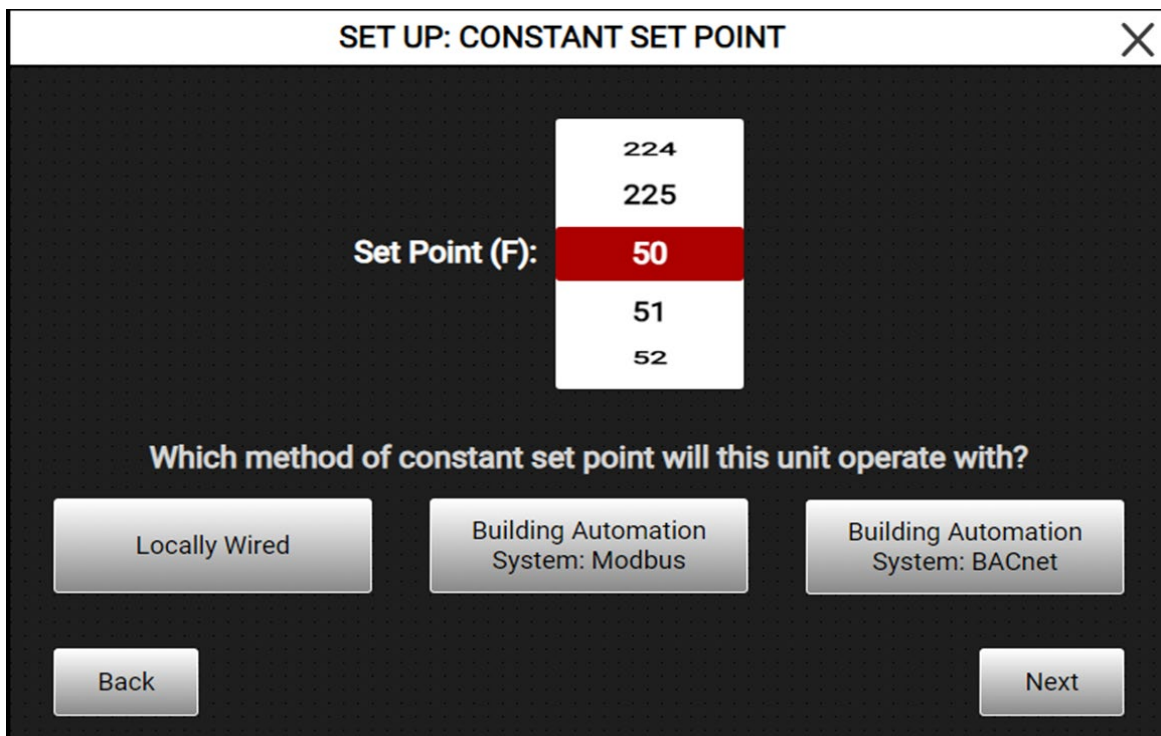

Set Up: Outdoor Reset Schedule

1. In the **SET UP: OUTDOOR RESET SCHEDULE** window:
 - a. Review the graph showing boiler set point vs outdoor air temperature.
 - b. Use the red input boxes to set:
 - i. **High Outdoor Air Temperature.**
 - ii. **Low Outdoor Air Temperature.**
 - iii. **High Boiler Set Point.**
 - iv. **Low Boiler Set Point.**
 - c. As values are adjusted, the graph updates automatically.
 - d. If desired, press the **Factory Default** button to restore default reset curve values.
 - e. Under **Method of Connection**, select:
 - i. **LOCALLY WIRED, MODBUS, or BACnet** (as above).
2. Press **NEXT** to continue.

NOTE: When Outdoor Reset is active, the reset schedule set point takes precedence over the constant set point. If the outdoor sensor fails or reads out-of-range values, the boiler will revert to Constant Set Point mode.

Figure 24– Setup Wizard- Outdoor Reset

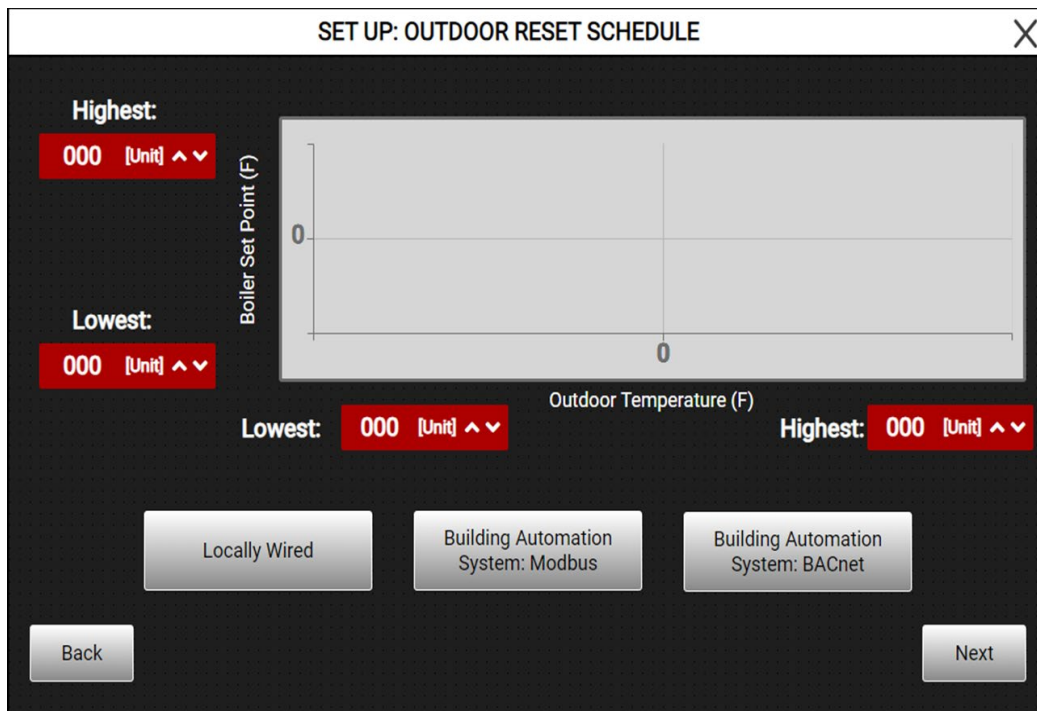

Set Up: Application (Space Heating and/or DHW)

1. In the SET UP: APPLICATION window:
 - a. Select one of the following heating applications:
 - i. Space Heating Only
 - ii. DHW Tank Only
 - iii. Space Heating + DHW Tank
2. Press NEXT to proceed.

NOTE: The specific piping, sensor installation, and pump wiring for each application must be completed per the Installation section before controls start-up.

Figure 25– Setup Wizard- Application

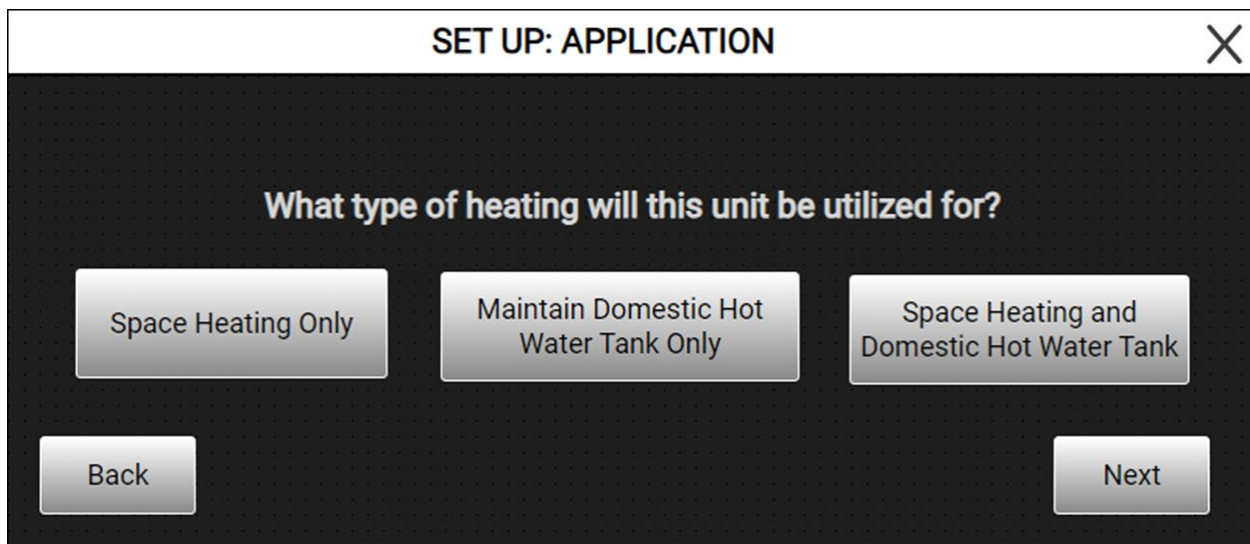

Set Up: Domestic Hot Water Application

If either DHW option was selected, the **SET UP: DOMESTIC HOT WATER APPLICATION** window appears.

1. Set DHW parameters:
 - a. **DHW Tank Set Point**
 - i. Desired tank temperature (e.g., 140°F).
 - b. **DHW Tank Dead Band**
 - i. Acceptable temperature swing around set point.
 - ii. Example: Set point = 140°F, dead band = 10°F:
 1. Heating stops above 150°F.
 2. Heating resumes below 130°F.
 - c. **EWx Boiler Set Point in DHW Mode**
 - i. Select boiler set point used while in DHW operation, if different from space heating.
 - ii. Or select “Leave set point at normal operating temperature” if the boiler should use the same set point for both modes.
2. Press **NEXT** or close the window when parameters are correct.

Figure 25– Setup Wizard- Domestic Hot Water Application

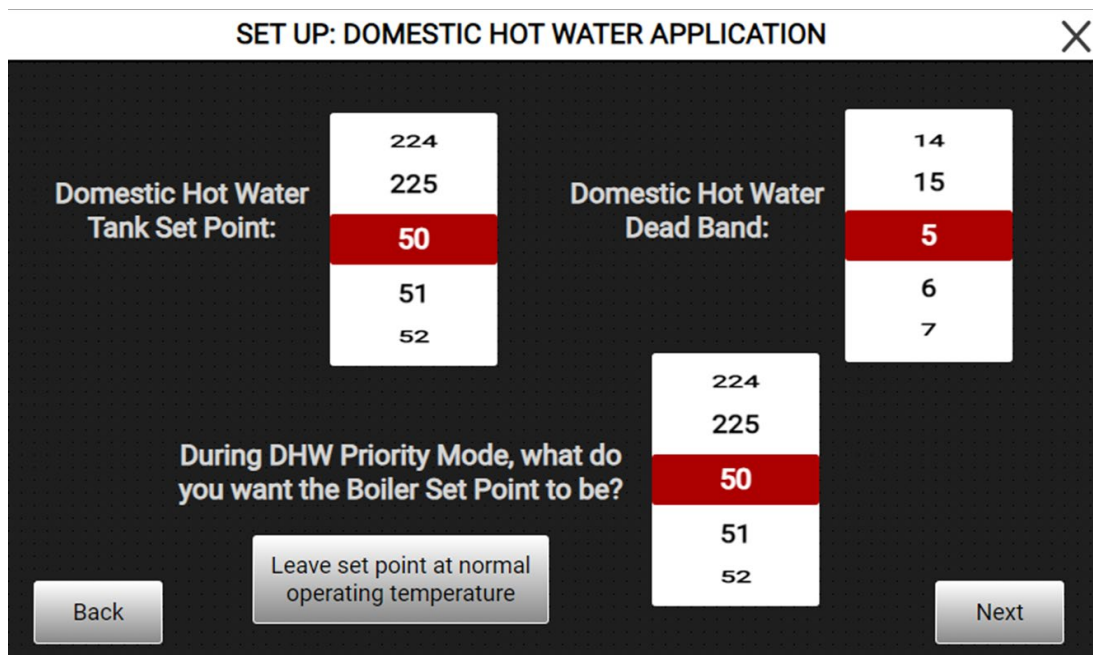

SET UP: DOMESTIC HOT WATER APPLICATION [X]

Domestic Hot Water Tank Set Point: 224, 225, **50**, 51, 52

Domestic Hot Water Dead Band: 14, 15, **5**, 6, 7

During DHW Priority Mode, what do you want the Boiler Set Point to be? 224, 225, **50**, 51, 52

Back [Leave set point at normal operating temperature] Next

Set Up: Multiple Boiler Application

In the **MULTIPLE BOILER APPLICATION** window:

- a. Select YES if the unit is part of a multiple EWx boiler system.
- b. Select NO if this is a standalone boiler.

Figure 26– Setup Wizard- Multiple Boiler Application

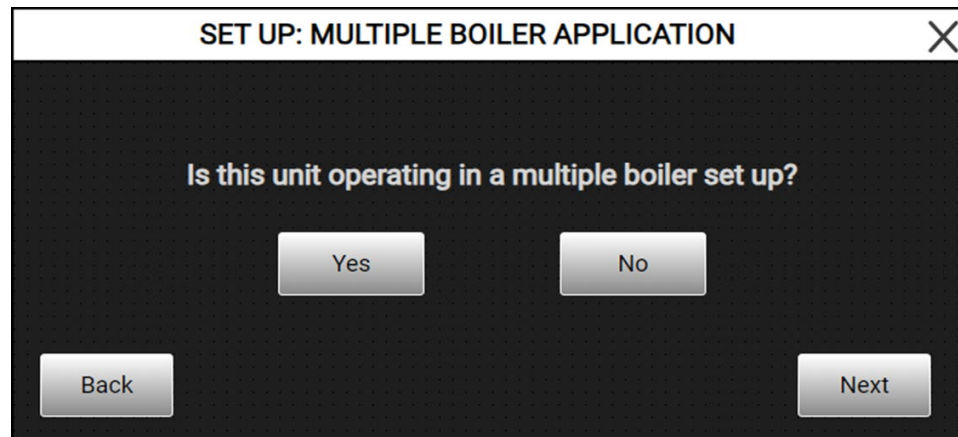

2. If **YES** is selected:
 - a. The **SET UP: MULTI-UNIT TYPE** window appears:
 - i. Choose **PRIMARY BOILER** for the lead unit.
 - ii. Choose **SECONDARY BOILER** for follower units.

Figure 27– Setup Wizard- Multiple Unit Type

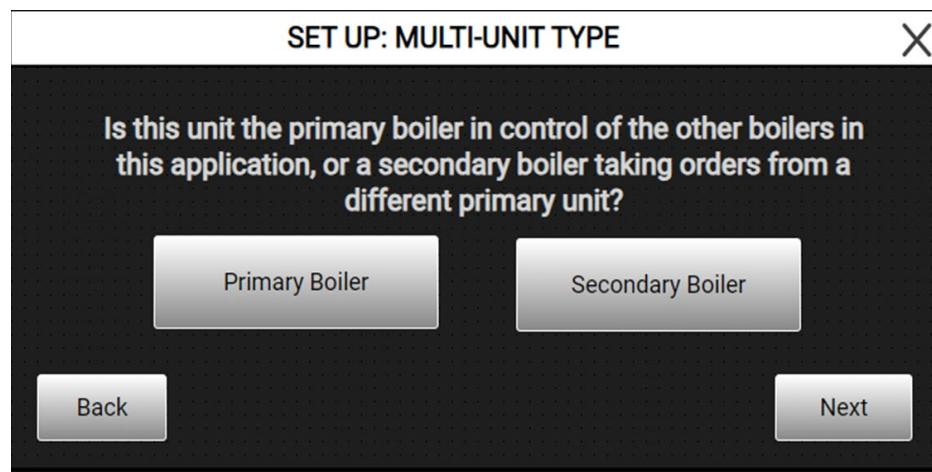

Set Up: Primary Unit

If **PRIMARY BOILER** is selected:

1. In the **SET UP: PRIMARY UNIT** window:
 - a. Use the scroll wheel to select the **Total number of EWx boilers** in the system (including the primary).
 - b. Confirm the boiler number in the lower left corner reads “1”.
2. Press **NEXT** to continue.

Figure 28– Setup Wizard- Primary Unit

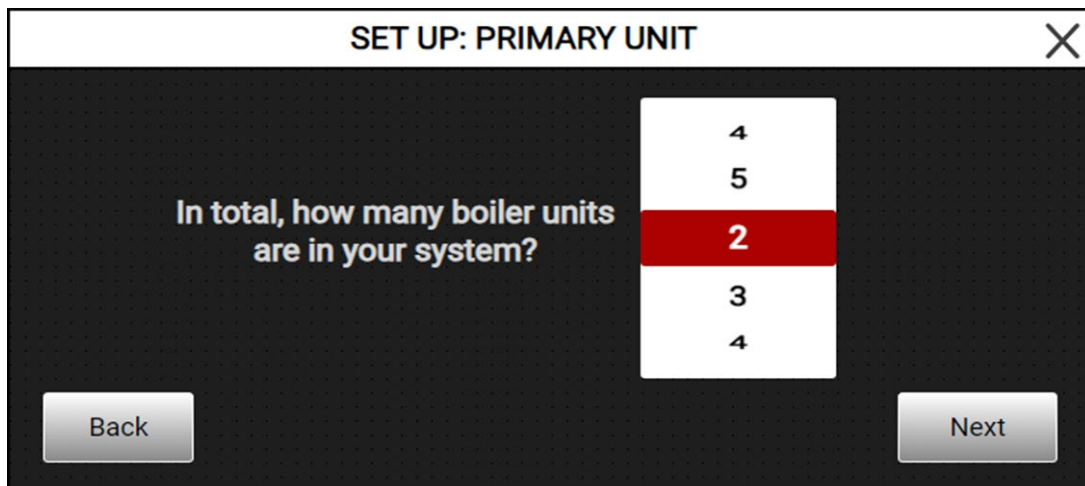

Set Up: Secondary Unit

If **SECONDARY BOILER** is selected:

1. In the **SET UP: SECONDARY UNIT** window:
 - a. Use the scroll wheel to assign a **unique boiler number** (2, 3, 4, etc.).
2. **Important:** After selecting the number, do **not touch the screen** until:
 - a. The temporary “Websocket” popup disappears.
 - b. The boiler number appears in the lower left corner of the HMI.
 - c. During this time, the system is reprogramming IP addresses based on the selected boiler number.
3. Verify each secondary boiler has a unique number before connecting inter-boiler communication cables.

 **WARNING**

ASSIGNING DUPLICATE BOILER NUMBERS OR INTERRUPTING THE IP REPROGRAMMING SEQUENCE MAY CAUSE COMMUNICATION FAILURE AND REQUIRE CONTROLLER REPROGRAMMING.

Figure 29– Setup Wizard- Secondary Unit

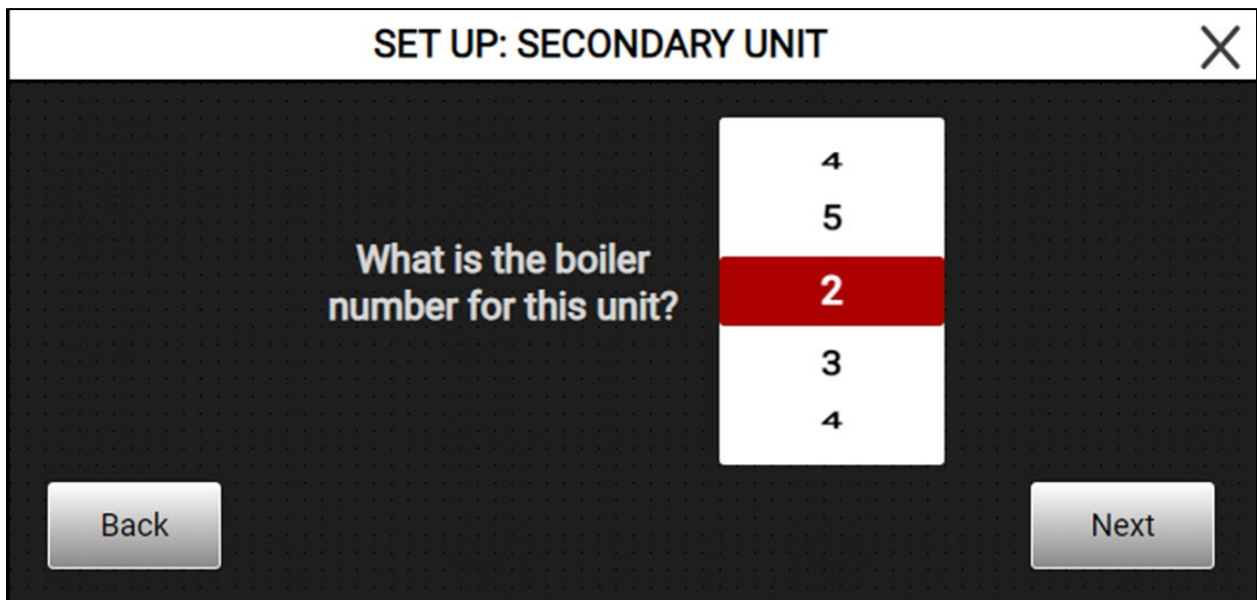

Set Up: Flow

1. In the **SET UP: FLOW** window:
 - a. Indicate whether the boiler loop includes:
 - i. A **flow switch**.
 - ii. A **flow meter**.
 - iii. A **header temperature sensor**.
 - b. Use the YES/NO icons to match installed equipment.
2. Press **NEXT** to finish the Setup Wizard.

Figure 30– Setup Wizard- Additional Equipment

SET UP: ADDITIONAL EQUIPMENT X

Will this unit operate using a Flow Switch?

Yes No

Will this unit operate using a Flow Meter?

Yes No

Will this unit employ a Header Temperature Sensor?

Yes No

Back FINISH SET UP

Application-Specific Start-Up

Constant Set-Point Operation

1. Confirm the unit has been configured for **Constant Set Point** via Setup Wizard.
2. Verify the desired set point on the Status screen or modify via:
 - a. HMI.
 - b. 4–20 mA analog input (if wired).
 - c. Building automation system (Modbus or BACnet), if configured.
3. Ensure any remote enable/disable circuits are wired correctly and enabled.
4. Place the boiler in normal operating mode (Manual Mode OFF).
5. Verify heating operation as the unit modulates to the target set point.

Outdoor Reset Schedule Operation

1. Confirm the outdoor temperature sensor is installed and wired per the Installation section.
2. Verify the **Outdoor Reset** function is enabled in the Setup Wizard.
3. Confirm high/low outdoor and high/low set point values on the Outdoor Reset Schedule window.
4. View the outdoor reset graph on:
 - a. Setup Wizard screen, or
 - b. Alternate layout of the Status screen (via **Switch Display** button).
5. Place the boiler in normal operating mode and monitor that set point varies with outdoor temperature.

NOTE

If the outdoor sensor fails or reads abnormally, the boiler automatically reverts to the Constant Set Point temperature established in setup.

Space Heating-Only Applications

1. Confirm:
 - a. Piping and pumps are installed per the Installation section for space heating service.
 - b. Any flow equipment (switch/meter) is correctly wired and configured.
2. Access the **Setup Wizard** and verify:
 - a. **Application** is set to **Space Heating Only**.
 - b. Desired control mode (Constant Set Point or Outdoor Reset) is correctly selected.
3. Confirm the system pump is enabled and has adequate flow.
4. Place the boiler into normal operation and monitor:
 - a. Outlet temperature.

- b. Inlet temperature.
- c. Element map and kW output.
5. Check for stable operation at the desired space heating set point.

DHW Applications (DHW-Only or Space Heating + DHW)

1. Verify installation:
 - a. DHW tank temperature sensor is installed in the tank at an appropriate location.
 - b. DHW system pump is wired to the proper terminals in the I/O Box.
2. In the **Setup Wizard**:
 - a. Confirm **Application** is set to **DHW Tank Only** or **Space Heating + DHW**.
 - b. In **SET UP: DOMESTIC HOT WATER APPLICATION**, verify:
 - i. DHW Tank Set Point.
 - ii. DHW Dead Band.
 - iii. Boiler set point for DHW mode (or “normal operating temperature” selection).
3. Place the boiler into normal operation.
4. Use the **Status display** and **Switch Display** button to view the DHW system graphic:
 - a. DHW pump icon turns green when energized.
 - b. Piping turns red when hot water is flowing.
 - c. Tank icon shows tank temperature and changes color based on set point satisfaction.
5. Confirm the DHW tank heats to and maintains the desired temperature.

Multiple Boiler Applications

Important Pre-Steps

1. Ensure all units:
 - a. Are installed and wired per their respective mechanical and electrical start-up instructions.
 - b. Have completed the Setup Wizard individually with correct application and function settings **before connecting Ethernet between units**.
2. In each boiler’s I/O Box, locate **Ethernet Switch #1**:
 - a. Top two ports are factory-wired for internal HMI/PLC communication – **do not disturb**.
 - b. Any field communication cables for multi-unit operation should be **disconnected** during initial setup.

Configuration Steps

1. For **each boiler**, access the Setup Wizard and:
 - a. Complete all standard settings (Function, Application, DHW, Flow, etc.).
 - b. In **MULTIPLE BOILER APPLICATION** window, choose **YES**.
 - c. In **MULTI-UNIT TYPE**:

- i. Select **PRIMARY BOILER** for the lead unit (only one per system).
 - ii. Select **SECONDARY BOILER** for all others.
2. For the **Primary Boiler**:
 - a. Set total number of boilers in **SET UP: PRIMARY UNIT**.
3. For each **Secondary Boiler**:
 - a. In **SET UP: SECONDARY UNIT**, assign a unique boiler number (2, 3, ...).
 - b. Wait while the HMI reprograms the IP address (Websocket popup disappears, number appears in corner).
4. After all units are configured and assigned:
 - a. Reconnect the multi-unit Ethernet IP cables to **Ethernet Switch #1** (per wiring diagram).
 - b. On the Primary Boiler, open the **Multi Unit Status** display:
 - i. Confirm all boilers are listed.
 - ii. Check connection status and outlet temperatures.

NOTE: The Primary Boiler manages set point and mode for all connected Secondary Boilers. Changes to set point on the Primary propagate throughout the system.

Remote Unit Control and Communications

The EWx can be integrated with building automation systems using **BACnet** or **Modbus** and can also be controlled via **remote enable/disable** and **remote analog set point**.

Wiring Considerations

1. Wire all communication and remote control circuits to the I/O Box terminals per the field wiring schematic.
2. For **Remote Enable/Disable** using a dry contact:
 - a. Remove the jumper between:
 - i. 24 VDC terminal on Ethernet Switch #2 and
 - ii. Terminal #3 in the I/O Box.
 - b. Use the 24 VDC terminal as the source for the enable/disable loop if required.
3. For **BACnet or Modbus** over Ethernet:
 - a. Land the communication cable in **Ethernet Switch #2** in the I/O Box at any open port.
 - b.

Selecting Communication Type in Setup Wizard

1. In the **SET UP: FUNCTION** sequence (Constant Set Point or Outdoor Reset):
 - a. Choose the appropriate **Method of Connection**:
 - i. **LOCALLY WIRED**

ii. **MODBUS**

iii. **BACnet**

2. Press **NEXT** and complete the remaining setup windows.

Configuring Communication Parameters

1. Log into **Security Level 2**.
2. Open the **COMM. PARAMS.** display:
 - a. Set:
 - i. BACnet Device ID.
 - ii. Modbus TCP Port.
 - iii. Modbus RTU Baud Rate.
 - iv. Modbus RTU Address.
 - b. Press **Confirm Settings** to save.
3. Open the **IP CONFIG** display:
 - a. Change only **HMI Port 2** IP address as required by the building automation network.
 - b. Press **Set IP** to save.

WARNING

Do not alter other IP ports or controller addresses unless directed by DHT/SEB or a qualified controls engineer. Incorrect settings can cause loss of communication and boiler control.

Basic Use of Diagnostic Screens

During commissioning or troubleshooting:

Alarm Journal

1. Investigate any active alarms and correct causes.
2. Use timestamps to correlate alarms with system events.

Figure 30– Alarm Journal Display

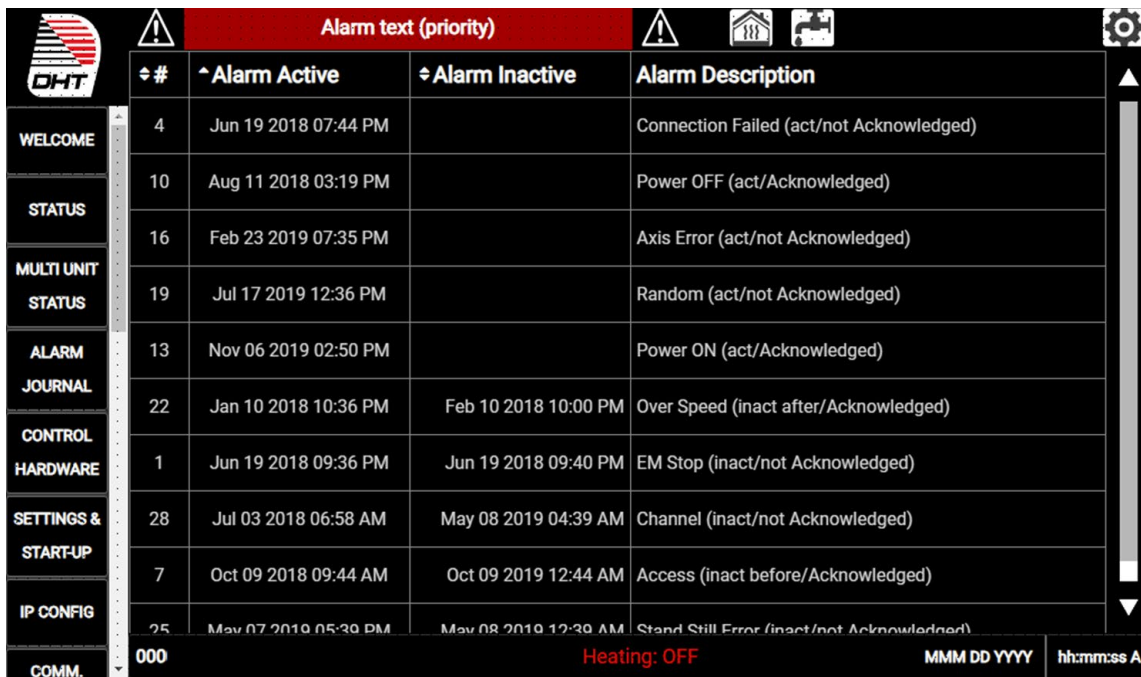

		Alarm text (priority)			
#	Alarm Active	Alarm Inactive	Alarm Description		
4	Jun 19 2018 07:44 PM		Connection Failed (act/not Acknowledged)		
10	Aug 11 2018 03:19 PM		Power OFF (act/Acknowledged)		
16	Feb 23 2019 07:35 PM		Axis Error (act/not Acknowledged)		
19	Jul 17 2019 12:36 PM		Random (act/not Acknowledged)		
13	Nov 06 2019 02:50 PM		Power ON (act/Acknowledged)		
22	Jan 10 2018 10:36 PM	Feb 10 2018 10:00 PM	Over Speed (inact after/Acknowledged)		
1	Jun 19 2018 09:36 PM	Jun 19 2018 09:40 PM	EM Stop (inact/not Acknowledged)		
28	Jul 03 2018 06:58 AM	May 08 2019 04:39 AM	Channel (inact/not Acknowledged)		
7	Oct 09 2018 09:44 AM	Oct 09 2019 12:44 AM	Access (inact before/Acknowledged)		
25	May 07 2019 05:30 PM	May 08 2019 12:39 AM	Stand Still Error (inact/not Acknowledged)		
000		Heating: OFF		MMM DD YYYY hh:mm:ss A	

Control Hardware Display

1. Confirm all control modules appear normal.
2. Cross-check with wiring diagram if a module is not responding.

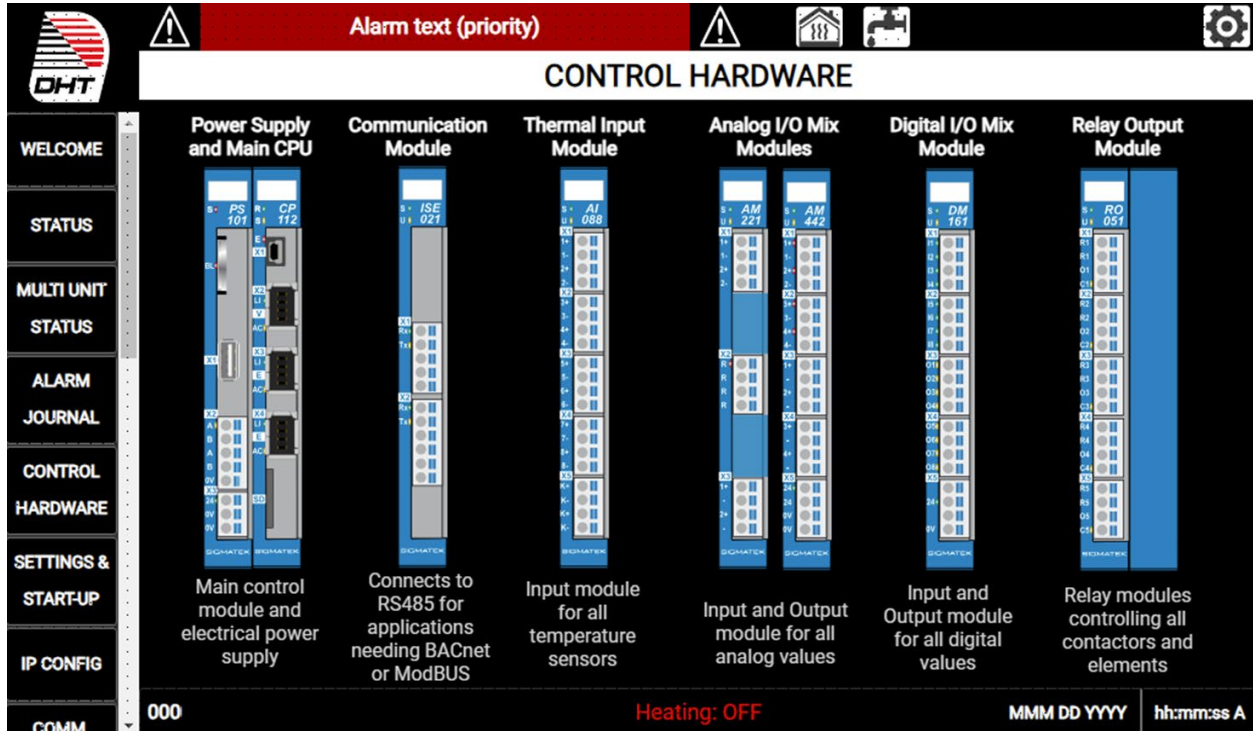
Figure 30– Control Hardware Display

Testing/Troubleshooting

- a. Use Manual Mode and toggles to verify pump and fan operation, flow switch behavior, and call for heat signals.
- b. Exit Manual Mode promptly after testing.

Contactor Control

- c. With Manual Mode ON and appropriate safety precautions taken, energize contactors individually to:
 - i. Measure current.
 - ii. Confirm contact closure.
- d. Allow toggles to time out or turn them off manually after testing.

Figure 31– Testing/ Troubleshooting- Contractor Control Display

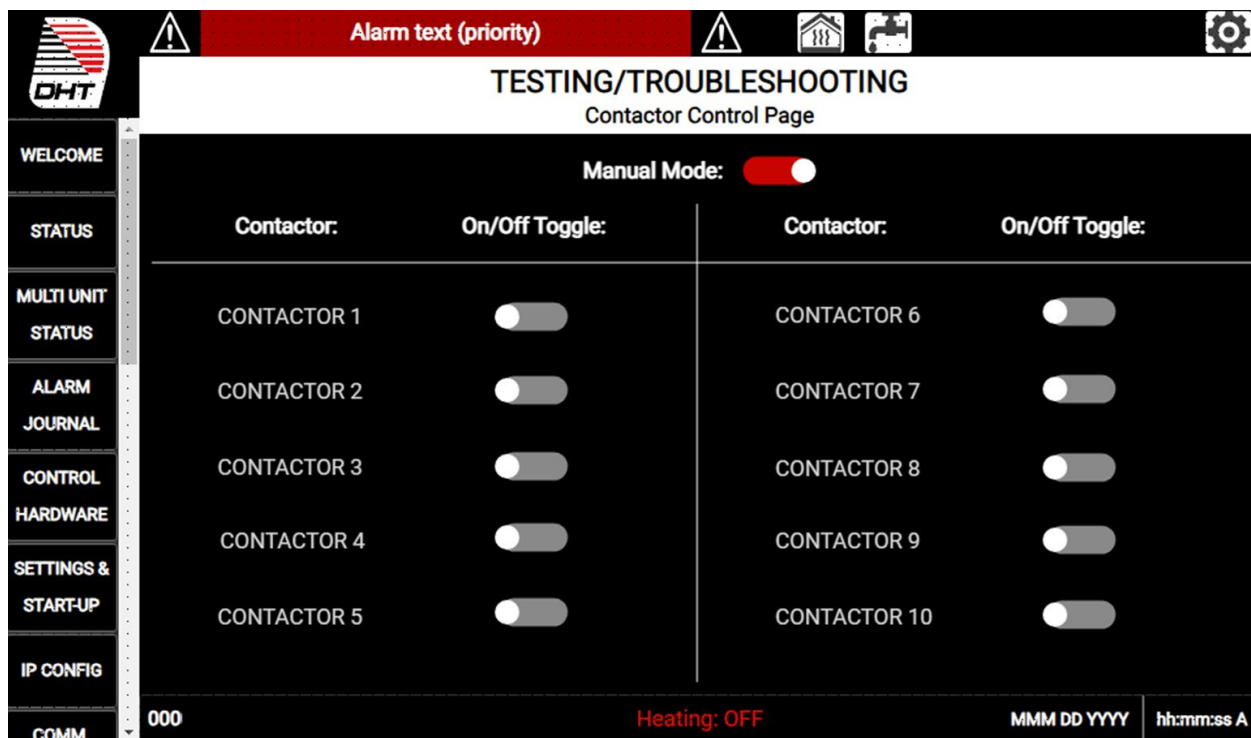

PID Control

Only adjust if system shows poor modulation and you have direction from DHT/SEB or a controls engineer. Otherwise, use Autotune with guidance.

Figure 32– PID Setup Display

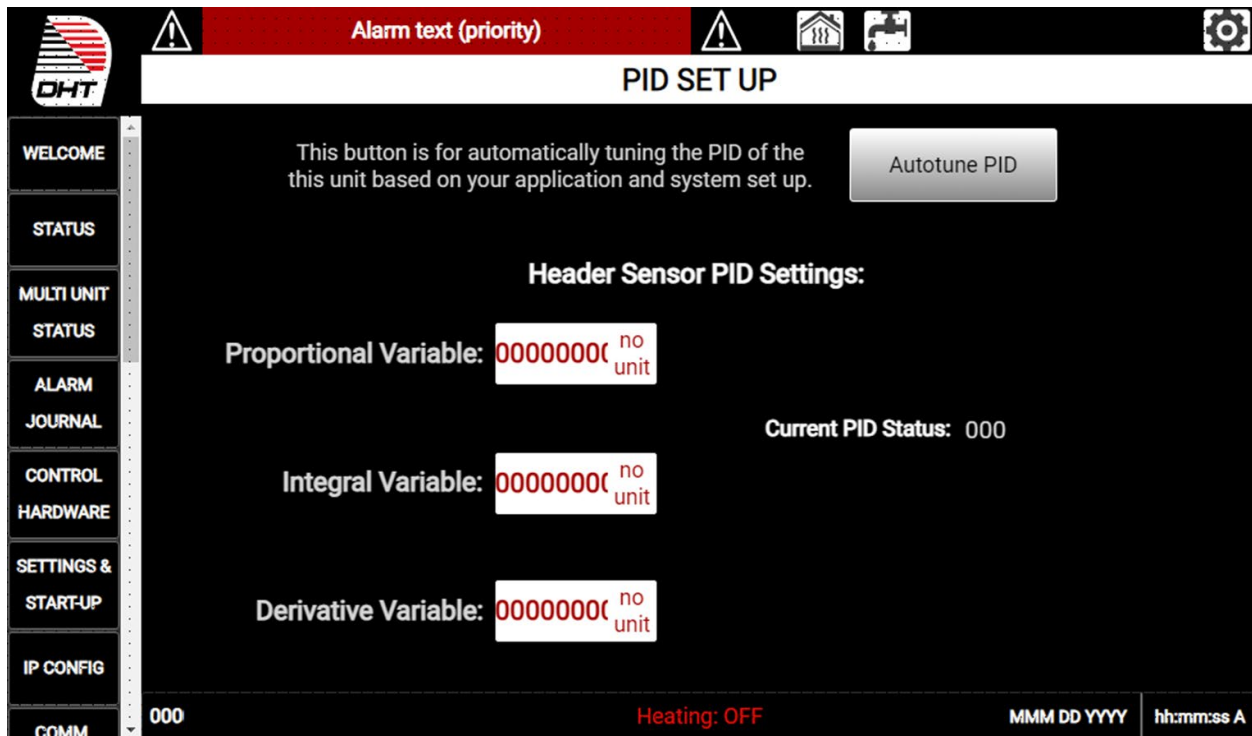

Figure 33– Modbus/BACnet Data Addresses and Points

Modbus/BACnet Data Addresses and Points					
Item Description	Type	Modbus Address	BACnet Address	Register	Comments
Space Heating Boiler Remote/Local Setpoint	DINT	2	AV #1	RW	100°F-230°F Range
Outdoor Temperature Ratio High	REAL	4	AV #2	RW	-50°F -120°F Range
Outdoor Temperature Ratio Low	REAL	6	AV #3	RW	-50°F -120°F Range
Outdoor Reset Boiler Temperature High	REAL	8	AV #4	RW	100°F-230°F Range
Outdoor Reset Boiler Temperature Low	REAL	10	AV #5	RW	100°F-230°F Range
Domestic Hot Water Boiler Setpoint	DINT	12	AV #6	RW	0°F-230°F Range
Domestic Hot Water Tank Setpoint	DINT	14	AV #7	RW	0°F-200°F Range
Domestic Hot Water Tank Dead Band	DINT	16	AV #8	RW	0-15 Range
Boiler Outlet Temperature	DINT	18	AI #1	RO	
Boiler Inlet Temperature	DINT	20	AI #2	RO	
SCR Control Value	DINT	22	AI #3	RO	
PID Output %	DINT	24	AI #4	RO	
kW Output	UDINT	26	AI #5	RO	
Flow Meter Value	DINT	28	AI #6	RO	
Elements Active/On	UDINT	30	AI #7	RO	
System Status	UDINT	32	AI #8	RO	
Electrical Panel Temperature	DINT	34	AI #9	RO	
Domestic Hot Water Tank Temperature	DINT	36	AI #10	RO	
Outdoor Temperature	DINT	38	AI #11	RO	
Active Alarms	DINT	40	AI #12	RO	0-100 Range

Notes:

Abbreviations: RO – Read Only, RW – Read/Write, AV – Analog Value, AI – Analog Input, BI – Binary Input

Section 6- Maintenance & Troubleshooting

IMPORTANT SAFETY NOTICES



THIS SECTION IS FOR REFERENCE AND GUIDANCE ONLY AND DOES NOT REPLACE REQUIRED PROFESSIONAL TRAINING OR COMPLIANCE WITH APPLICABLE CODES AND REGULATIONS. MAINTENANCE MUST BE PERFORMED BY QUALIFIED PERSONNEL.

WARNING: ELECTRICAL SHOCK AND ARC FLASH HAZARD

Before any maintenance involving electrical components, disconnect all electrical supplies to the boiler. Follow lockout tagout procedures. Verify absence of voltage with a properly rated meter before touching conductors or components.

WARNING: HOT WATER AND PRESSURE HAZARD

Ensure the boiler is off, cooled, and the hydronic system is depressurized as required before opening any components. Wear appropriate PPE.



After initial start-up by qualified personnel, control settings should not be changed except by trained service personnel or as directed by Sussman Electric Boilers or your authorized representative.

All maintenance procedures should be completed by trained personnel. To maintain warranty coverage, document and perform all maintenance activities at the recommended intervals.

General Maintenance Philosophy

The EWx boiler is designed for reliable long term service. Consistent inspection and preventive maintenance help ensure safety, efficient operation, and reduced downtime.

Good practice includes:

- Routine Daily, Monthly, and Annual checks
- A system level review after any service action
- Documented service history (dates, readings, alarms, corrective actions)

System Review Items

During routine inspections, look for:

- Discoloration on jacket panels or nearby painted equipment (possible overheating or airflow issues)
- Evidence of leaks at the boiler, piping, pumps, valves, strainers, and relief valve discharge piping
- Signs of corrosion, mineral buildup, or staining around flanges and unions
- Unusual vibration or noise from pumps, valves, or piping supports
- Adequate clearances and ventilation around the boiler and electrical panels
- Water quality issues (cloudiness, odor, sludge, recurring air)

Housekeeping and Environment



CAUTION

Do not allow dust or dirt to accumulate on or around the boiler. Dust buildup in electrical compartments can lead to overheating and nuisance faults.

- Keep the area clear of combustibles, flammable vapors, and liquids.
- Keep ventilation openings unobstructed.
- Maintain a dry environment. Moisture can affect electrical insulation resistance and electronics.

Tools and Supplies

A qualified service technician should have these tools and supplies available.

Recommended Tool List

- Digital Multimeter (DMM), minimum CAT III-600 V rated for the installation
- Insulation resistance tester (megohmmeter or “megger”) rated for the system voltage

- Calibrated torque wrench
- Calibrated torque screwdriver (with appropriate bits, including metric hex if required)
- Standard hand tools
 - Insulated screwdrivers (flat and Phillips)
 - Socket sets (metric and SAE as applicable)
 - Adjustable wrench, pipe wrenches
 - Allen/hex key sets
- Nonconductive cleaning supplies
 - Lint free wipes
 - Electrical contact cleaner approved for use on electrical assemblies
- Consumables
 - Dielectric grease (electrical grade)
 - Anti seize (electrical grade for approved fasteners)
 - Threadlocker (medium strength, as needed where specified)
 - Replacement gaskets as required by service procedure
- PPE
 - Arc rated clothing per site requirements
 - Safety glasses or face shield
 - Insulated gloves as required
- Lockout Tagout devices and tags
- Maintenance checklist form and writing instrument

Maintenance Schedule Overview

This schedule is a baseline. Your actual frequency may need to be more frequent depending on water quality, duty cycle, and site conditions.

Daily Inspection Schedule

- 1. Observe operating temperatures and general condition**
 - a. Confirm stable inlet and outlet temperatures and expected load behavior.
 - b. Confirm no active alarms on the HMI.
- 2. Check ventilation and cabinet temperature**
 - a. Ensure airflow is not obstructed.
 - b. Confirm electrical cabinet temperature is within normal operating range.
- 3. Check area safety**
 - a. Boiler area clear of combustibles.

- b. No flammable vapors or liquids present.
- 4. Quick leak check**
 - a. Scan for water at piping joints, relief valve discharge, pump flanges, and isolation valves.

Monthly Inspection Schedule

- 1. Test safety controls and operating limits**
 - a. Verify high limit and operating control functions using approved test procedures for your site.
 - b. Confirm that any manual reset limits are set above the normal operating setpoint and control differential.
- 2. Verify pumps and flow proving**
 - a. Confirm system pump operation.
 - b. Verify flow switch or flow meter (if equipped) indicates proper flow.
- 3. Review alarm history**
 - a. Use the Alarm Journal to identify repeat alarms or trends.
- 4. Inspect electrical compartment condition**
 - a. With power locked out, inspect for dust buildup, discoloration, loose conductors, or heat damage.

Annual Maintenance Schedule

Annual maintenance should be performed by a qualified, authorized technician and documented.

- 1. Electrical inspection**
 - a. Inspect control panel and power compartment for debris and secure mounting.
 - b. Check for overheating indicators (discoloration, odor, insulation damage).
- 2. Verify wiring integrity**
 - a. Confirm torque on critical electrical connections per the Torque Values table in Section 6 *Figure 34* of the EWx IOM.
- 3. Element and contactor evaluation**
 - a. Confirm staged operation and contactor condition.
 - b. Inspect for signs of contactor wear or arcing.
- 4. Hydronic system inspection**
 - a. Inspect strainers, expansion tank operation, air separators, pump performance, and valve function.
 - b. Review water chemistry and treatment program.
- 5. Safety device testing**

- a. Verify correct operation of temperature limits, flow proving, and any low water or external safeties (as equipped).
- 6. Relief valve inspection and test**
 - a. Follow the relief valve manufacturer's instructions. Replace if leaking or if it fails to seat properly.
- 7. Controls and communications verification**
 - a. Confirm HMI time, alarms, sensor readings, and modulation.
 - b. Verify BAS connectivity (BACnet or Modbus) if used.
- 8. Firmware and configuration review**
 - a. Update software or firmware only when directed by Sussman Electric Boilers or when required for multi boiler integration consistency.
 - b. For lead lag systems, ensure all units are on the same approved revision and configuration.

Electric Heating Element and Power Train Maintenance

Grounding and Bonding

- Confirm the equipment grounding conductor and bonding connections are properly installed and in good condition.
- Perform a ground continuity test if required by site procedures.

General Electrical Safety for Service



ARC FLASH HAZARD

Large available fault current may be present. Use appropriate PPE and follow site arc flash requirements. Do not open electrical enclosures unless the unit is de energized and locked out.

Connection Torque Guidance

All electrical connections must be tightened to the values specified in the per the Torque Values in the below chart.

CAUTION

Do not apply generic torque values if the EWx drawings specify different values. Over torque or under torque can cause overheating, arcing, or loose connections.

Figure 34– Torque Values

TORQUE VALUES		
Mechanical:		
Element Flange Nuts (5/16"-18, Grade B7)	22 LB-FT	29.8 NM
Electrical:		
Element Terminal Nuts	20 LB-IN	2.26 NM
Contactors, Fuse Blocks, Power Blocks Load Side - #6 AWG Wire	45 LB-IN	60.01 NM
Power Blocks Line Side - #8 AWG Wire	25 LB-IN	2.82 NM
Power Blocks Line Side - #6 AWG & #4 AWG Wire	45 LB-IN	5.08 NM
Power Blocks Line Side - #3 AWG to 3/0 AWG Wire	50 LB-IN	5.65 NM
Power Blocks Line Side - 4/0 AWG to 250 KCMIL Wire	50 LB-IN	5.65 NM
Power Blocks Line Side - 350 KCMIL Wire	50LB-IN	5.65 NM
Power Blocks Line Side - 500 to 1000 KCMIL Wire	50LB-IN	5.65 NM
Ground Blocks Line Side - #8 AWG Wire	25 LB-IN	2.82 NM
Ground Blocks Line Side - #6 AWG & #4 AWG Wire	45 LB-IN	5.08 NM
Ground Blocks Line Side - #3 AWG to #1 AWG Wire	50 LB-IN	5.65 NM

Gaskets

- **Do not reuse element or access cover gaskets.**
- Once a gasket has been compressed and then disturbed, replace it.
- Ensure all gasket surfaces are clean and dry before reassembly.

Instructions for Element Replacement

Before installing your new elements be sure the auxiliary low water cutoff is operating properly. Failure to do this may cause the immediate burn-out of the new elements. The manufacturer cannot be responsible for burn-outs caused by a faulty low water cutoff.

1. Disconnect the boiler from electric power supply at main safety switch or fuse panel. Then turn boiler switch to "OFF" position.
2. Close inlet (return) and outlet (supply) water valves. Drain boiler completely of water.
3. Open boiler door and remove the element shrouds to access heating elements.
4. Disconnect wire (electric) leads connecting element to main power system of boiler. Note wire connections to facilitate re-assembly. Proceed to remove and discard (6) element flange nuts.
5. Thoroughly clean boiler flange of all foreign material. Be certain no part of old gasket remains on flange.
6. Proceed to install element flange assembly with gasket between boiler flange and element flange. In doing this, be careful to align flange holes so element wire connection terminals on element assembly are in line with previously disconnected wire leads to facilitate easy connections.
7. Use only new element flange nuts. Tighten all (6) element flange nuts to a torque value of 22 ft-lb each.
8. Connect all wires to the terminals. Tighten all element terminals to a torque value of 20 lb.-in each (ensure each nut holding the bus bars in place are torqued to 20 lb.-in). Make sure all wires are clean and bright to ensure good electrical contact.
9. Check that the wires are correctly connected to the contactor terminals and are tightened to a torque of 45 lb-in. Make sure all wires are clean and bright to ensure good electrical contact.
10. Open water valves to allow water supply to fill the boiler.
11. As boiler automatically refills, observe the new flange assembly for possible leaks. If water is noticed, the bolts must be re-tightened.
12. When boiler reaches working pressure, check flange assembly again for leaks.
13. Turn power on to the boiler and return to standard operation.

Insulation Resistance and Moisture Considerations

Why Insulation Resistance Can Drop

- Heating element insulation material can absorb moisture during:
- Shipping and storage
- Long shutdown periods
- High humidity environments
- Enclosures left open during installation
- This can reduce insulation resistance and lead to:
- Ground fault trips
- Nuisance lockouts
- In severe cases, dielectric breakdown at startup

When to Perform Insulation Resistance Testing

- Perform insulation resistance testing:
- Before commissioning after long storage
- After extended shutdown
- If ground fault trips occur
- If moisture intrusion is suspected

Suggested Acceptance Guidance

- Use your site standard and any Sussman Electric Boilers requirements first. If none are provided, a common approach for equipment under 1000 V is:
- Test with **500 VDC** from live circuits to ground
- Target insulation resistance per circuit should be adequately high and stable



CAUTION

If insulation resistance is low, do not continue energizing the boiler. Contact Sussman Electric Boilers or your authorized service representative for guidance. Dry out procedures, repair, or element replacement may be required.

Controls and HMI Maintenance

Display and Controller Health Checks

- Monthly or during troubleshooting:
- Verify temperature sensors display stable, believable readings.
- Verify cabinet temperature reading (if displayed) is normal.
- Confirm alarms are cleared and not repeating.
- Confirm date and time are correct.

Firmware and Configuration Updates

- Update software or firmware only when:
- Directed by Sussman Electric Boilers
- Required for multi boiler integration
- Required to resolve a documented issue
- **Best practice for multi boiler systems**
Keep all units on the same approved firmware and configuration revision to avoid communication or sequencing issues.

Communications Settings

- If the boiler is connected to BAS:
- Verify IP address settings for the BAS connected port only
- Verify BACnet device ID or Modbus addressing matches site documentation
- Record any changes in the service log



WARNING

- Do not change internal network settings or addressing without coordination with the site controls team. Incorrect settings can disable BAS communication or cause control instability.



WARNING

- Lock out and verify power is off before opening electrical enclosures.
- Lock out all power sources.
- Verify absence of voltage.

Cleaning and Inspection Procedures

Electrical Compartment Cleaning

- Use a dry method first: vacuum with ESD safe equipment if available.
- If needed, use approved electrical contact cleaner sparingly.
- Inspect for:
 - Loose conductors
 - Heat discoloration
 - Damaged insulation
 - Moisture
 - Dust accumulation around contactors and power devices
- Reassemble and ensure covers are properly seated.

Hydronic Side Inspection

- Check strainers and clean as needed.
- Inspect pumps for seal leakage and bearing noise.
- Verify expansion tank charge and operation.
- Verify air removal devices function properly.
- Review water treatment logs and sample results.

After Any Maintenance or Repair

- Confirm all covers are installed and secured.
- Remove tools and foreign material from compartments.
- Restore power per site LOTO procedure.
- Perform operational verification:
 - No active alarms
 - Correct pump operation and flow proving

- Stable temperature control
- Expected staging and kW output behavior
- Record work performed, readings, and any alarms in the service history.

Troubleshooting Guide (Maintenance Focus)

Problem	Likely Cause	What to Check
HMI dark or controls not powered	Loss of control power, blown fuses, loose wiring	Verify incoming control power, check fusing, verify terminal tightness, verify internal power supplies, inspect connectors to HMI and control modules
Nuisance high temperature limit trips	Setpoint too close to high limit, inadequate flow, air in system, sensor issue	Verify high limit setting is above operating setpoint plus control differential, verify pump operation, verify flow switch or flow meter, inspect air elimination, confirm sensor readings
Boiler short cycling	Control differential too tight, rapidly changing BAS setpoints, PID tuning, intermittent flow	Increase control differential if appropriate, ensure BAS commands change slowly, review PID settings only with qualified support, confirm stable flow and pump operation
Temperature readings erratic or incorrect	Failed sensor, loose wiring, moisture intrusion, electrical noise	Inspect sensor wiring and terminations, swap with known good sensor if permitted, ensure shield grounding practices match drawings
CPU or controller fault displayed	Module seating issue, failed module, corrupted configuration	With power off, reseat modules and connectors, review alarm journal, reload approved configuration if instructed, replace module if confirmed failed
Errors during update	Wrong update package, incorrect media, interrupted update	Use approved software revision, use properly formatted media if required, do not interrupt update, contact authorized support if mismatch persists
Communication loss to BAS	IP or address mismatch, wiring issue, network conflict	Verify port selection, IP settings, BACnet device ID or Modbus address, cabling and switch port, confirm network is active and non-conflicting
Repeated ground fault trips	Low insulation resistance due to moisture or element degradation	Perform insulation resistance test, inspect for moisture, do not keep re-energizing, contact authorized service for dry out or element replacement plan

Maintenance Records

Maintain a log that includes:

- Date and technician
- Operating readings (inlet, outlet, setpoint, cabinet temp)
- Alarms observed and cleared
- Torque checks completed and values used (with reference to drawings)
- Insulation resistance readings if performed
- Parts replaced (including gasket replacement)
- Firmware or configuration changes (version and reason)
- Accurate maintenance records help with warranty consideration and long term reliability.