

ST SERIES

SEMI-INSTANTANEOUS WATER HEATERS

FEATURES:

- Steam-to Water and Water-to-Water configurations.
- Available in single and double wall construction.
- Copper (standard) and optional CuNi or SS bundle material of construction.
- Copper, Cu-Ni or SS material in contact with water (potable water).
- Fully packaged solution for quick and easy single point connections.
- Available in vertical or horizontal (optional) construction.
- Compact foot print- Fits through a standard doorway.
- Standard trim is available up to 200 psi and optional up to 250 psi.
- Fully modulating energy input for precise temperature controls.
- Available in electronic or pneumatic controls.
- NEW Advanced Electronic PID controls with touchscreen user interface and compatible with Building Management System via ModBus IP or built-in BacNet IP.
- Domestic Water Pressure Drop: Less than 5 PSI.
- Low Lead Complaint.
- Made in America.
- ASME- B&PV Code Sec. VIII, Div. 1 Stamped.
- Warranty: Tube Bundle (5) years, Shell (10) years.

The Diversified Heat Transfer (DHT) ST Series of Semi-Instantaneous Water Heaters are the engineered solution for facility managers, mechanical contractors, and engineers who need high recovery capacity in a small space. They are constructed with a stainless steel shell and other non-ferrous materials to ensure long leak-free operation. Designed for continuous high-peak loads, the DHT ST Series is ideal for high-demand applications, such as hospitals and dormitories.

Units are custom engineered using steam or boiler water as the heating medium. Semi-instantaneous operation provides high output by channeling the incoming cold water directly over the heat exchanger tubes in a controlled manner to maximize the heat transfer rates compared to conventional stratified heat exchanger convection systems. Velocity of water and pressure drop are controlled by changing water flow directly across the heat exchanger, which increases heat transfer and inhibits scale formation.

Perfect for mechanical rooms where space is limited, the water heating systems feature vertical configurations so they require less than four square feet of floor space. Plus, the tube bundle can be removed straight out or downward from the bottom of the unit to eliminate the need for overhead space or extra clearances for service or maintenance.



APPLICATIONS:

- Ideal for new or retrofit installations
- Suitable for both single or multiple unit installations
- No storage tanks required for instantaneous applications
- Support variety of applications including:
 - Apartment Complexes
 - Prisons / Correctional Facilities
 - Hospitals/ Nursing homes/ Medical Centers
 - Hotels/ Entertainment Facilities
 - Schools/ Colleges/ Universities/ Dormitories
 - Commercial laundries
 - Government & Office buildings
 - Industrial applications

VERTICAL UNIT DIMENSIONS:

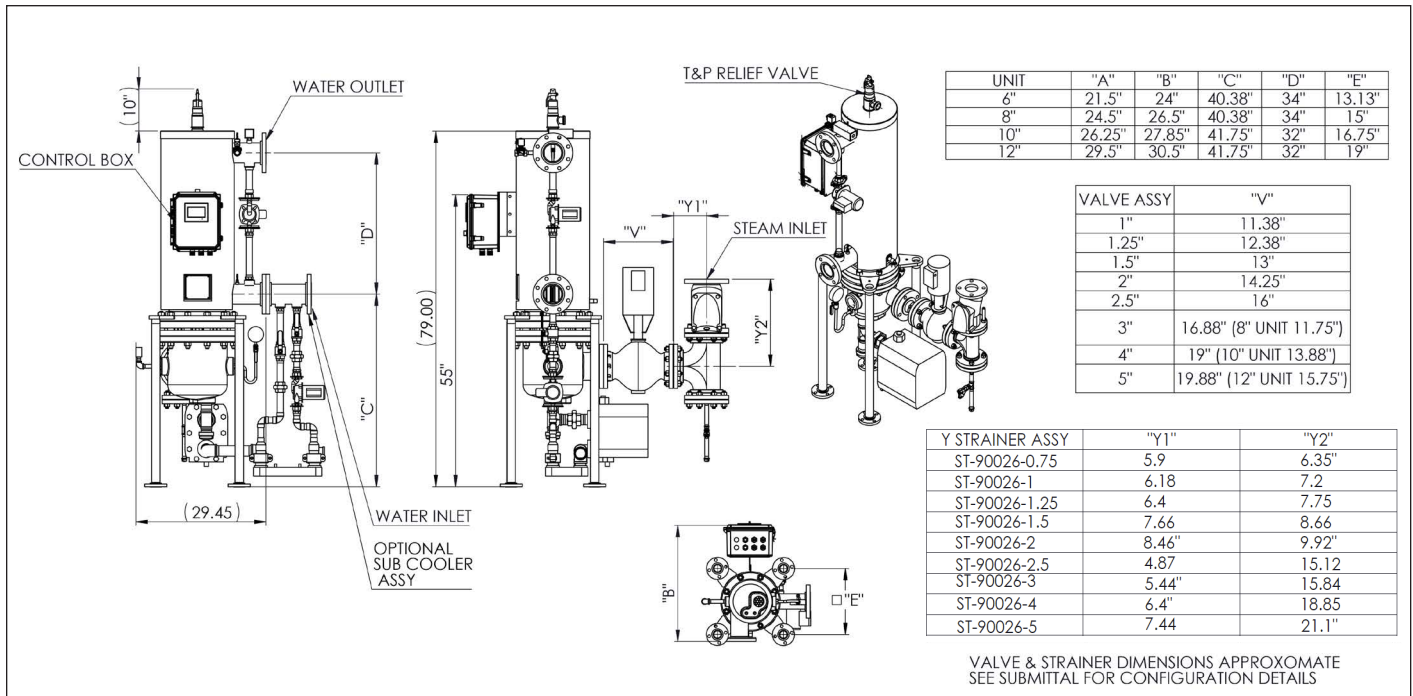

HORIZONTAL UNIT DIMENSIONS:

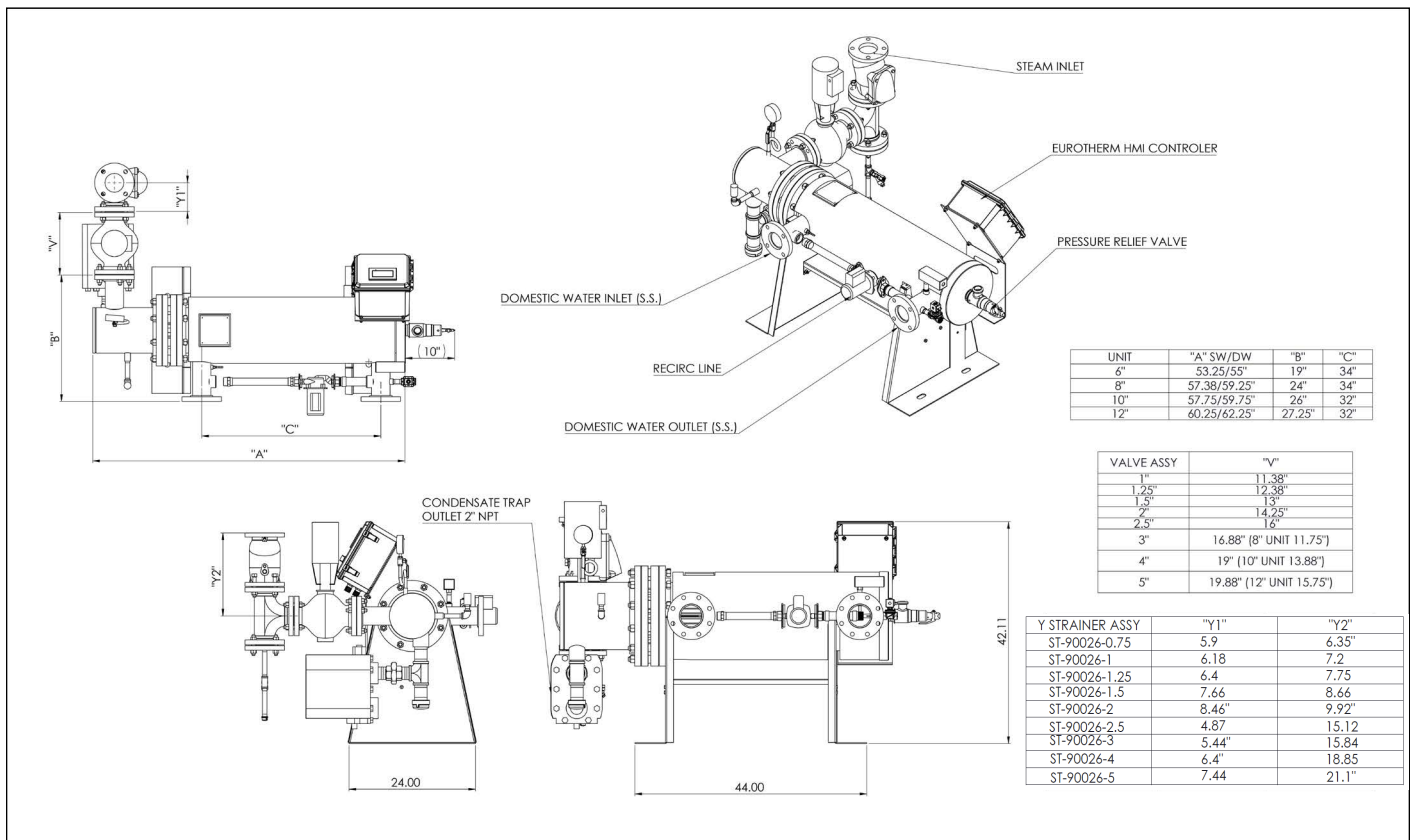

Note: Refer to dimensional drawing on www.dhtnet.com for latest updates.

UNIT SPECIFICATIONS:

Unit (Shell) Size	6"	8"	10"	12"
Ambient Temperature, °F	32-120			
Electrical Requirements	110V/1Ph/60Hz 6 Amps			
Standby Amperage Draw, Amps	2.0			
Max. Instantaneous Water Flow Rate, GPM	90	125	225	225
Max. Steam Supply Pressure, PSIG	150 psi to the valve			
Max. Shell Side Operating Pressure, PSIG	200 (250 psi optional)			
Adjustable Temperature Control, °F	35-180			
Adjustable High Limit Control, °F	100-240			
Accuracy, °F	+/-4			
Water Inlet & Outlet Connection	2.50" Flange	3.00" Flange	4.00" Flange	4.00" Flange
Single Wall Unit- Est. Shipping Weight, LBS	875	1325	1475	1650
Double Wall Unit- Est. Shipping Weight, LBS	950	1400	1550	1750
Double Wall Unit- Available Tube Diameters	3/4" (Standard)		5/8" (High Output)	
Standard Listing & Approvals	ASME B&PV code Sec. VIII, Div. 1 Stamped			

WATER HEATER CONTROLLER:

FEATURES:

- 4.3 HMI Touchscreen
- Feedforward Logic Controller includes 1/8 DIN with LCD display (back-up interface)
- Data Logging
- Fault Log
- Trending/Graphing
- Compatibility with Modbus IP and BacNet IP BAS system standard without the need for external gateway.
- A gateway can be used for all other protocols



The NEW DHT state of the art control system offers unmatched performance and full user configurable for water heater applications. It features a durable temperature sensor transmitting a millivolt signal through quality twisted shielded wiring. The signal transmits directly into the advanced PID controller, which in turn sends a signal to the electrically activated fully modulating and fast acting control valve to achieve accurate temperature control over various demand situations. The controller has a 4.3-inch TFT color touchscreen user interface and is compatible with a Building Management System via ModBus IP or built-in BacNet IP. Optional communications gateway is also available for RS485 communication.

Enclosure Dimensions	12"H x 10" W x 7" D
Display	4.3" TFT Color LCD
Graphics Display Resolution/ Colors	480 x 272 pixels w/ 65,536 display colors
Backlight	White LED, service life 50,000 hours and 24hr operation
Brightness control	16 Levels (Adjusted with touch panel)
Operating Mode	Single Tone, Visual Indicator
Memory	8Gb
Supply Voltage	120/240 VAC
Certifications	NEMA 4, UL

DHT SUB-COOLING HEAT EXCHANGER OPTION:

A condensate receiver is required in a steam distribution system that is vented to the atmosphere. As a result, flash steam is generated, evacuated through the vent, and a considerable amount of energy is lost. Roughly 11% of the condensate is lost and must be replaced by new water feed to the system. Feeding more water requires more heat energy and additional water treatment increasing the total operating cost for the system.

ST Series steam to water units are available with optional condensate sub-cooling kit which includes piping assembly with circulator and a compact brazed plate sub-cooling heat exchanger which cools down the condensate to safe drain temperatures by recovering waste heat from it. This recovered waste heat energy is used in pre-heating the cold water entering the unit.

Condensate sub-cooling increases the overall system efficiency above 90% which require less steam consumption as compared to standard unit.

- Available in single and double wall construction
- Reduce flash losses in the system
- Reduced Operating Costs- Increase system efficiency up to 14%
- Dilution tank or flash tank not required with ST Series sub-cooling option.

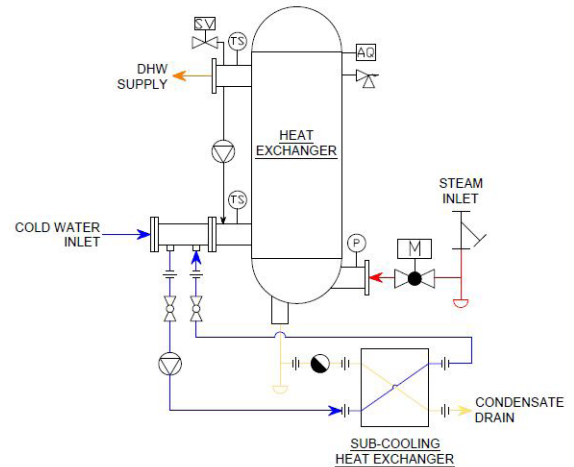
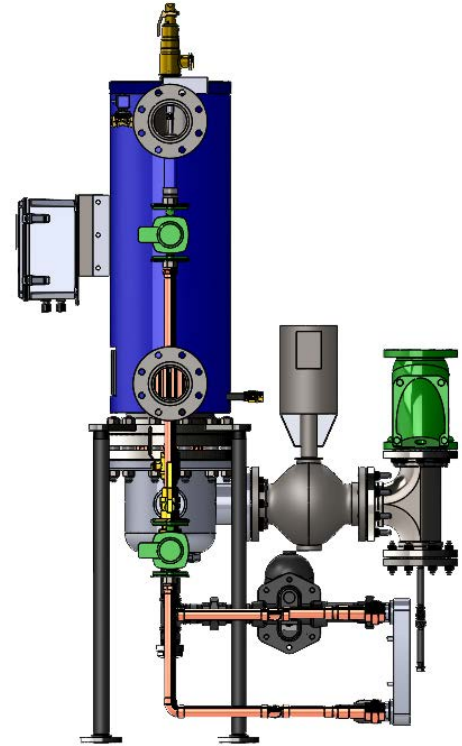

DHT can accept no responsibility for possible errors in catalogs, brochures, and other printed material. DHT reserves the right to alter its products without notice. DHT and the DHT logotype are trademarks of DHT. All rights reserved.